



LM Guide Actuator

THK General Catalog

LM Guide Actuator

THK General Catalog

A Product Descriptions

Caged Ball LM Guide Actuator Model SKR .. A2-4

- Structure and Features A2-4
- Caged Ball Technology A2-6
- Types and Features A2-9
- Load Ratings in All Directions and Static Permissible Moment .. A2-10
- Maximum Speeds with Different Strokes .. A2-16
- Lubrication A2-18
- Static Safety Factor A2-19
- Service Life A2-20
- Accuracy Standards A2-23
- Model Number Coding A2-28

Dimensional Drawing, Dimensional Table

- Model SKR20 Standard Type A2-30
- Model SKR20 (with a Cover) A2-31
- Model SKR26 Standard Type A2-32
- Model SKR26 (with a Cover) A2-33
- Model SKR33 Standard Type A2-34
- Model SKR33 (with a Cover) A2-35
- Model SKR33 Standard Type A2-36
- Model SKR33 (with a Cover) A2-37
- Model SKR46 Standard Type A2-38
- Model SKR46 (with a Cover) A2-39
- Model SKR46 Standard Type A2-40
- Model SKR46 (with a Cover) A2-41
- Model SKR55 Standard Type A2-42
- Model SKR55 (with a Cover) A2-43
- Model SKR65 Standard Type A2-44
- Model SKR65 (with a Cover) A2-45
- Mass of Moving Element A2-46

Options A2-47

- Bellows A2-47
- Sensor A2-52
- Housing A2-56
- Intermediate Flange A2-57
- Motor Wrap Type A2-72

LM Guide Actuator Model KR A2-74

- Structure and Features A2-74
- Types and Features A2-78
- Load Ratings in All Directions and Static Permissible Moment .. A2-79
- Maximum Speeds with Different Strokes .. A2-84
- Lubrication A2-86
- Static Safety Factor A2-87
- Service Life A2-88
- Accuracy Standards A2-91
- Model Number Coding A2-96

Dimensional Drawing, Dimensional Table

- Model KR15 Standard Type A2-98
- Model KR15 (with a Cover) A2-99
- Model KR20 Standard Type A2-100
- Model KR20 (with a Cover) A2-101
- Model KR26 Standard Type A2-102
- Model KR26 (with a Cover) A2-103
- Model KR30H Standard Type A2-104
- Model KR30H (with a Cover) A2-105
- Model KR30H Standard Type A2-106
- Model KR30H (with a Cover) A2-107
- Model KR33 Standard Type A2-108
- Model KR33 (with a Cover) A2-109
- Model KR33 Standard Type A2-110
- Model KR33 (with a Cover) A2-111
- Model KR45H Standard Type A2-112
- Model KR45H (with a Cover) A2-113
- Model KR45H Standard Type A2-114
- Model KR45H (with a Cover) A2-115
- Model KR46 Standard Type A2-116
- Model KR46 (with a Cover) A2-117
- Model KR46 Standard Type A2-118
- Model KR46 (with a Cover) A2-119
- Model KR55 Standard Type A2-120
- Model KR55 (with a Cover) A2-121
- Model KR65 Standard Type A2-122
- Model KR65 (with a Cover) A2-123
- Mass of Moving Element A2-124

Options A2-125

- Bellows A2-125
- Sensor A2-131
- Housing A2-135
- Intermediate Flange A2-136
- Motor Wrap Type A2-160
- XY Bracket (for Reference) A2-161

Model No. A2-164

Precautions on Use A2-166

B Support Book (Separate)

Features	B2-4
Features of the LM Guide Actuator.....	B2-4
• Structure and Features	B2-4
• Caged Ball Technology (SKR).....	B2-6
Point of Selection	B2-7
Static Safety Factor	B2-7
Service Life.....	B2-8
Example of Calculating the Nominal Life ..	B2-11
Options	B2-20
Cover	B2-21
Bellows	B2-21
Sensor	B2-22
Housing	B2-22
Motor Wrap Type	B2-23
XY Bracket (for Reference)	B2-23
Model No.	B2-24
Precautions on Use	B2-26

SKR



Caged Ball LM Guide Actuator Model SKR

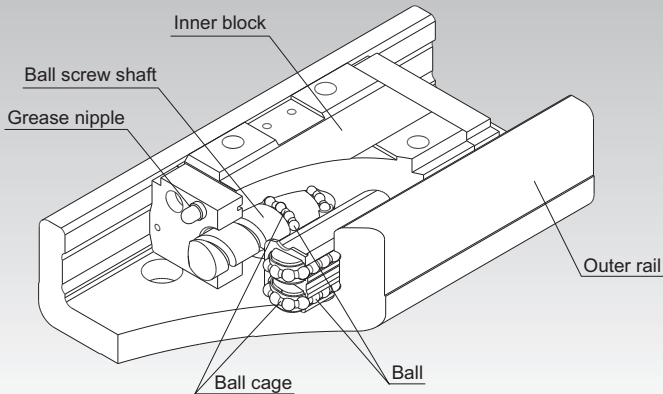

Fig.1 Structure of Caged Ball LM Guide Actuator Model SKR

Structure and Features

Caged Ball LM Guide Actuator model SKR is a compact actuator that has a inner block consisting of LM blocks and a ball screw nut integrated inside a U-shaped outer rail.

In addition, this model achieves high speed operation, lower noise and longer-term maintenance-free operation by using ball cages in the LM Guide units and the Ball Screw unit. (A ball cage is used only for the LM guide section of models SKR20 and SKR26 and the ball screws are fitted with QZ lubricators.)

[4-way Equal Load]

Each row of balls is arranged at a contact angle of 45° so that the rated load on the inner block is uniform under loads applied to the inner block in the four directions (radial, reverse radial and lateral directions). As a result, model SKR can be used in any mounting orientation.

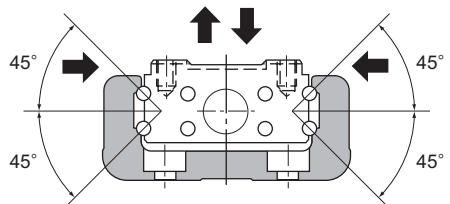

Fig.2 Load Capacity and Contact Angle of Model SKR

[High Rigidity]

Use of an outer rail with a U-shaped cross section increases the rigidity with respect to moment and torsion.

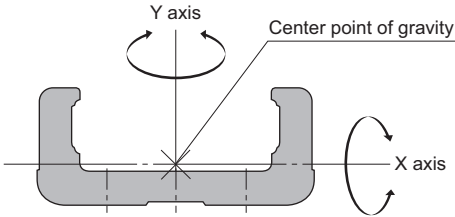

Fig.3 Cross Section of the Outer Rail

Table1 Cross-sectional Characteristics of the Outer rail Rail

Model No.	I_x [mm ⁴]	I_y [mm ⁴]	Mass[kg/m]
SKR20	6.0×10^3	6.14×10^4	2.6
SKR26	1.66×10^4	1.48×10^5	3.9
SKR33	5.35×10^4	3.52×10^5	6.1
SKR46	2.05×10^5	1.45×10^6	12.6
SKR55	2.07×10^5	2.09×10^6	13.2
SKR65	4.51×10^5	5.73×10^6	22.1

I_x =geometrical moment of inertia around X axis
 I_y =geometrical moment of inertia around Y axis

[High Accuracy]

Since the linear guide section consists of 4 rows of circular-arc grooves that enable balls to smoothly move even under a preload, a highly rigid guide with no clearance is achieved. Additionally, variation in frictional resistance caused by load fluctuation is minimized, allowing the system to follow highly accurate feed.

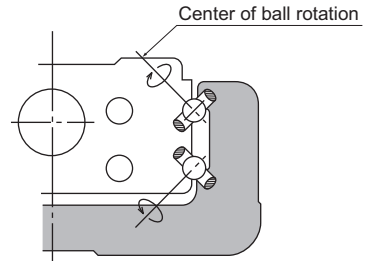

Fig.4 Contact Structure of SKR

[Space Saving]

Due to an integral structure where LM Guide units are placed on both side faces of the inner block and a Ball Screw unit is placed in the center of the inner block, a highly rigid and highly accurate actuator with a minimal space is achieved.

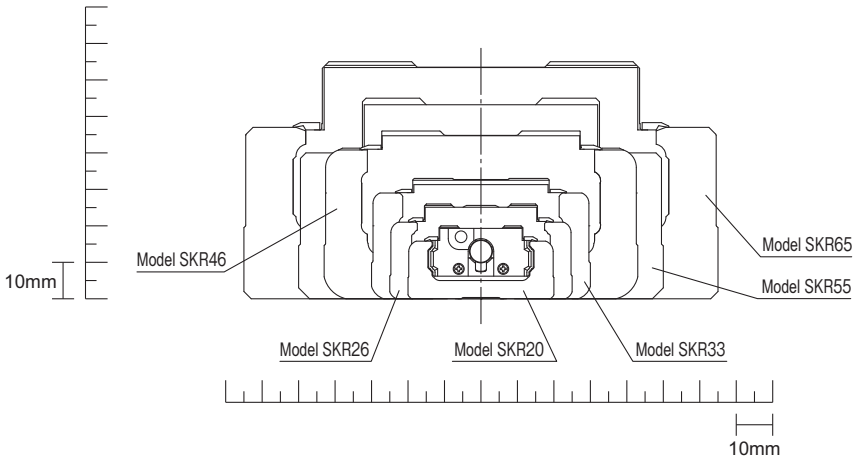

Fig.5 Cross Sectional Drawing

Caged Ball Technology

[High Speed]

Model SKR supports a latest high-rotation servomotor ($6,000 \text{ min}^{-1}$) by using a ball cage and is capable of operating at higher speed than the full-ball type model KR.

Models SKR33/55/65 are available in more leads variations to achieve higher speed operation and high leads are available which was not feasible with the model KR.

Model No.	Lead	
	SKR	KR
33	6, 10, 20	6, 10
55	20, 30, 40	20
65	20, 25, 30, 50	25

[High Lubricity]

Model SKR uses ball cages to eliminate friction between balls and significantly improve torque characteristics. As a result, the torque fluctuation is reduced and superb lubricity is achieved.

Item	Description
Shaft diameter/lead	$\phi 13/10\text{mm}$
Shaft rotation speed	60min^{-1}

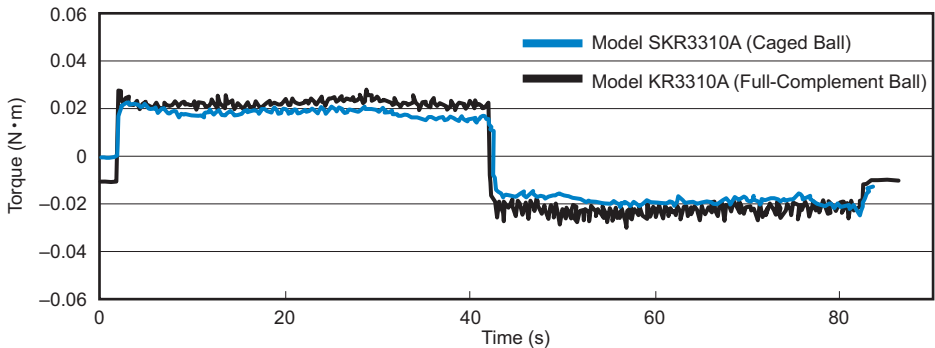

Fig.6 Comparison of Torque Fluctuation between Model SKR and Model KR

[Low Noise, Acceptable Running Sound]

In model SKR, the use of a ball cage in the LM Guide section and Ball Screw section (excluding models SKR20/26) has eliminated collision noise between the balls. As a result, low noise and acceptable running sound are achieved.

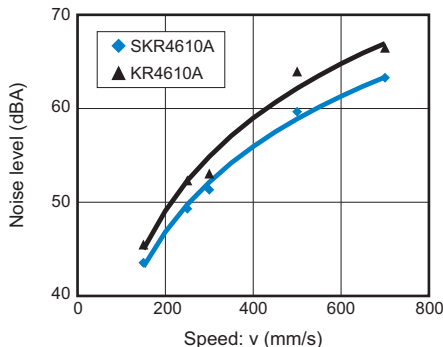

Fig.7 Comparison of Noise between Model SKR4610A and Model KR4610A

[Long-term Maintenance-free Operation]

With model SKR, the ball cage effect helps increase grease retention and achieve long-term maintenance-free operation.

[Long service life—3 times]

With model SKR, both the LM Guide unit and the Ball Screw unit have larger basic dynamic load ratings than the full-ball type model KR, and therefore a longer service lives are achieved.

The rated service life is calculated from the following equation.

LM guide unit

$$L = (C/P)^3 \times 50$$

L : Nominal life

C : Basic dynamic load rating (N)

P : Applied load (N)

Ball screw unit

$$L = (Ca/Fa)^3 \times 10^6$$

L : Nominal life (rev)

Ca : Basic dynamic load rating (N)

Fa : Applied axial load (N)

As indicated in the equation above, the greater the basic dynamic load rating, the longer the service life of both the LM Guide unit and the Ball Screw unit.

Table2 Comparison of Basic Dynamic Load Rating between Model SKR and Model KR

Unit: N

Basic dynamic load rating		SKR 20	KR 20	SKR 26	KR 26	SKR 33	KR 33	SKR 46	KR 46	SKR 55	KR 55	SKR 65	KR 65
LM guide unit C	Long type block	6010	3590	13000	7240	17000	11600	39500	27400	55400	38100	74400	50900
	Short type block	—	—	—	—	11300	4900	28400	14000	—	—	—	—
Ball screw unit Ca		660	660	2350	2350	2700	1760	4240	3040	10900	3620	12000	5680

Note) On the SKR20/26, only the LM guide section features a ball cage.

[Seal]

Model SKR is equipped with end seals and side seals for dust prevention as standard.

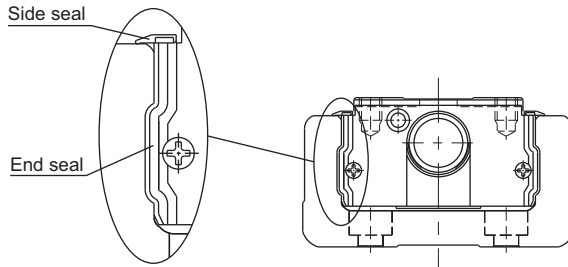

Table3 shows the rolling resistance and seal resistance per inner block (guide section).

Table3 Maximum Resistance Value Unit: N

Model No.	Rolling resistance value	Seal resistance value	Total
SKR20	4.0	0.8	4.8
SKR26	4.5	1.2	5.7
SKR33	3.0	1.7	4.7
SKR46	6.0	2.1	8.1
SKR55	14.0	3.8	17.8
SKR65	20.0	4.1	24.1

Types and Features

Model SKR-A (with a Single Long Type Block)

Representative model of SKR.

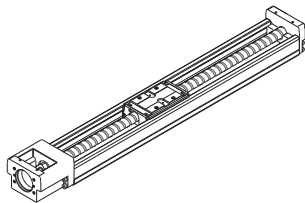

Model SKR-A

Model SKR-B (with Two Long Type Blocks)

Equipped with two units of the inner block of model SKR-A, this model achieves higher rigidity and higher load carrying capacity.

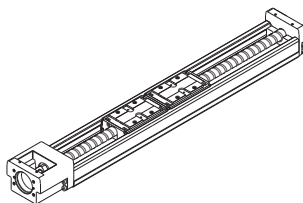

Model SKR-B

Model SKR-C (with a Single Short Type Block)

This model has a shorter overall length of the inner block and a longer stroke than model SKR-A.

* With model SKR3320, a short-block type is not available.

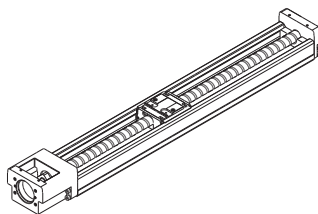

Model SKR-C

Model SKR-D (with Two Short Type Blocks)

Equipped with two units of the inner block of model SKR-C, this design allows a span between blocks that suits the equipment, thus to achieve high rigidity.

* With model SKR3320, a short-block type is not available.

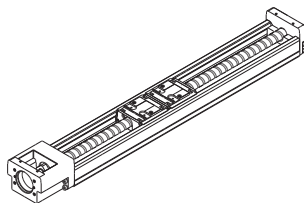

Model SKR-D

Load Ratings in All Directions and Static Permissible Moment

[Load Rating]

Caged Ball LM Guide Actuator Model SKR consists of an LM Guide, a Ball Screw and a support bearing.

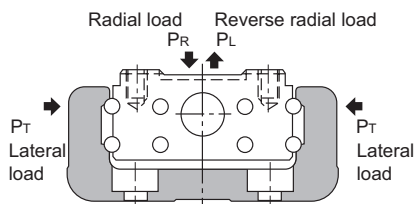

● LM Guide Unit

Model SKR is capable of receiving loads in four directions (radial, reverse radial and lateral directions). Its basic load ratings are equal in all four directions (radial, reverse radial and lateral directions), and their values are indicated in Table4.

● Ball Screw Unit

Since the inner block is incorporated with a ball screw nut, model SKR is capable of receiving an axial load. The basic load rating value is indicated in Table4.

● Bearing Unit (Fixed Side)

Since housing A contains an angular bearing, model SKR is capable of receiving an axial load. The basic load rating value is indicated in Table4.

[Equivalent Load (LM Guide Unit)]

The equivalent load when the LM Guide unit of model SKR simultaneously receives loads in all directions is obtained from the following equation.

$$P_E = P_R (P_L) + P_T$$

P_E	: Equivalent load	(N)
	: Radial direction	
	: Reverse radial direction	
	: Lateral directions	
P_R	: Radial load	(N)
P_L	: Reverse radial load	(N)
P_T	: Lateral load	(N)

Table4 Load Rating of Model SKR

Model No.			SKR20		SKR26		SKR33*		
			SKR2001	SKR2006	SKR2602	SKR2606	SKR3306	SKR3310	SKR3320
LM guide unit	Basic dynamic load rating C (N)	Long type block	6010		13000		17000		
		Short type block	—		—		11300	—	
	Basic static load rating C ₀ (N)	Long type block	8030		16500		20400		
		Short type block	—		—		11500	—	
	Radial clearance (mm)	Normal grade, high accuracy grade	-0.004 to 0		-0.006 to 0		-0.004 to 0		
		Precision grade	-0.006 to -0.004		-0.007 to -0.006		-0.012 to -0.004		
Ball screw unit	Basic dynamic load rating C _a (N)	Normal grade, high accuracy grade	660	860	2350	1950	4400	2700	2620
		Precision grade	660	1060	2350	2390			
	Basic static load rating C _{0a} (N)	Normal grade, high accuracy grade	1170	1450	4020	3510	6290	3780	3770
		Precision grade	1170	1600	4020	3900			
	Screw shaft diameter (mm)		6		8		13		
	Ball Screw lead (mm)		1	6	2	6	6	10	20
	Thread minor diameter (mm)		5.3	5.0	6.6	6.7	10.8		
	Ball center-to-center diameter (mm)		6.15	6.3	8.3	8.4	13.5		
Bearing unit (Fixed side)	Axial direction	Basic dynamic load rating C _a (N)	1150		2000		6250		
		Static permissible load P _{0a} (N)	735		1230		2700		

*For use in a special environment or where an axial load (25% or more of the basic dynamic load rating C_a) is applied, a special type is also available. Contact THK for details.

Note1) The load ratings in the LM Guide unit each indicate the load rating per inner block.

Note2) With model SKR3320, a short-block type is not available.

SKR46*		SKR55			SKR65			
SKR4610	SKR4620	SKR5520	SKR5530	SKR5540	SKR6520	SKR6525	SKR6530	SKR6550
39500		55400			74400			
28400		—			—			
45900		62500			81600			
28700		—			—			
-0.006 to 0		-0.007 to 0			-0.008 to 0			
-0.016 to -0.006		-0.019 to -0.007			-0.022 to -0.008			
4350	4240	10900	7000	6800	12100	12000	8200	7600
6990	7040	17600	11500	9900	21600	22000	14500	12600
15		20			25			
10	20	20	30	40	20	25	30	50
12.5		17.1			22.1			
15.75		20.75			25.75			
6700		7600			13700			
3330		3990			5830			

[Permissible Moment (LM Guide Unit)]

The Inner block is capable of receiving moment loads in all three (3) directions.

A2-15 Table 5 shows the permissible static moment in the M_A , M_B and M_C directions.

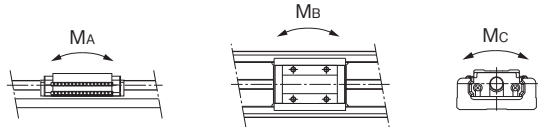
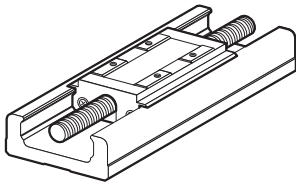

With a single long type block (Model SKR-A)

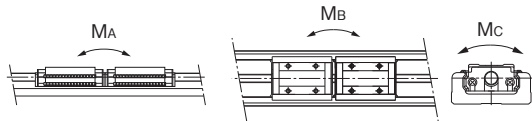
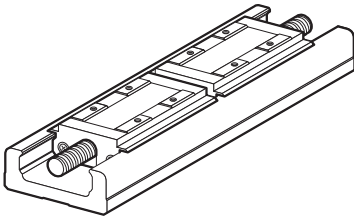

With double long type blocks (Model SKR-B)

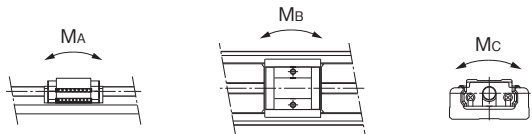
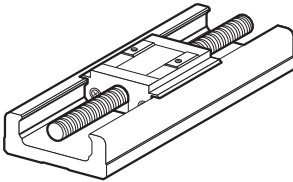

With a single short type block (Model SKR-C)

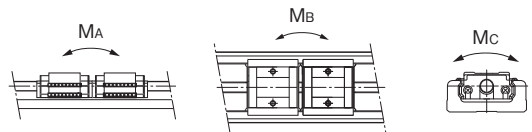
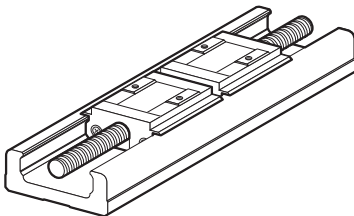

With double short type blocks (Model SKR-D)

Table5 Static Permissible Moments of Model SKR

Unit: N-m

Model No.	Static permissible moment		
	M _A	M _B	M _C
SKR20-A	38	38	98
SKR20-B	207	207	197
SKR26-A	117	117	265
SKR26-B	589	589	530
SKR33-A	173	173	424
SKR33-B	990	990	848
SKR33-C	58	58	240
SKR33-D	390	390	480
SKR46-A	579	579	1390
SKR46-B	3240	3240	2780
SKR46-C	236	236	870
SKR46-D	1460	1460	1740
SKR55-A	923	923	2276
SKR55-B	5125	5125	4552
SKR65-A	1366	1366	3868
SKR65-B	7702	7702	7736

Note1) Symbols A, B, C or D in the end of each model number indicates the inner block size and the number of inner blocks used.

A: With a single long type block

B: With double long type blocks

C: With a single short type block

D: With double short type blocks

Note2) The values for models SKR-B/D indicate the values when double inner blocks are used in close contact with each other.

Note3) Static permissible moment is the maximum moment that can be permitted while the product is stationary.

Maximum Speeds with Different Strokes

Table6 Maximum speed

Model No.	Ball Screw lead (mm)	Stroke* (mm)		Outer rail length (mm)	Maximum speed (mm/s)		
		Long type block	Short type block		Long type block	Short type block	
SKR20	1	30	—	100	100	—	
		80	—	150	100	—	
		130	—	200	100	—	
	6	30	—	100	600	—	
		80	—	150	600	—	
		130	—	200	600	—	
SKR26	2	60	—	150	200	—	
		110	—	200	200	—	
		160	—	250	200	—	
		210	—	300	200	—	
	6	60	—	150	600	—	
		110	—	200	600	—	
		160	—	250	600	—	
		210	—	300	600	—	
		—	—	—	—	—	
SKR33	6	45	70	150	600	600	
		95	120	200	600	600	
		195	220	300	600	600	
		295	320	400	600	600	
		395	420	500	600	600	
		495	520	600	550	500	
		595	620	700	390	360	
	10	45	70	150	1000	1000	
		95	120	200	1000	1000	
		195	220	300	1000	1000	
		295	320	400	1000	1000	
		395	420	500	1000	1000	
		495	520	600	920	830	
		595	620	700	650	600	
	20	45	—	150	2000	—	
		95	—	200	2000	—	
		195	—	300	2000	—	
		295	—	400	2000	—	
		395	—	500	2000	—	
		495	—	600	1780	—	
		595	—	700	1270	—	
	SKR46	10	190	220	340	1000	1000
			290	320	440	1000	1000
			390	420	540	1000	1000
490			520	640	1000	910	
590			620	740	730	660	
690			720	840	550	500	
790			820	940	430	400	
20		190	220	340	2000	2000	
		290	320	440	2000	2000	
		390	420	540	2000	2000	
		490	520	640	1980	1770	
		590	620	740	1430	1300	
		690	720	840	1080	990	
		790	820	940	840	780	

*Indicates a stroke when one inner block is incorporated.

Note1) The maximum speed is the value restricted by the permissible rotation speed of the Ball Screw or the permissible speed of the guide, with the motor rotating at 6,000 min⁻¹.

Note2) When considering the use of this model at speed higher than the maximum speed indicated above, contact THK.

Model No.	Ball Screw lead (mm)	Stroke* (mm)		Outer rail length (mm)	Maximum speed (mm/s)	
		Long type block	Short type block		Long type block	Short type block
SKR55	20	800	—	980	1100	—
		900		1080	880	
		1000		1180	730	
		1100		1280	610	
		1200		1380	520	
	30	800		980	1650	
		900		1080	1330	
		1000		1180	1100	
		1100		1280	920	
		1200		1380	780	
	40	800		980	2160	
		900		1080	1750	
		1000		1180	1440	
		1100		1280	1210	
		1200		1380	1030	
SKR65	20	790	980	1470	—	
		990	1180	970		
		1190	1380	690		
		1490	1680	450		
	25	790	980	1810		
		990	1180	1200		
		1190	1380	850		
		1490	1680	550		
	30	790	980	2210		
		990	1180	1460		
		1190	1380	1030		
		1490	1680	670		
	50	790	980	3000		
		990	1180	2350		
		1190	1380	1680		
1490		1680	1100			

*Indicates a stroke when one inner block is incorporated.

Note1) The maximum speed is restricted by the permissible rotation speed of the ball screw, the permissible speed of the guide or 6,000 min⁻¹ of motor speed.

Note2) When considering the use of this model at speed higher than the maximum speed indicated above, contact THK.

Lubrication

Table7 shows standard greases used in model SKR and grease nipple types.

Table7 Types of standard grease and grease nipples used

Model No.	Standard grease	Grease nipple used
SKR20	THK AFA Grease	PB107
SKR26	THK AFA Grease	PB107
SKR33	THK AFB-LF Grease	PB107
SKR46	THK AFB-LF Grease	A-M6F
SKR55	THK AFB-LF Grease	A-M6F
SKR65	THK AFB-LF Grease	A-M6F

Static Safety Factor

Caged Ball LM Guide Actuator Model SKR consists of an LM Guide, a Ball Screw and a support bearing. The static safety factor and the service life of each component can be obtained from the basic load rating indicated in "Rated load of model SKR" (see Table 4-12).

[Calculating the Static Safety Factor]

● LM Guide Unit

To calculate a load applied to the LM Guide of model SKR, the average load required for calculating the service life and the maximum load needed for calculating the static safety factor must be obtained first. In particular, if the system starts and stops frequently, or if a large moment caused by an overhung load is applied to the system, it may receive an unexpectedly large load.

When selecting a model number, make sure that the desired model is capable of receiving the required maximum load (whether stationary or in motion).

$$f_s = \frac{C_0}{P_{\max}}$$

f_s : Static safety factor

C_0 : Basic static load rating (N)

P_{\max} : Maximum applied load (N)

*The basic static load rating is a static load with a constant direction and magnitude whereby the sum of the permanent deformation of the rolling element and that of the raceway on the contact area under the maximum stress is 0.0001 times the rolling element diameter.

● Ball Screw Unit/Bearing Unit(Fixed Side)

If an unexpected external force is applied in the axial direction as a result of an inertia caused by an impact or start and stop while model SKR is stationary or operating, it is necessary to take into account the static safety factor.

$$f_s = \frac{C_{0a}}{F_{\max}}$$

f_s : Static safety factor

C_{0a} : Basic static load rating (N)

F_{\max} : Maximum applied load (N)

[Standard Values for the Static Safety Factor (f_s)]

Machine type	Load conditions	Minimum Static Safety Factor (f_s)
General industrial machinery	Without vibration or impact	1.0 to 3.5
	With vibration or impact	2.0 to 5.0

*The standard value of the static safety factor may vary depending on the load conditions as well as environment, lubrication status, mounting accuracy, and/or rigidity.

Service Life

[LM Guide Unit]

● Nominal Life

The nominal life (L) means the total travel distance that 90% of a group of units of the same LM Guide model can achieve without flaking (scale-like pieces on the metal surface) after individually running under the same conditions.

The nominal life of the LM Guide is obtained using the following equation.

$$L = \left(\frac{f_c \cdot C}{f_w \cdot P_c} \right)^3 \times 50$$

L : Nominal life (km) f_w : Load factor (see Table8 on **A2-21**)
 C : Basic dynamic load rating (N) f_c : Contact factor (see Table9 on **A2-22**)
 P_c : Calculated applied load (N)

- If a moment is applied, calculate the equivalent load by multiplying the applied moment by the equivalent factor indicated in Table10 on **A2-22**.

$$P_m = K \cdot M$$

P_m : Equivalent load (per inner block) (N)

K : Equivalent moment factor

M : Applied moment (N-mm)

(If planning to use the product with a wide inner block span, contact THK.)

If moment M_c is applied to model SKR-B/D

$$P_m = \frac{K_c \cdot M_c}{2}$$

- If a radial load (P) and a moment are simultaneously applied to model SKR

$$P_E = P_m + P$$

P_E : Overall equivalent radial load (N)

Perform a nominal life calculation using the above data.

● Service Life Time

When the nominal life (L) has been obtained, the service life time is obtained using the following equation (if the stroke length and the number of reciprocations per minute are constant).

$$L_h = \frac{L \times 10^6}{2 \cdot \ell_s \cdot n_1 \times 60}$$

L_h : Service life time (h)

ℓ_s : Stroke length (mm)

n_1 : Number of reciprocations per minute (min^{-1})

[Ball Screw Unit/Bearing Unit(Fixed Side)]

● Nominal Life

The nominal life (L) means the total travel distance that 90% of a group of units of the same Ball Screw (bearing) can achieve without flaking after individually running under the same conditions.

The nominal life of the Ball Screw unit/bearing unit (fixed side) is obtained using the following equation.

Table8 Load Factor (f_w)

$$L = \left(\frac{C_a}{f_w \cdot F_a} \right)^3 \times 10^6$$

- L : Nominal life (rev)
 C_a : Basic dynamic load rating (N)
 F_a : Axial load (N)
 f_w : Load factor (see Table8)

Vibrations/impact	Speed(V)	f _w
Faint	Very low V ≤ 0.25m/s	1 to 1.2
Weak	Slow 0.25m/s < V ≤ 1m/s	1.2 to 1.5
Medium	Medium 1m/s < V ≤ 2m/s	1.5 to 2
Strong	High V > 2m/s	2 to 3.5

● Service Life Time

When the nominal life (L) has been obtained, the service life time is obtained using the following equation (if the stroke length and the number of reciprocations per minute are constant).

$$L_h = \frac{L \cdot \ell}{2 \cdot \ell_s \cdot n_1 \times 60}$$

L_h : Service life time (h)

ℓ_s : Stroke length (mm)

(h)

(mm)

n_1 : Number of reciprocations per minute (min⁻¹)

ℓ : Ball Screw lead (mm)

■f_c: Contact Factor

If two inner blocks are used in close contact with each other with model SKR-B/D, multiply the basic load rating by the corresponding contact factor indicated in Table9.

Table9 Contact Factor (f_c)

Block type	Contact factor f _c
Model SKR-B Model SKR-D	0.81

■f_w: Load Factor

In general, machines in reciprocal motion are likely to cause vibration and impact during operation, and it is particularly difficult to accurately determine each of vibration generated during high-speed operation, impact applied during repeated starting and stopping in normal use, etc. Therefore, where the effect of speed vibration is estimated to be significant, divide the basic load rating (C) by an empirically obtained load factor.

■K: Moment Equivalent Factor (LM Guide Unit)

When model SKR travels under a moment, the distribution of load applied to the LM Guide is locally large. In such cases, calculate the load by multiplying the moment value by the corresponding moment equivalent factor indicated in Table10.

Symbols K_A, K_B and K_C indicate the moment equivalent loads in the M_A, M_B and M_C directions, respectively.

Table10 Equivalent moment factor(K)

Model No.	K _A	K _B	K _C
SKR20-A	2.34 × 10 ⁻¹	2.34 × 10 ⁻¹	8.07 × 10 ⁻²
SKR20-B	4.38 × 10 ⁻²	4.38 × 10 ⁻²	8.07 × 10 ⁻²
SKR26-A	1.59 × 10 ⁻¹	1.59 × 10 ⁻¹	6.17 × 10 ⁻²
SKR26-B	3.18 × 10 ⁻²	3.18 × 10 ⁻²	6.17 × 10 ⁻²
SKR33-A	1.42 × 10 ⁻¹	1.42 × 10 ⁻¹	5.05 × 10 ⁻²
SKR33-B	2.47 × 10 ⁻²	2.47 × 10 ⁻²	5.05 × 10 ⁻²
SKR33-C	2.39 × 10 ⁻¹	2.39 × 10 ⁻¹	5.05 × 10 ⁻²
SKR33-D	3.54 × 10 ⁻²	3.54 × 10 ⁻²	5.05 × 10 ⁻²
SKR46-A	9.51 × 10 ⁻²	9.51 × 10 ⁻²	3.46 × 10 ⁻²
SKR46-B	1.70 × 10 ⁻²	1.70 × 10 ⁻²	3.46 × 10 ⁻²
SKR46-C	1.46 × 10 ⁻¹	1.46 × 10 ⁻¹	3.46 × 10 ⁻²
SKR46-D	2.36 × 10 ⁻²	2.36 × 10 ⁻²	3.46 × 10 ⁻²
SKR55-A	8.12 × 10 ⁻²	8.12 × 10 ⁻²	2.88 × 10 ⁻²
SKR55-B	1.46 × 10 ⁻²	1.46 × 10 ⁻²	2.88 × 10 ⁻²
SKR65-A	7.16 × 10 ⁻²	7.16 × 10 ⁻²	2.21 × 10 ⁻²
SKR65-B	1.27 × 10 ⁻²	1.27 × 10 ⁻²	2.21 × 10 ⁻²

K_A: Moment equivalent factor in the M_A direction.

K_B: Moment equivalent factor in the M_B direction.

K_C: Moment equivalent factor in the M_C direction.

(Note) The values for models SKR-B/D indicate the values when double inner blocks are used in close contact with each other.

Accuracy Standards

The accuracy standard of model SKR is defined in positioning repeatability, positioning accuracy, running parallelism (vertical direction) and backlash.

[Positioning Repeatability]

Command the position to a given arbitrary point. Measure the position and repeat seven times from the same direction. Record the difference between the largest and smallest values. Conduct the same test at three points: the middle of the stroke, and at both the approximate maximum and minimum positions of travel. Express the maximum difference value of the three measurements divided by 2 with a “±” sign.

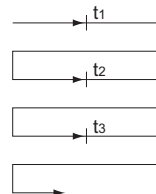

Fig.8 Positioning Repeatability

[Positioning Accuracy]

Using the maximum stroke as the reference length, express the maximum error between the actual distance traveled from the reference point and the command value in an absolute value as positioning accuracy.

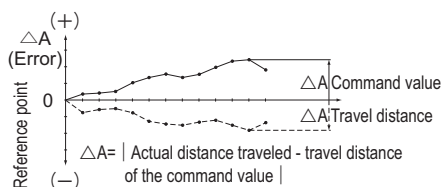

Fig.9 Positioning Accuracy

[Running of Parallelism (Vertical direction)]

Place a straightedge on the surface table where model SKR is mounted, measure almost throughout the travel distance of the inner block using a test indicator. Use the maximum difference among the readings within the travel distance as the running parallelism measurement.

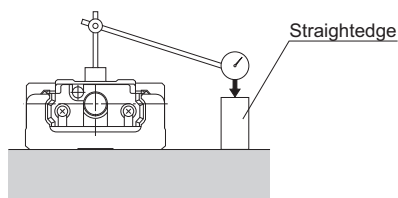

Fig.10 Running of Parallelism

[Backlash]

Feed and slightly move the inner block and read the measurement on the test indicator as the reference value. Subsequently, apply a load to the inner block from the same direction (table feed direction), and then release the inner block from the load. Use the difference between the reference value and the return as the backlash measurement.

Perform this measurement in the center and near both ends, and use the maximum value as the measurement value.

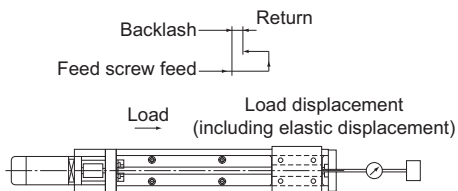

Fig.11 Backlash

The accuracies of model SKR are classified into normal grade (no symbol), high accuracy grade (H) and precision grade (P). Tables below show standards for all the accuracies.

Table11 Normal Grade (No Symbol)

Unit: mm

Model No.	Stroke	Outer rail length	Positioning Repeatability	Positioning Accuracy	Running Parallelism (Vertical Direction)	Backlash	Starting torque (N-cm)
SKR20	30	100	±0.01	No standard defined	No standard defined	0.02	0.5
	80	150					
	130	200					
SKR26	60	150	±0.01	No standard defined	No standard defined	0.02	1.5
	110	200					
	160	250					
	210	300					
SKR33	45	150	±0.01	No standard defined	No standard defined	0.02	7
	95	200					
	195	300					
	295	400					
	395	500					
	495	600					
SKR46	595	700	±0.01	No standard defined	No standard defined	0.02	10
	190	340					
	290	440					
	390	540					
	490	640					
	590	740					
	690	840					
SKR55	790	940	±0.01	No standard defined	No standard defined	0.05	12
	800	980					
	900	1080					
	1000	1180					
	1100	1280					
SKR65	1200	1380	±0.01	No standard defined	No standard defined	0.05	12
	790	980					
	990	1180					
	1190	1380	±0.012				15

*Indicates stroke length when one long-type inner block is incorporated.

Note1) The evaluation method for accuracy standards complies with THK standards.

Note2) The starting torque represents the value when the following grease is used.

Models SKR20 and SKR26 : THK AFA Grease

Models SKR33, SKR46, SKR55 and SKR65 : THK AFB-LF Grease

Note3) If highly viscous grease such as vacuum grease and clean room grease is used, the actual starting torque may exceed the corresponding value in the table. Use much care in selecting a motor.

Note4) Contact THK for accuracy information of units longer than the standard length.

Table12 High Accuracy Grade (H)

Unit: mm

Model No.	Stroke*	Outer rail length	Positioning Repeatability	Positioning Accuracy	Running of Parallelism (Vertical direction)	Backlash	Starting torque (N-cm)
SKR20	30	100	±0.005	0.06	0.025	0.01	0.5
	80	150					
	130	200					
SKR26	60	150	±0.005	0.06	0.025	0.01	1.5
	110	200					
	160	250					
	210	300					
SKR33	45	150	±0.005	0.06	0.025	0.02	7
	95	200					
	195	300					
	295	400		0.10	0.035		
	395	500					
	495	600					
	595	700					
SKR46	190	340	±0.005	0.10	0.035	0.02	10
	290	440					
	390	540					
	490	640		0.12	0.04		
	590	740					
	690	840					
	790	940					
SKR55	800	980	±0.005	0.18	0.05	0.05	12
	900	1080					
	1000	1180		0.25			
	1100	1280					
	1200	1380					
SKR65	790	980	±0.008	0.18	0.05	0.05	12
	990	1180		0.2			
	1190	1380					
	1490	1680		0.28			0.055

*Indicates stroke length when one long-type inner block is incorporated.

Table13 Precision Grade (P)

Unit: mm

Model No.	Stroke*	Outer rail length	Positioning Repeatability	Positioning Accuracy	Running of Parallelism (Vertical direction)	Backlash	Starting torque (N-cm)
SKR20	30	100	±0.003	0.02	0.01	0.003	1.2
	80	150					
	130	200					
SKR26	60	150	±0.003	0.02	0.01	0.003	4
	110	200					
	160	250					
	210	300					
SKR33	45	150	±0.003	0.02	0.01	0.003	15
	95	200					
	195	300					
	295	400		0.025	0.015		
	395	500					
	495	600					
595	700	0.03	0.02				
SKR46	190	340	±0.003	0.025	0.015	0.003	15
	290	440					
	390	540					
	490	640		0.03	0.02		
	590	740					
SKR55	800	980	±0.005	0.035	0.025	0.003	17
	900	1080		0.04	0.03		
	1000	1180					
SKR65	790	980	±0.005	0.035	0.025	0.005	20
	990	1180					
	1190	1380					

*Indicates stroke length when one long-type inner block is incorporated.

Note1) The evaluation method complies with THK standards.

Note2) The starting torque represents the value when the following grease is used.

Models SKR20 and SKR26 : THK AFA Grease

Models SKR33, SKR46, SKR55 and SKR65 : THK AFB-LF Grease

Note3) If harder grease is used, such as vacuum/clean-room grease, the actual starting torque may exceed the values listed.

Note4) Contact THK for information on accuracy for lengths equal to or longer than the standard outer rail.

Model Number Coding

Model No.	Ball Screw Lead	Inner block type	Stroke	Accuracy
SKR33	10	A	0195	P
①	②	③	④	⑤

SKR20	01 : 1mm	A	0025 : 25mm	No symbol: normal grade H : High accuracy grade P : Precision Grade
SKR26	02 : 2mm	B	0050 : 50mm	
SKR33	06 : 6mm	C	∩	
SKR46	10 : 10mm	D	1490 : 1490mm	
SKR55	20 : 20mm			
SKR65	25 : 25mm			
	30 : 30mm			
	40 : 40mm			
	50 : 50mm			

If "2" (with Bellows) was selected for the cover ⑦, specify a stroke incorporating the bellows (→ **A2-47**).

The available ball screw leads differ depending on the model.

SKR20 : "01", "06"

SKR26 : "02", "06"

SKR33 : "06", "10", "20" (20 mm is available for inner block type A and B only)

SKR46 : "10", "20"

SKR55 : "20", "30", "40"

SKR65 : "20", "25", "30", "50"

With/without a motor	Cover	Sensor	Housing A/ Intermediate Flange																																										
0	1	B	AQ																																										
⑥	⑦	⑧	⑨																																										
<table border="1"> <tr> <td>0: direct-coupled (without a motor)</td> </tr> <tr> <td>1: direct-coupled (with a motor, specified by the customer)</td> </tr> </table>	0: direct-coupled (without a motor)	1: direct-coupled (with a motor, specified by the customer)	<table border="1"> <tr> <td>0: without a cover</td> </tr> <tr> <td>1: with a cover</td> </tr> <tr> <td>2: with a bellows</td> </tr> </table>	0: without a cover	1: with a cover	2: with a bellows	<table border="1"> <tr> <td>0: none</td> <td>10</td> </tr> <tr> <td>1</td> <td>20</td> </tr> <tr> <td>2</td> <td>30</td> </tr> <tr> <td>6</td> <td>40</td> </tr> <tr> <td>7</td> <td>60</td> </tr> <tr> <td>B</td> <td>A0</td> </tr> <tr> <td>E</td> <td>A5</td> </tr> <tr> <td>H</td> <td>A6</td> </tr> <tr> <td>L</td> <td>AM</td> </tr> <tr> <td>J</td> <td>AN</td> </tr> <tr> <td>M</td> <td>AP</td> </tr> <tr> <td></td> <td>AQ</td> </tr> <tr> <td></td> <td>AR</td> </tr> <tr> <td></td> <td>AS</td> </tr> <tr> <td></td> <td>AT</td> </tr> <tr> <td></td> <td>AU</td> </tr> <tr> <td></td> <td>AV</td> </tr> <tr> <td></td> <td>AY</td> </tr> <tr> <td></td> <td>AZ</td> </tr> </table>	0: none	10	1	20	2	30	6	40	7	60	B	A0	E	A5	H	A6	L	AM	J	AN	M	AP		AQ		AR		AS		AT		AU		AV		AY		AZ
0: direct-coupled (without a motor)																																													
1: direct-coupled (with a motor, specified by the customer)																																													
0: without a cover																																													
1: with a cover																																													
2: with a bellows																																													
0: none	10																																												
1	20																																												
2	30																																												
6	40																																												
7	60																																												
B	A0																																												
E	A5																																												
H	A6																																												
L	AM																																												
J	AN																																												
M	AP																																												
	AQ																																												
	AR																																												
	AS																																												
	AT																																												
	AU																																												
	AV																																												
	AY																																												
	AZ																																												
<p>If "0" is selected, a coupling is not attached. If a coupling is required, please indicate so.</p> <p>"1" means that a motor specified by the customer is mounted.</p> <p>For item ⑨, select a housing A/intermediate flange that matches the specified motor.</p>																																													
<p>Several motors by different manufacturers can be mounted. Contact THK for details.</p>																																													

A type with a wrap-around housing A and a motor wrap-around type, which are not contained in the catalog, are also available. Contact THK for details.

Model SKR20 Standard Type

Model SKR20□□A (with a Single Long Nut Block)

Model SKR20□□B (with Two Long Nut Blocks)

For model number coding, see **A2-28**.

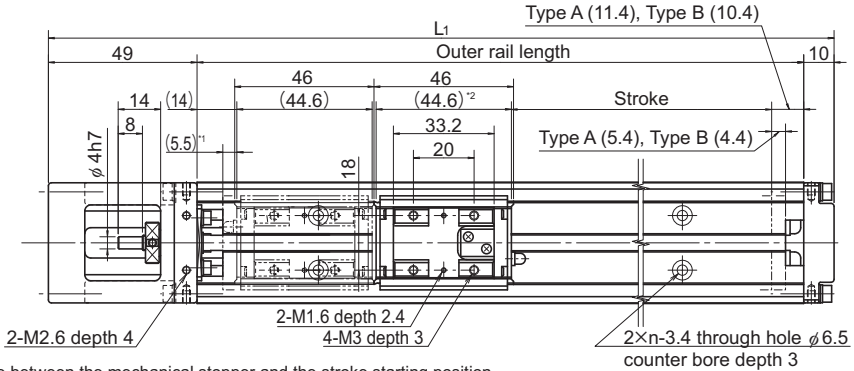

*1 Distance between the mechanical stopper and the stroke starting position.

*2 Indicates the inner block length when calculating the available stroke range. The length in model SKR-B (with two long-type inner blocks) is 90.6 mm.

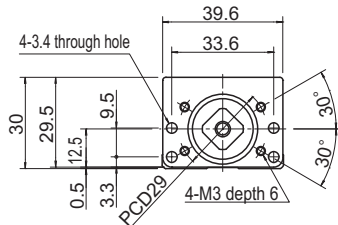
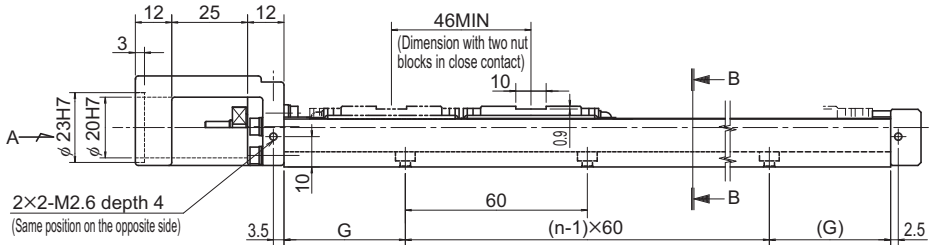

A arrow view

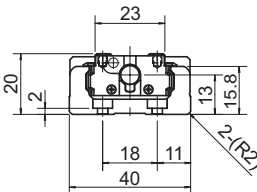

B-B cross section

Stroke (mm) (stroke between mechanical stoppers)		Outer rail length (mm)	Overall length L _t (mm)	G (mm)	n	Overall main unit mass (kg)	
Type A	Type B					Type A	Type B
30(40.9)	—	100	159	20	2	0.45	—
80(90.9)	35(44.9)	150	209	15	3	0.58	0.66
130(140.9)	85(94.9)	200	259	40	3	0.72	0.8

*Indicates a value when two inner blocks are in close contact with each other.

Model SKR20 (with a Cover)

Model SKR20□□A (with a Single Long Nut Block)

Model SKR20□□B (with Two Long Nut Blocks)

For model number coding, see **A2-28**.

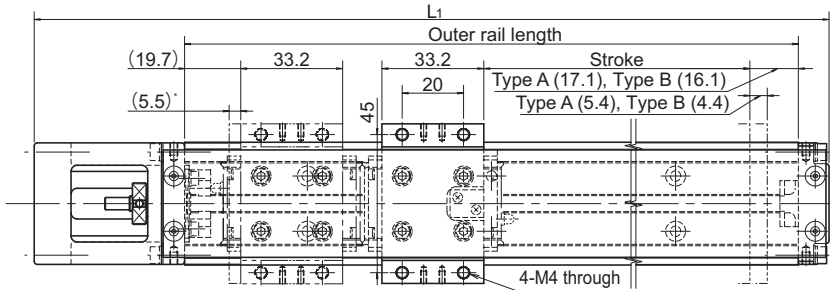

* Distance between the mechanical stopper and the stroke starting position.

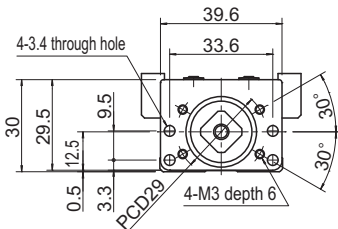
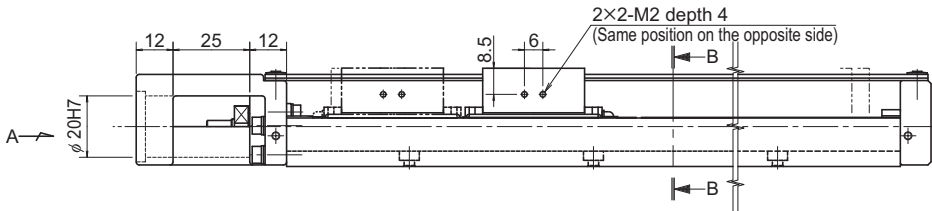

A arrow view

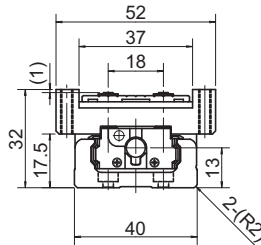

B-B cross section

Stroke (mm) (stroke between mechanical stoppers)		Outer rail length (mm)	Overall length L ₁ (mm)	G (mm)	n	Overall main unit mass (kg)	
Type A	Type B					Type A	Type B
30(40.9)	—	100	159	20	2	0.5	—
80(90.9)	35(44.9)	150	209	15	3	0.64	0.76
130(140.9)	85(94.9)	200	259	40	3	0.79	0.91

*Indicates a value when two inner blocks are in close contact with each other.

Model SKR26 Standard Type

Model SKR26□□A (with a Single Long Nut Block)

Model SKR26□□B (with Two Long Nut Blocks)

For model number coding, see **A2-28**.

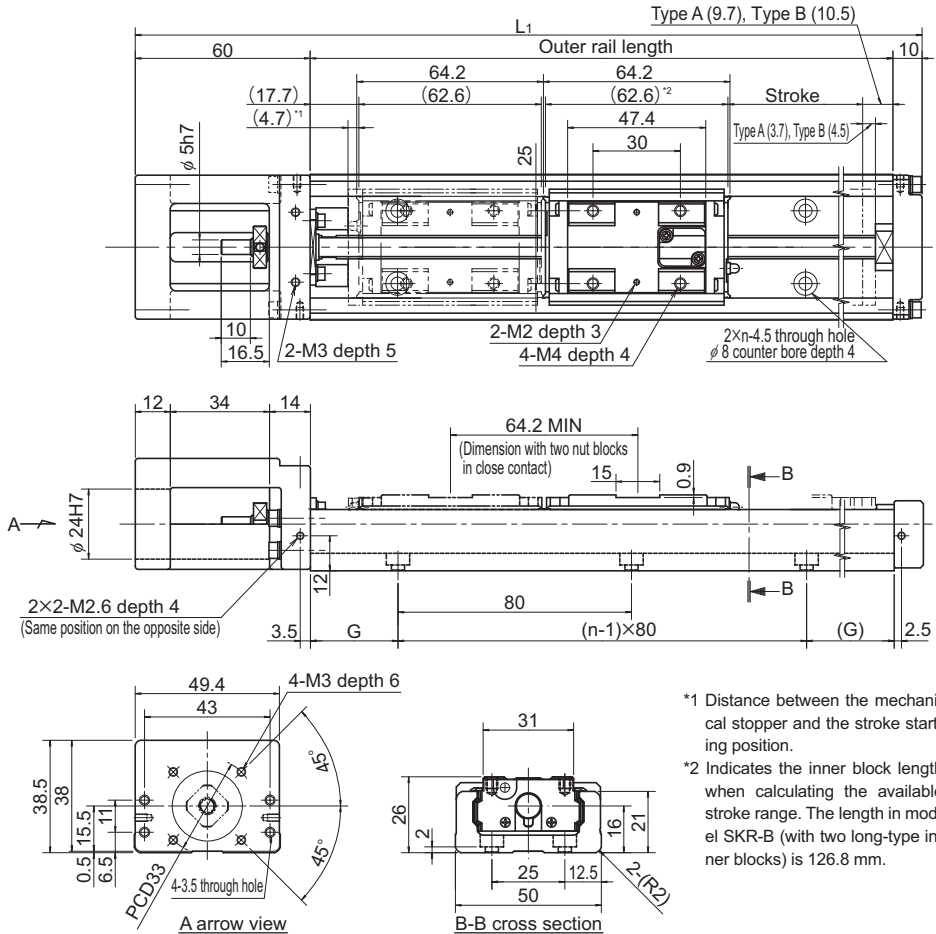

*1 Distance between the mechanical stopper and the stroke starting position.

*2 Indicates the inner block length when calculating the available stroke range. The length in model SKR-B (with two long-type inner blocks) is 126.8 mm.

Stroke (mm) (stroke between mechanical stoppers)		Outer rail length (mm)	Overall length L ₁ (mm)	G (mm)	n	Overall main unit mass (kg)	
Type A	Type B [*]					Type A	Type B
60(68.4)	—	150	220	35	2	0.99	—
110(118.4)	45(54.2)	200	270	20	3	1.2	1.38
160(168.4)	95(104.2)	250	320	45	3	1.41	1.59
210(218.4)	145(154.2)	300	370	30	4	1.62	1.8

*Indicates a value when two inner blocks are in close contact with each other.

Model SKR26 (with a Cover)

Model SKR26□□A (with a Single Long Nut Block)

Model SKR26□□B (with Two Long Nut Blocks)

For model number coding, see **A2-28**.

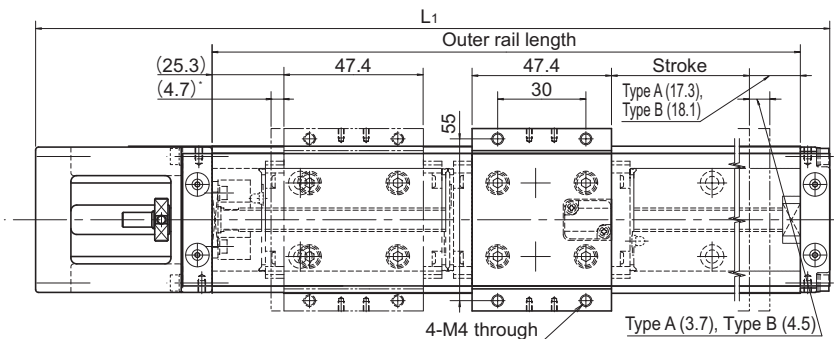

* Distance between the mechanical stopper and the stroke starting position.

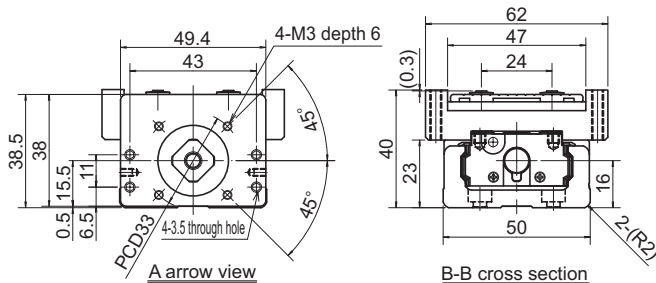
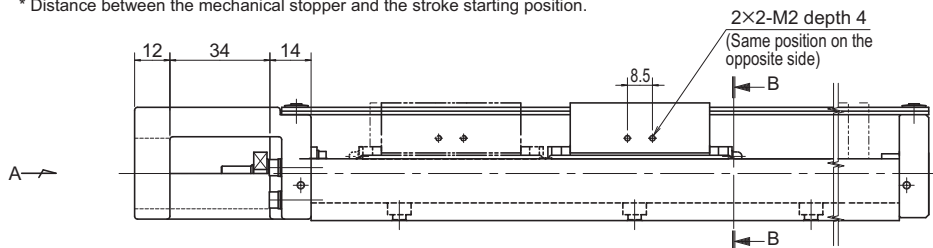

Stroke (mm) (stroke between mechanical stoppers)		Outer rail length (mm)	Overall length L ₁ (mm)	G (mm)	n	Overall main unit mass (kg)	
Type A	Type B*					Type A	Type B
60(68.4)	—	150	220	35	2	1.1	—
110(118.4)	45(54.2)	200	270	20	3	1.32	1.57
160(168.4)	95(104.2)	250	320	45	3	1.54	1.79
210(218.4)	145(154.2)	300	370	30	4	1.76	2.01

*Indicates a value when two inner blocks are in close contact with each other.

Model SKR33 Standard Type

Model SKR33□□A (with a Single Long Nut Block)

Model SKR33□□B (with Two Long Nut Blocks)

For model number coding, see **A2-28**.

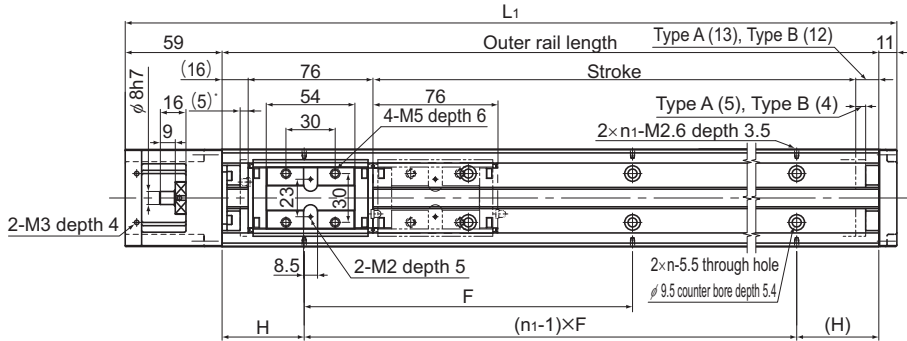

* Distance between the mechanical stopper and the stroke starting position.

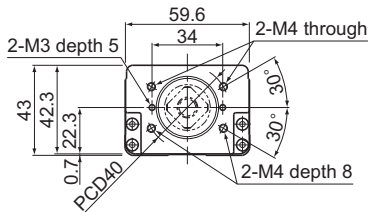
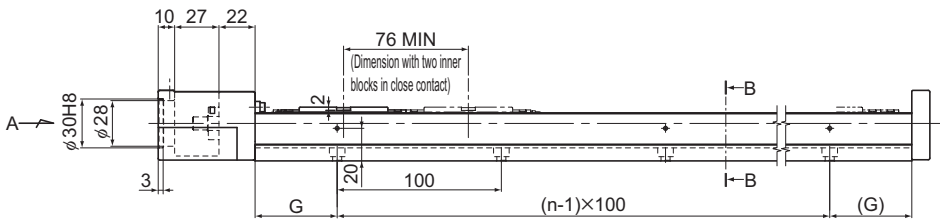

A arrow view

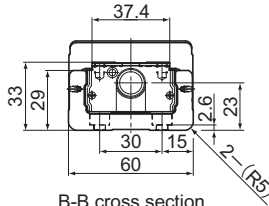

B-B cross section

Stroke (mm) (stroke between mechanical stoppers)		Outer rail length (mm)	Overall length L ₁ (mm)	H (mm)	G (mm)	F (mm)	n	n ₁	Overall main unit mass (kg)	
Type A	Type B								Type A	Type B
45(55)	—	150	220	25	25	100	2	2	1.7	—
95(105)	—	200	270	50	50	100	2	2	2.1	—
195(205)	120(129)	300	370	50	50	200	3	2	2.8	3.1
295(305)	220(229)	400	470	100	50	200	4	2	3.5	3.8
395(405)	320(329)	500	570	50	50	200	5	3	4.2	4.5
495(505)	420(429)	600	670	100	50	200	6	3	5.0	5.3
595(605)	520(529)	700	770	50	50	200	7	4	5.7	6.0

*Indicates a value when two inner blocks are in close contact with each other.

Model SKR33 (with a Cover)

Model SKR33□□A (with a Single Long Nut Block)

Model SKR33□□B (with Two Long Nut Blocks)

For model number coding, see **A2-28**.

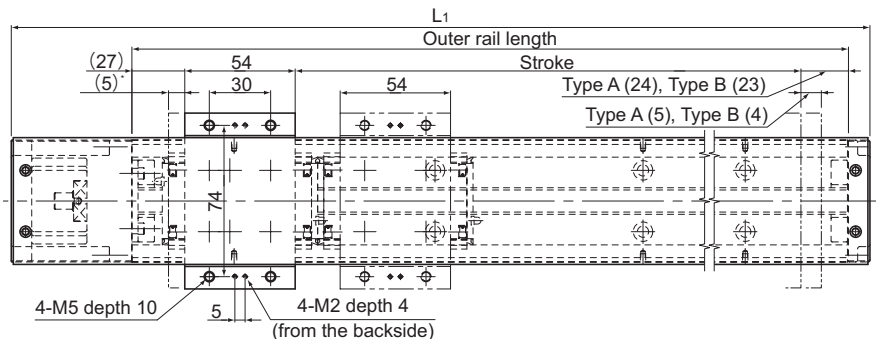

* Distance between the mechanical stopper and the stroke starting position.

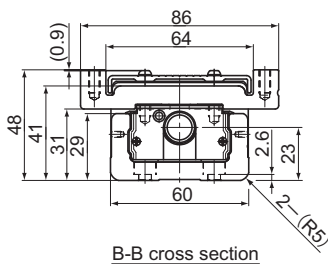
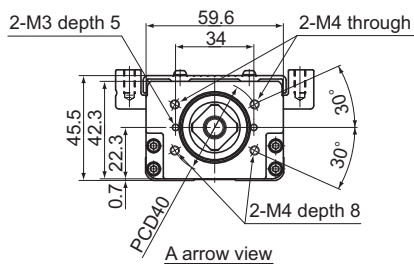
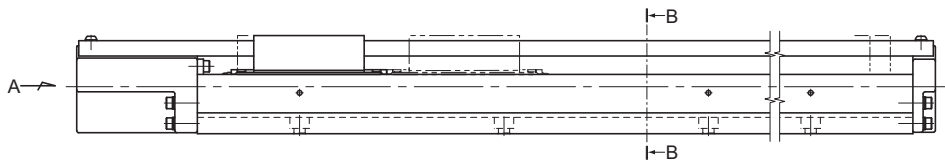

Stroke (mm) (stroke between mechanical stoppers)		Outer rail length (mm)	Overall length L (mm)	H (mm)	G (mm)	F (mm)	n	n ₁	Overall main unit mass (kg)	
Type A	Type B*								Type A	Type B
45(55)	—	150	220	25	25	100	2	2	1.9	—
95(105)	—	200	270	50	50	100	2	2	2.3	—
195(205)	120(129)	300	370	50	50	200	3	2	3.1	3.5
295(305)	220(229)	400	470	100	50	200	4	2	3.8	4.2
395(405)	320(329)	500	570	50	50	200	5	3	4.6	5.0
495(505)	420(429)	600	670	100	50	200	6	3	5.3	5.7
595(605)	520(529)	700	770	50	50	200	7	4	6.1	6.5

*Indicates a value when two inner blocks are in close contact with each other.

Model SKR33 Standard Type

Model SKR33□□C (with a Single Short Nut Block)

Model SKR33□□D (with Two Short Nut Blocks)

For model number coding, see **A2-28**.

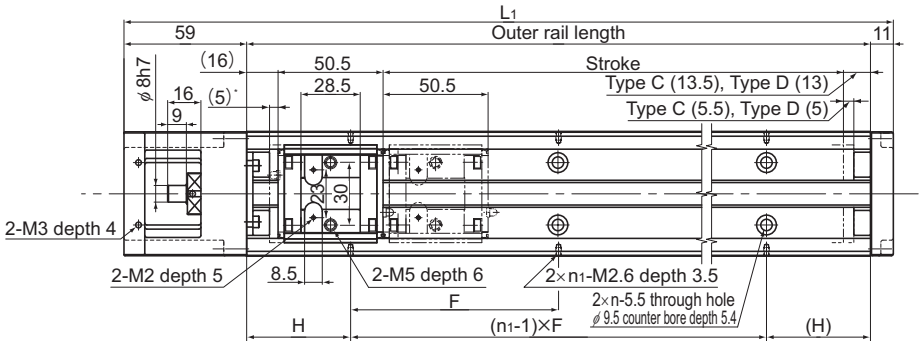

* Distance between the mechanical stopper and the stroke starting position.

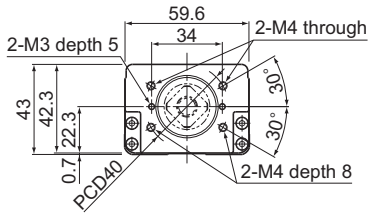
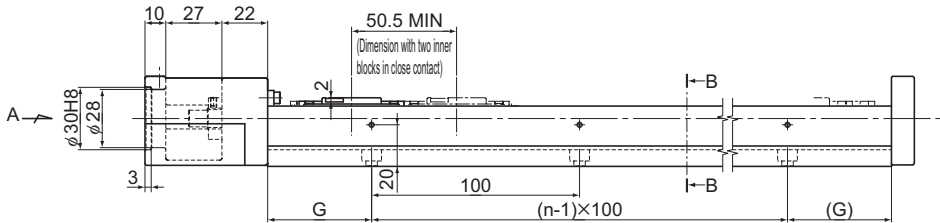

A arrow view

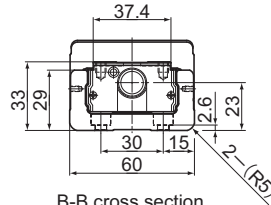

B-B cross section

Stroke (mm) (stroke between mechanical stoppers)		Outer rail length (mm)	Overall length L ₁ (mm)	H (mm)	G (mm)	F (mm)	n	n ₁	Overall main unit mass (kg)	
Type C	Type D								Type C	Type D
70(80.5)	20(30)	150	220	25	25	100	2	2	1.6	1.8
120(130.5)	70(80)	200	270	50	50	100	2	2	2.0	2.1
220(230.5)	170(180)	300	370	50	50	200	3	2	2.7	2.8
320(330.5)	270(280)	400	470	100	50	200	4	2	3.4	3.6
420(430.5)	370(380)	500	570	50	50	200	5	3	4.1	4.3
520(530.5)	470(480)	600	670	100	50	200	6	3	4.8	5.0
620(630.5)	570(580)	700	770	50	50	200	7	4	5.5	5.7

*Indicates a value when two inner blocks are in close contact with each other.

Model SKR33 (with a Cover)

Model SKR33□□C (with a Single Short Nut Block)

Model SKR33□□D (with Two Short Nut Blocks)

For model number coding, see **A2-28**.

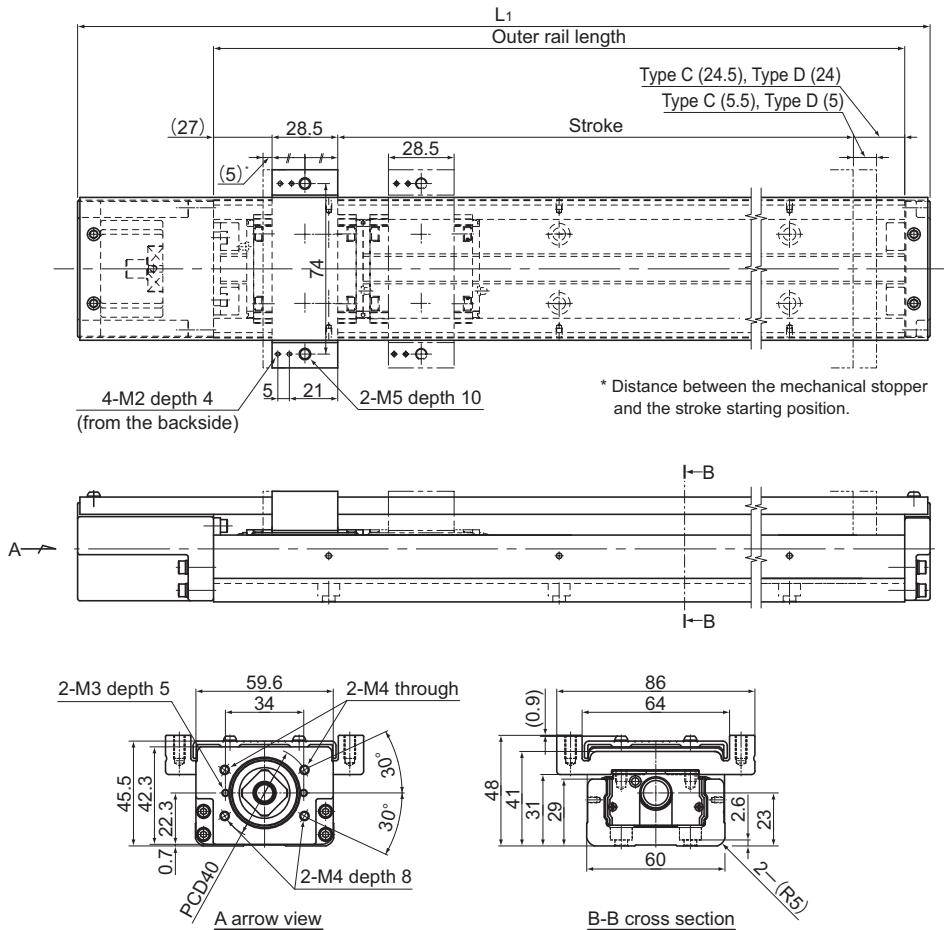

Stroke (mm) (stroke between mechanical stoppers)		Outer rail length (mm)	Overall length L_1 (mm)	H (mm)	G (mm)	F (mm)	n	n_1	Overall main unit mass (kg)	
Type C	Type D*								Type C	Type D
70(80.5)	20(30)	150	220	25	25	100	2	2	1.8	2.0
120(130.5)	70(80)	200	270	50	50	100	2	2	2.2	2.3
220(230.5)	170(180)	300	370	50	50	200	3	2	2.9	3.1
320(330.5)	270(280)	400	470	100	50	200	4	2	3.7	3.8
420(430.5)	370(380)	500	570	50	50	200	5	3	4.4	4.6
520(530.5)	470(480)	600	670	100	50	200	6	3	5.2	5.3
620(630.5)	570(580)	700	770	50	50	200	7	4	5.9	6.1

*Indicates a value when two inner blocks are in close contact with each other.

Model SKR46 Standard Type

Model SKR46□□A (with a Single Long Nut Block)

Model SKR46□□B (with Two Long Nut Blocks)

For model number coding, see **A2-28**.

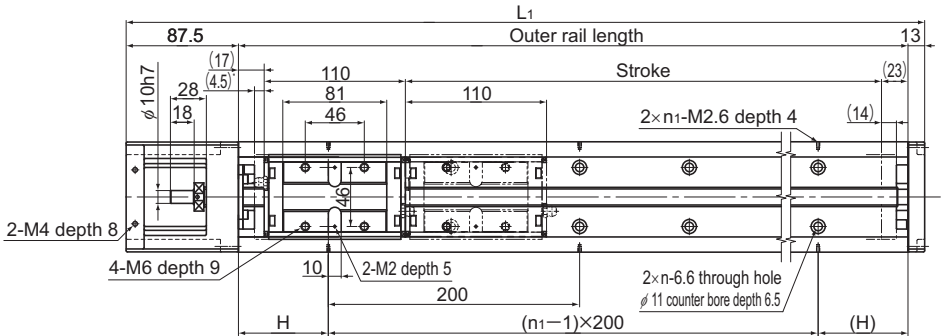

* Distance between the mechanical stopper and the stroke starting position.

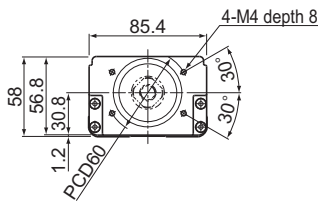
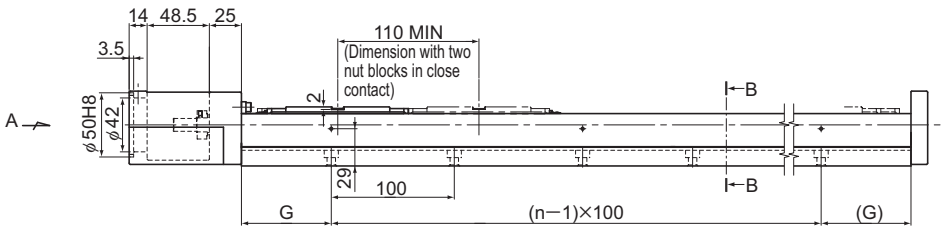

A arrow view

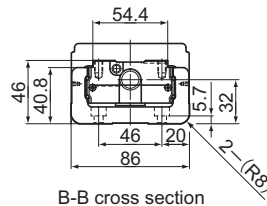

B-B cross section

Stroke (mm) (stroke between mechanical stoppers)		Outer rail length (mm)	Overall length L ₁ (mm)	H (mm)	G (mm)	n	n ₁	Overall main unit mass (kg)	
Type A	Type B							Type A	Type B
190(208.5)	80(98.5)	340	440.5	70	70	3	2	6.4	7.4
290(308.5)	180(198.5)	440	540.5	20	70	4	3	7.8	8.7
390(408.5)	280(298.5)	540	640.5	70	70	5	3	9.2	10.1
490(508.5)	380(398.5)	640	740.5	20	70	6	4	10.6	11.5
590(608.5)	480(498.5)	740	840.5	70	70	7	4	12.0	12.9
690(708.5)	580(598.5)	840	940.5	20	70	8	5	13.4	14.4
790(808.5)	680(698.5)	940	1040.5	70	70	9	5	14.8	15.7

*Indicates a value when two inner blocks are in close contact with each other.

Model SKR46 (with a Cover)

Model SKR46□□A (with a Single Long Nut Block)

Model SKR46□□B (with Two Long Nut Blocks)

For model number coding, see **A2-28**.

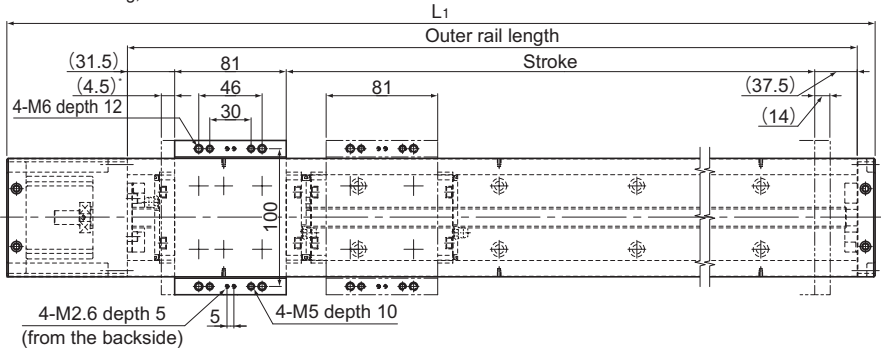

* Distance between the mechanical stopper and the stroke starting position.

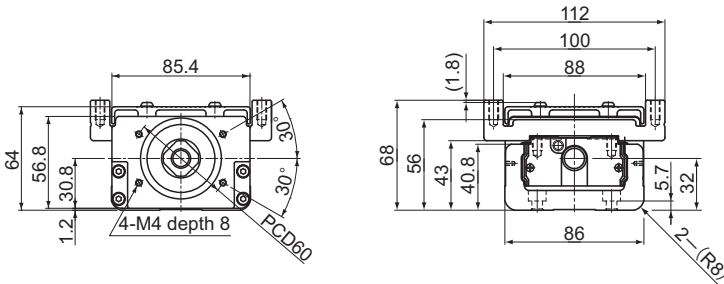
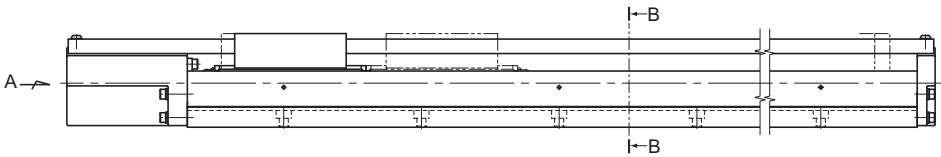

A arrow view

B-B cross section

Stroke (mm) (stroke between mechanical stoppers)		Outer rail length (mm)	Overall length L_1 (mm)	H (mm)	G (mm)	n	n_1	Overall main unit mass (kg)	
Type A	Type B*							Type A	Type B
190(208.5)	80(98.5)	340	440.5	70	70	3	2	7.1	8.3
290(308.5)	180(198.5)	440	540.5	20	70	4	3	8.6	9.8
390(408.5)	280(298.5)	540	640.5	70	70	5	3	10.0	11.3
490(508.5)	380(398.5)	640	740.5	20	70	6	4	11.5	12.7
590(608.5)	480(498.5)	740	840.5	70	70	7	4	13.0	14.2
690(708.5)	580(598.5)	840	940.5	20	70	8	5	14.5	15.7
790(808.5)	680(698.5)	940	1040.5	70	70	9	5	16.0	17.2

*Indicates a value when two inner blocks are in close contact with each other.

Model SKR46 Standard Type

Model SKR46□□C (with a Single Short Nut Block)

Model SKR46□□D (with Two Short Nut Blocks)

For model number coding, see **A2-28**.

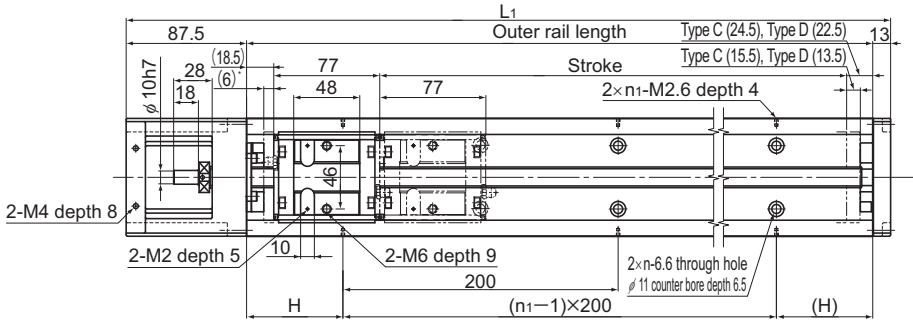

* Distance between the mechanical stopper and the stroke starting position.

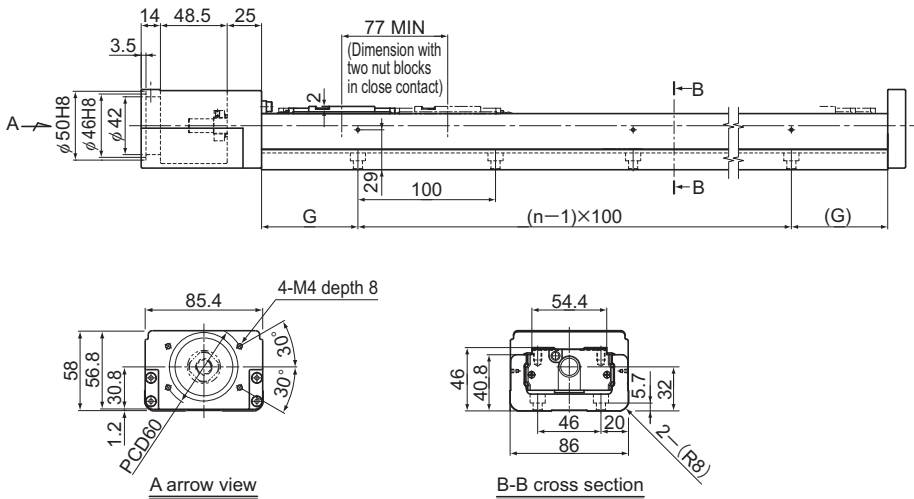

Stroke (mm) (stroke between mechanical stoppers)		Outer rail length (mm)	Overall length L_1 (mm)	H (mm)	G (mm)	n	n_1	Overall main unit mass (kg)	
Type C	Type D							Type C	Type D
220(241.5)	145(164.5)	340	440.5	70	70	3	2	6.1	6.7
320(341.5)	245(264.5)	440	540.5	20	70	4	3	7.5	8.1
420(441.5)	345(364.5)	540	640.5	70	70	5	3	8.9	9.5
520(541.5)	445(464.5)	640	740.5	20	70	6	4	10.3	10.8
620(641.5)	545(564.5)	740	840.5	70	70	7	4	11.7	12.2
720(741.5)	645(664.5)	840	940.5	20	70	8	5	13.1	13.7
820(841.5)	745(764.5)	940	1040.5	70	70	9	5	14.5	15.0

*Indicates a value when two inner blocks are in close contact with each other.

Model SKR46 (with a Cover)

Model SKR46□□C (with a Single Short Nut Block)

Model SKR46□□D (with Two Short Nut Blocks)

For model number coding, see **A2-28**.

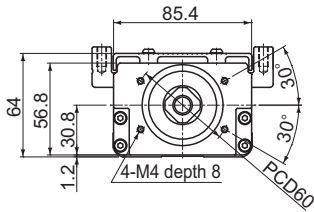
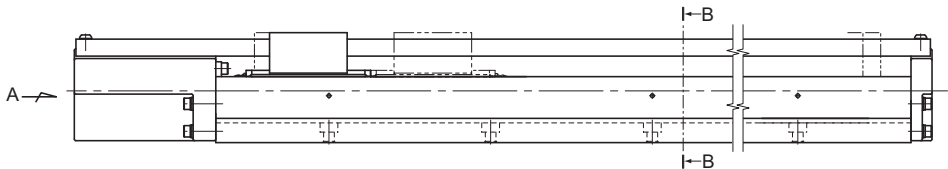
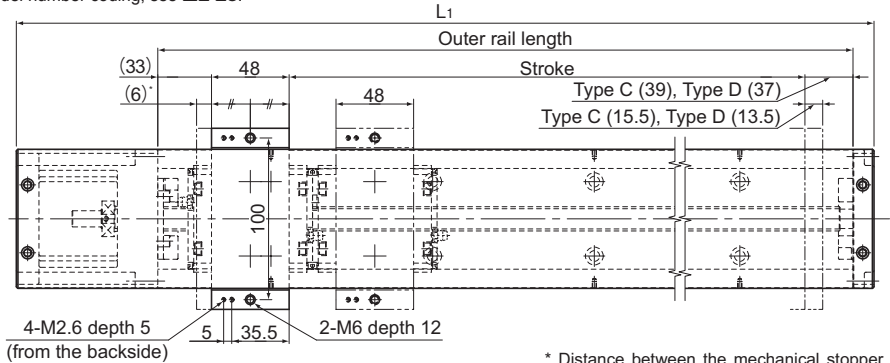

A arrow view

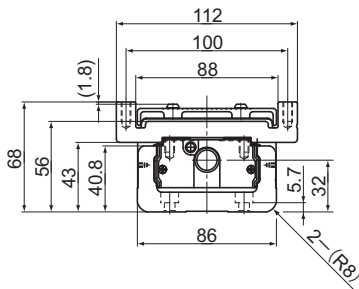

B-B cross section

Stroke (mm) (stroke between mechanical stoppers)		Outer rail length (mm)	Overall length L_1 (mm)	H (mm)	G (mm)	n	n_1	Overall main unit mass (kg)	
Type C	Type D*							Type C	Type D
220(241.5)	145(164.5)	340	440.5	70	70	3	2	6.6	7.4
320(341.5)	245(264.5)	440	540.5	20	70	4	3	8.1	8.9
420(441.5)	345(364.5)	540	640.5	70	70	5	3	9.6	10.3
520(541.5)	445(464.5)	640	740.5	20	70	6	4	11.0	11.8
620(641.5)	545(564.5)	740	840.5	70	70	7	4	12.5	13.3
720(741.5)	645(664.5)	840	940.5	20	70	8	5	14	14.8
820(841.5)	745(764.5)	940	1040.5	70	70	9	5	15.5	16.3

*Indicates a value when two inner blocks are in close contact with each other.

Model SKR55 Standard Type

Model SKR55□□A (with a Single Long Nut Block)

Model SKR55□□B (with Two Long Nut Blocks)

For model number coding, see **A2-28**.

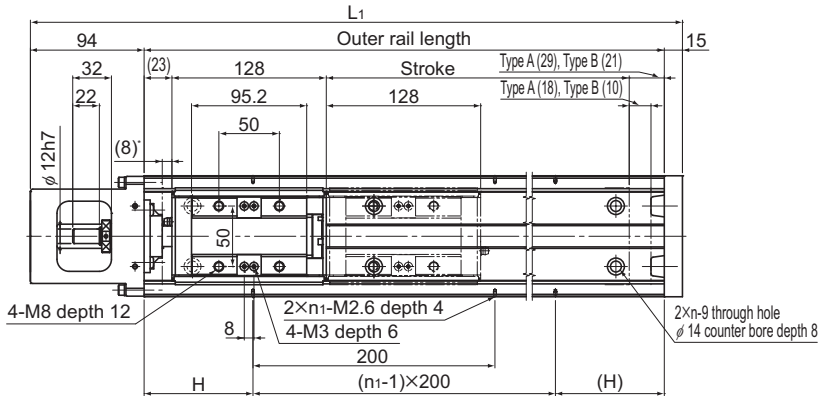

* Distance between the mechanical stopper and the stroke starting position.

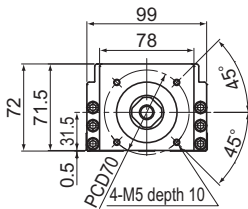
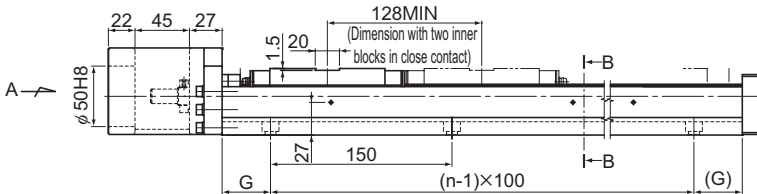

A arrow view

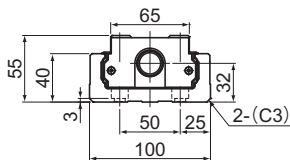

B-B cross section

Stroke (mm) (stroke between mechanical stoppers)		Outer rail length (mm)	Overall length L_1 (mm)	H (mm)	G (mm)	n	n_1	Overall main unit mass (kg)	
Type A	Type B*							Type A	Type B
800 (826)	680 (698)	980	1089	90	40	7	5	20.8	22.7
900 (926)	780 (798)	1080	1189	40	15	8	6	22.6	24.5
1000 (1026)	880 (898)	1180	1289	90	65	8	6	24.4	26.3
1100 (1126)	980 (998)	1280	1389	40	40	9	7	26.1	28
1200 (1226)	1080 (1098)	1380	1489	90	15	10	7	27.9	29.8

*Indicates a value when two inner blocks are in close contact with each other.

Model SKR55 (with a Cover)

Model SKR55□□A (with a Single Long Nut Block)

Model SKR55□□B (with Two Long Nut Blocks)

For model number coding, see **A2-28**.

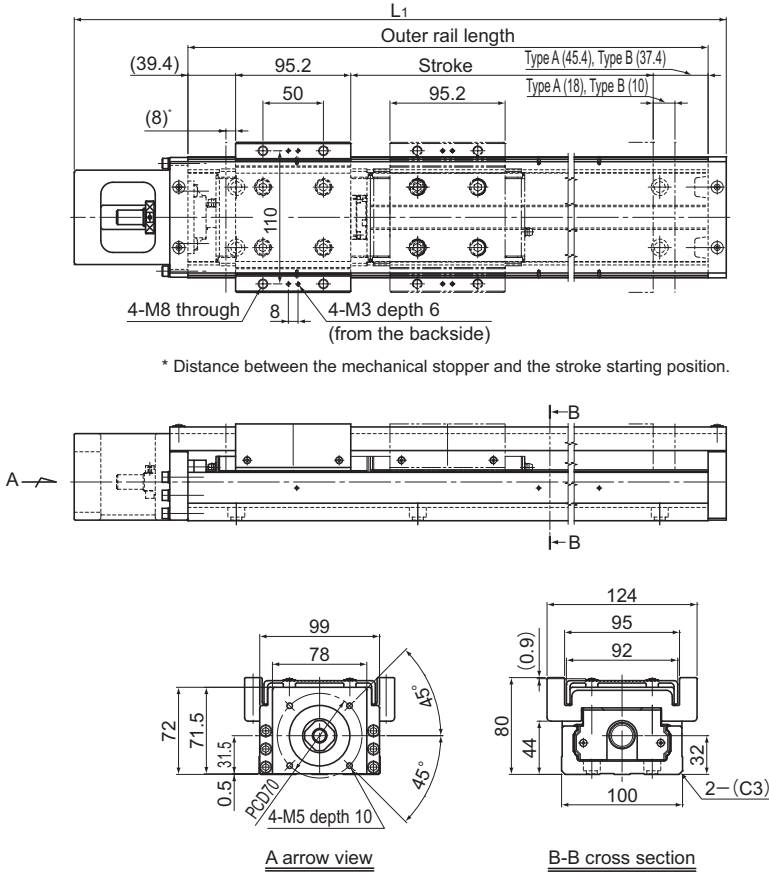

Stroke (mm) (stroke between mechanical stoppers)		Outer rail length (mm)	Overall length L ₁ (mm)	Overall main unit mass (kg)	
Type A	Type B*			Type A	Type B
800 (826)	680 (698)	980	1089	23.8	27.6
900 (926)	780 (798)	1080	1189	25.7	29.5
1000 (1026)	880 (898)	1180	1289	27.6	31.4
1100 (1126)	980 (998)	1280	1389	29.5	33.3
1200 (1226)	1080 (1098)	1380	1489	31.4	35.2

*Indicates a value when two inner blocks are in close contact with each other.

Model SKR65 Standard Type

Model SKR65□□A (with a Single Long Nut Block)

Model SKR65□□B (with Two Long Nut Blocks)

For model number coding, see **A2-28**.

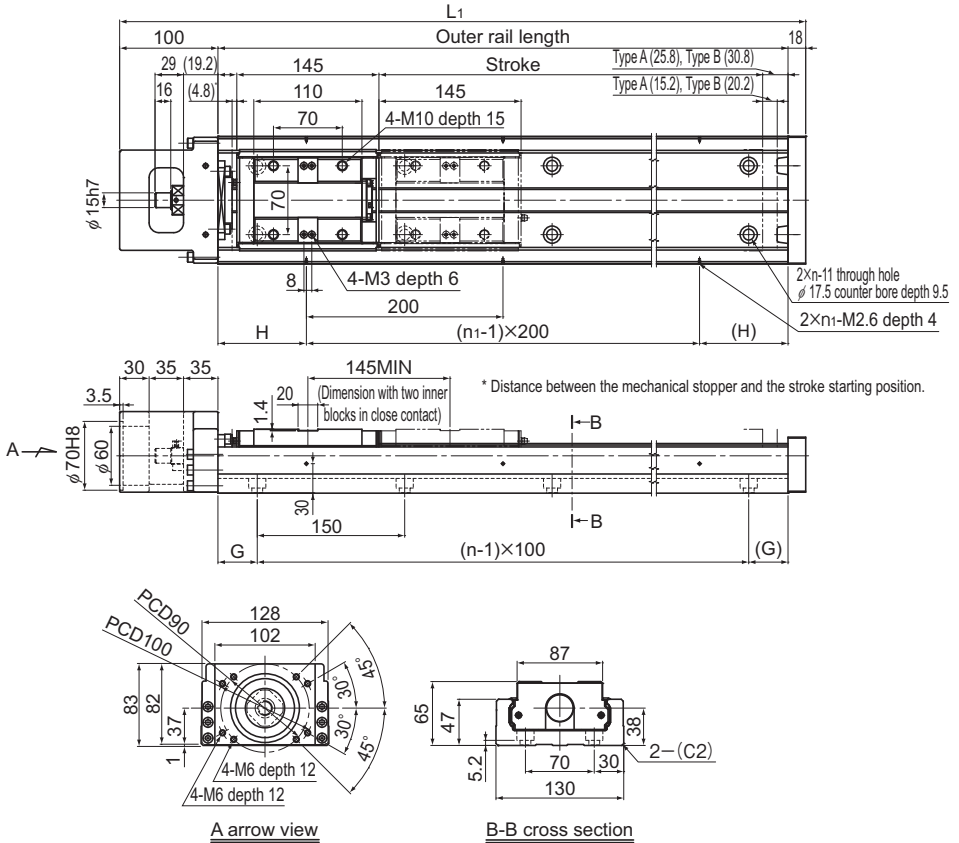

Stroke (mm) (stroke between mechanical stoppers)		Outer rail length (mm)	Overall length L ₁ (mm)	H (mm)	G (mm)	n	n ₁	Overall main unit mass (kg)	
Type A	Type B							Type A	Type B
790 (810)	640 (665)	980	1098	90	40	7	5	30.2	33.2
990 (1010)	840 (865)	1180	1298	90	65	8	6	35.4	38.4
1190 (1210)	1040 (1065)	1380	1498	90	90	9	7	40.6	43.6
1490 (1510)	1340 (1365)	1680	1798	40	90	11	9	48.3	51.3

*Indicates a value when two inner blocks are in close contact with each other.

Model SKR65 (with a Cover)

Model SKR65□□A (with a Single Long Nut Block)

Model SKR65□□B (with Two Long Nut Blocks)

For model number coding, see **A2-28**.

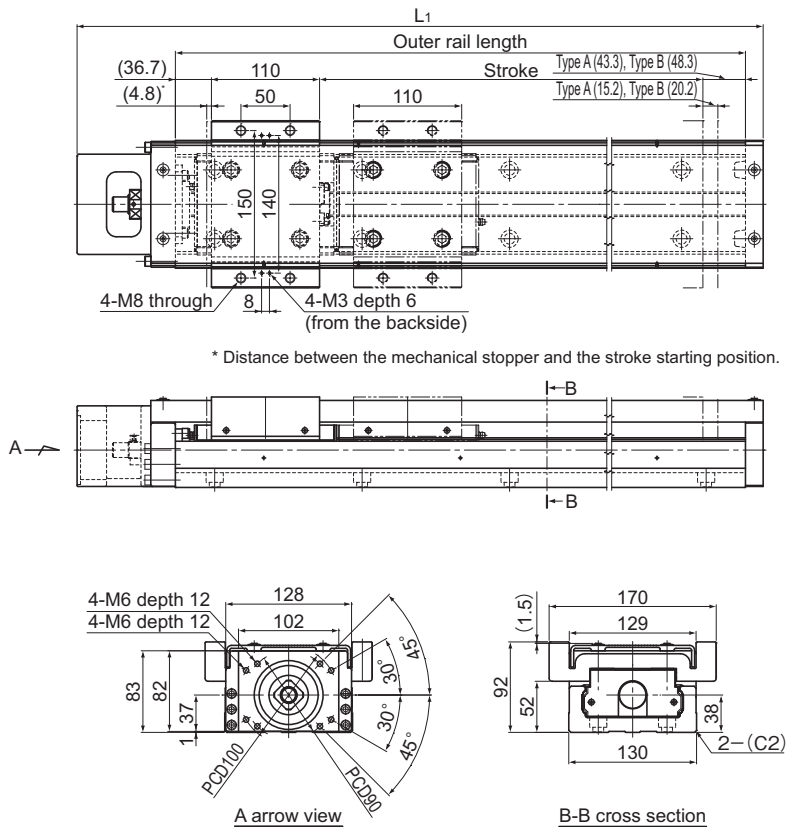

Stroke (mm) (stroke between mechanical stoppers)		Outer rail length (mm)	Overall length L ₁ (mm)	Overall main unit mass (kg)	
Type A	Type B*			Type A	Type B
790 (810)	640 (665)	980	1098	33.4	40.1
990 (1010)	840 (865)	1180	1298	38.9	45.6
1190 (1210)	1040 (1065)	1380	1498	44.3	51
1490 (1510)	1340 (1365)	1680	1798	52.4	59.1

*Indicates a value when two inner blocks are in close contact with each other.

Mass of Moving Element

Table14 shows the mass of the inner block and top table of model SKR.

Table14 Mass of the Inner Block and Top table of SKR

Unit: kg

Model No.	Long nut block types (A)		Short nut block types (C)	
	Inner block	Top table	Inner block	Top table
SKR20	0.064	0.038	—	—
SKR26	0.153	0.074	—	—
SKR33	0.31	0.13	0.17	0.07
SKR46	0.91	0.34	0.57	0.20
SKR55	1.9	1.9	—	—
SKR65	3.0	3.5	—	—

Bellows

For model SKR, bellows are available for contamination protection in addition to a cover.

[Model SKR-A (with a Single Long Nut Block)]

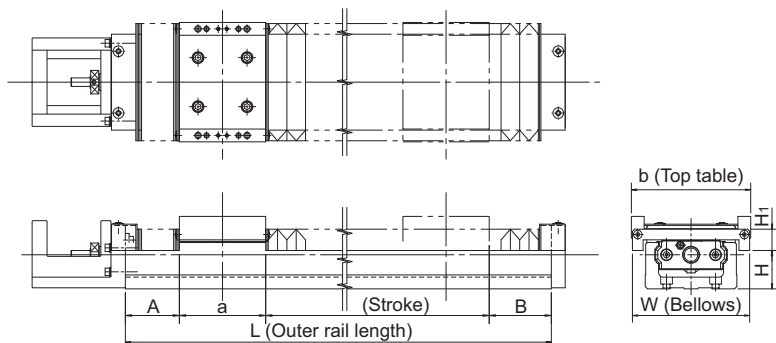

Unit: mm

Model No.	Stroke ^{*1}	Outer rail length L	A	B	a	b	W	H	H ₁
SKR20	20(30.8)	100	18.8	17.2	33.2	52	60	10	20
	55(67.8)	150	25.3	23.7					
	80(93.6)	200	37	36.2					
SKR26	50(60.7)	150	23.7	17.6	47.4	62	74	18	20
	80(91.6)	200	32.8	28.2					
	110(125.6)	250	40.8	36.2					
	160(175.6)	300	40.8	36.2					
SKR33	30(42.8)	150	25.6	27.6	54	86	84	24.5	20
	60(72.8)	200	35.6	37.6					
	140(152.8)	300	45.6	47.6					
	210(222.8)	400	60.6	62.6					
	290(302.8)	500	70.6	72.6					
	360(372.8)	600	85.6	87.6					
SKR46	140(155.8)	340	52.1	51.1	81	112	110	36	20
	210(225.8)	440	67.1	66.1					
	290(305.8)	540	77.1	76.1					
	360(375.8)	640	92.1	91.1					
	440(455.8)	740	102.1	101.1					
	510(525.8)	840	117.1	116.1					
590(605.8)	940	127.1	126.1						

*1 The value in the parentheses represents the maximum stroke.

Unit: mm

Model No.	Stroke ^{*1}	Outer rail length L	A	B	a	b	W	H	H ₁
SKR55 ^{*2}	700 (719.6)	980	84.6	80.6	95.2	124	154	37	40
	790 (809.6)	1080	89.6	85.6					
	870 (889.6)	1180	99.6	95.6					
	960 (979.6)	1280	104.6	100.6					
	1050 (1069.6)	1380	109.6	105.6					
SKR65 ^{*2}	680 (703.2)	980	85.1	81.7	110	170	184	40	47
	860 (883.2)	1180	95.1	91.7					
	1030 (1053.2)	1380	110.1	106.7					
	1290 (1313.2)	1680	130.1	126.7					

*1 The value in the parentheses represents the maximum stroke.

*2 The bellows for models SKR55 and SKR65 are only suitable for horizontal orientation. If the bellows is to be used in other orientations (vertical or wall-mounted), contact THK.

[Model SKR-B (with Two Long Nut Blocks)]

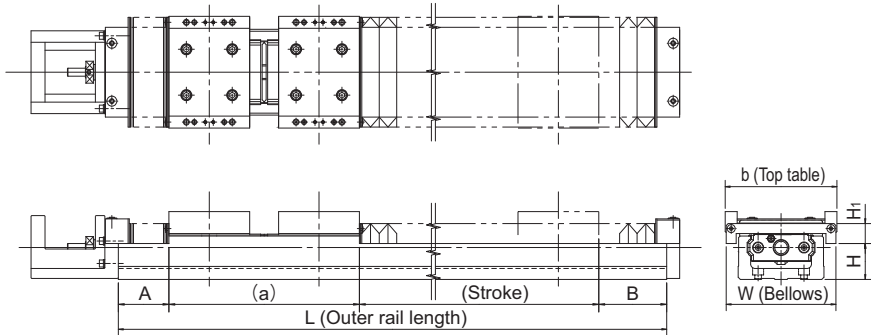

Unit: mm

Model No.	Stroke ^{*1,2}	Outer rail length L	A	B	a	b	W	H	H ₁																																																																																																																				
SKR20	25(34.8)	150	18.8	17.2	79.2	52	60	10	20																																																																																																																				
	60(71.8)	200	25.3	23.7						SKR26	35(46.5)	200	23.7	17.6	111.6	62	74	18	20	65(77.4)	250	32.8	28.2	115(127.4)	300	32.8	28.2	SKR33	80(96.8)	300	35.6	37.6	130	86	84	24.5	20	150(166.8)	400	50.6	52.6	230(246.8)	500	60.6	62.6	300(316.8)	600	75.6	77.6	SKR46	60(75.8)	340	37.1	36.1	191	112	110	36	20	130(145.8)	440	52.1	51.1	210(225.8)	540	62.1	61.1	280(295.8)	640	77.1	76.1	360(375.8)	740	87.1	86.1	430(445.8)	840	102.1	101.1	510(525.8)	940	112.1	111.1	SKR55 ^{*3}	590(612)	980	74.6	70.6	222.8	124	154	37	40	670(692)	1080	84.6	80.6	760(782)	1180	89.6	85.6	850(872)	1280	94.6	90.6	930(952)	1380	104.6	100.6	SKR65 ^{*3}	550(578.6)	980	75.1	71.7	254.6	170	184	40	47	720(748.6)	1180	90.1	86.7	900(928.6)	1380
SKR26	35(46.5)	200	23.7	17.6	111.6	62	74	18	20																																																																																																																				
	65(77.4)	250	32.8	28.2																																																																																																																									
	115(127.4)	300	32.8	28.2																																																																																																																									
SKR33	80(96.8)	300	35.6	37.6	130	86	84	24.5	20																																																																																																																				
	150(166.8)	400	50.6	52.6																																																																																																																									
	230(246.8)	500	60.6	62.6																																																																																																																									
	300(316.8)	600	75.6	77.6																																																																																																																									
SKR46	60(75.8)	340	37.1	36.1	191	112	110	36	20																																																																																																																				
	130(145.8)	440	52.1	51.1																																																																																																																									
	210(225.8)	540	62.1	61.1																																																																																																																									
	280(295.8)	640	77.1	76.1																																																																																																																									
	360(375.8)	740	87.1	86.1																																																																																																																									
	430(445.8)	840	102.1	101.1																																																																																																																									
	510(525.8)	940	112.1	111.1																																																																																																																									
SKR55 ^{*3}	590(612)	980	74.6	70.6	222.8	124	154	37	40																																																																																																																				
	670(692)	1080	84.6	80.6																																																																																																																									
	760(782)	1180	89.6	85.6																																																																																																																									
	850(872)	1280	94.6	90.6																																																																																																																									
	930(952)	1380	104.6	100.6																																																																																																																									
SKR65 ^{*3}	550(578.6)	980	75.1	71.7	254.6	170	184	40	47																																																																																																																				
	720(748.6)	1180	90.1	86.7																																																																																																																									
	900(928.6)	1380	100.1	96.7																																																																																																																									
	1160(1188.6)	1680	120.1	116.7																																																																																																																									

*1 The strokes in the table are values when the blocks are in close contact with each other.

*2 The value in the parentheses represents the maximum stroke.

*3 The bellows for models SKR55 and SKR65 are only suitable for horizontal orientation. If the bellows is to be used in other orientations (vertical or wall-mounted), contact THK.

Note) The bellows cannot be attached between the top tables.

[Model SKR-C (with a Single Short Nut Block)]

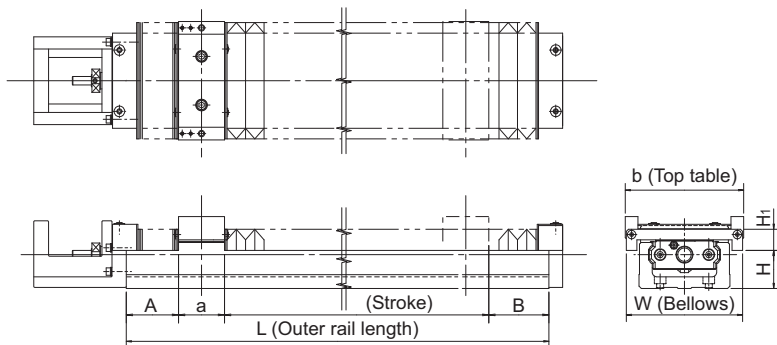

Unit: mm

Model No.	Stroke*	Outer rail length L	A	B	a	b	W	H	H ₁
SKR33	45(58.3)	150	30.6	32.6	28.5	80	80	21.5	17.5
	85(98.3)	200	35.6	37.6					
	155(168.3)	300	50.6	52.6					
	235(248.3)	400	60.6	62.6					
	385(398.3)	600	85.6	87.6					
SKR46	160(178.8)	340	57.1	56.1	48	112	110	36	20
	230(248.8)	440	72.1	71.1					
	310(328.8)	540	82.1	81.1					
	380(398.8)	640	97.1	96.1					
	460(478.8)	740	107.1	106.1					
	530(548.8)	840	122.1	121.1					
610(628.8)	940	132.1	131.1						

*The value in the parentheses represents the maximum stroke.

[Model SKR-D (with Two Short Nut Blocks)]

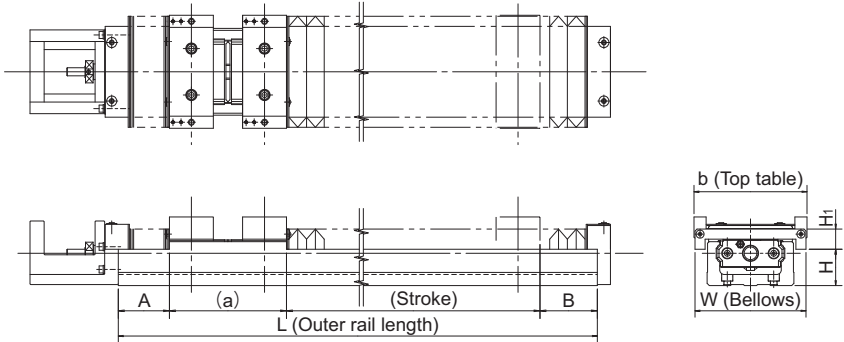

Unit: mm

Model No.	Stroke ^{*1,2}	Outer rail length L	A	B	a	b	W	H	H ₁
SKR33	45(57.8)	200	30.6	32.6	79	86	84	24.5	20
	125(137.8)	300	40.6	42.6					
	195(207.8)	400	55.6	57.6					
	275(287.8)	500	65.6	67.6					
	345(357.8)	600	80.6	82.6					
SKR46	110(121.8)	340	47.1	46.1	125	112	110	36	20
	180(191.8)	440	62.1	61.1					
	260(271.8)	540	72.1	71.1					
	330(341.8)	640	87.1	86.1					
	410(421.8)	740	97.1	96.1					
	480(491.8)	840	112.1	111.1					
	560(571.8)	940	122.1	121.1					

*1 The strokes in the table are values when the blocks are in close contact with each other.

*2 The value in the parentheses represents the maximum stroke.

Note) The bellows cannot be attached between the top tables.

Sensor

Optional photo sensors and proximity sensors are available for SKR models.

[Example of Installation]

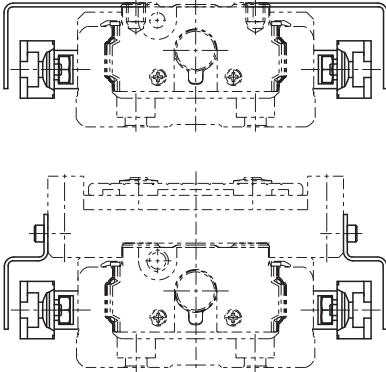

Table15 With/without a sensor

Symbol	Description	Type	Accessory ^{*1}
0	None	—	—
1	With sensor rail	—	Mounting screws, sensor rail
2	Photo Sensor ^{*2} [3 units]	EE-SX671 (Omron Corp.)	Mounting screw/nut, detecting plate, sensor rail, mounting plate, connector (EE-1001)
6	Photo Sensor ^{*2} [3 units]	EE-SX674 (Omron Corp.)	Mounting screw/nut, detecting plate, sensor rail, mounting plate, connector (EE-1001)
7	Proximity Sensor N.O. contact [3 units]	APM-D3A1-001 (Azbil Corp.)	Mounting screw/nut, detecting plate, sensor rail
B	Proximity Sensor N.C. contact [3 units]	APM-D3B1-003 (Azbil Corp.)	Mounting screw/nut, detecting plate, sensor rail
E	Proximity Sensor N.O. contact [1 unit] N.C. contact [2 units]	APM-D3A1-001 APM-D3B1-003 (Azbil Corp.)	Mounting screw/nut, detecting plate, sensor rail
H	Proximity Sensor N.O. contact [3 units]	GX-F12A (Panasonic Industrial Devices SUNX Co., Ltd.)	Mounting screw/nut, detecting plate, sensor rail
L	Proximity Sensor N.C. contact [3 units]	GX-F12B (Panasonic Industrial Devices SUNX Co., Ltd.)	Mounting screw/nut, detecting plate, sensor rail
J	Proximity Sensor N.O. contact [1 unit] N.C. contact [2 units]	GX-F12A GX-F12B (Panasonic Industrial Devices SUNX Co., Ltd.)	Mounting screw/nut, detecting plate, sensor rail
M	Proximity Sensor N.O. contact [1 unit] N.C. contact [2 units]	GX-F12A-P GX-F12B-P (Panasonic Industrial Devices SUNX Co., Ltd.)	Mounting screw/nut, detecting plate, sensor rail

N.O. contact: normally open contact

N.C. contact: normally closed contact

*1 If the stroke is less than 70 mm, 2 sensor flags and 2 sensor rails will be included. SKR20 and 26 ship with the sensor rail already installed.

*2 The photo-sensors can be switched between ON when lit and ON when unlit.

[Proximity Sensor]

APM-D3A1-001 (Azbil Corp.) 3 units

APM-D3B1-003 (Azbil Corp.) 3 units

GX-F12A (Panasonic Industrial Devices SUNX Co., Ltd.) 3 units

GX-F12B (Panasonic Industrial Devices SUNX Co., Ltd.) 3 units

GX-F12A-P (Panasonic Industrial Devices SUNX Co., Ltd.) 3 units

GX-F12B-P (Panasonic Industrial Devices SUNX Co., Ltd.) 3 units

● Proximity Sensor: APM-D3A1-001 APM-D3B1-003 (Azbil Corp.)

Unit: mm

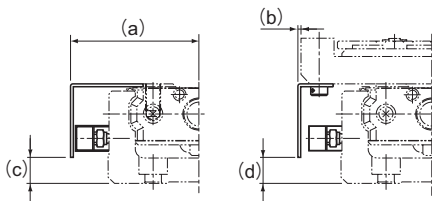

Model No.	a	b	c	d
SKR20	32.5	6.6	6	6
SKR26	37.5	6.4	8	8
SKR33	43	0.3	14.8	15
SKR46	56.2	0.2	26.8	22
SKR55	62.4	0.4	22	22
SKR65	77.4	-7.6	25.1	25

● Proximity sensor GX-F12A GX-F12B GX-F12A-P GX-F12B-P (Panasonic Industrial Devices SUNX Co., Ltd.)

Unit: mm

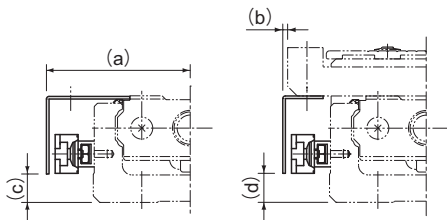

Model No.	a	b	c	d
SKR20	34	8.1	3.6	4
SKR26	39	7.9	6	6
SKR33	44.7	2	13.8	15
SKR46	57.7	1.8	24.8	22
SKR55	64.5	2.5	22	22
SKR65	79	-6	25.1	25

● Proximity Sensor (with Bellows)

Unit: mm

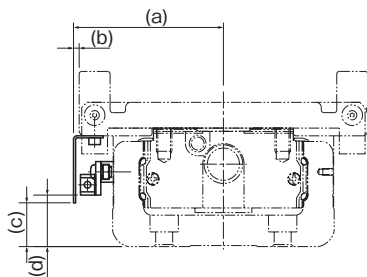

Model No.	a	b	c	d	Sensor type
SKR33	47	4	8	6	GX-F12 (Panasonic Industrial Devices SUNX Co., Ltd.)
SKR46	59.8	3.8	15	15	
SKR33	45.3	2.3	10	11	APM-D3 (Azbil Corp.)
SKR46	56.2	0.2	22	25	

[Photo Sensor]

EE-SX671 (Omron Corp.) 3 units

EE-SX674 (Omron Corp.) 3 units

Connector EE-1001 (Omron Corp.) 3 units

Note) The connector is an appended article.

● Photo Sensor: EE-SX671 (Omron Corp.)

Unit: mm

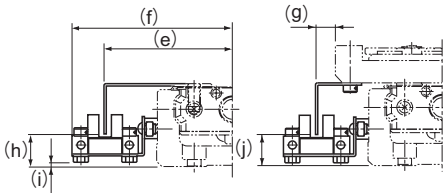

Model No.	e	f	g	h	i	j
SKR20	41	53.8	15	9.4	0.9	9.5
SKR26	45.9	58.7	14.9	11.4	2.9	11.5
SKR33	51.1	63.6	8.3	18.8	7.4	19.5
SKR46	64.1	76.6	8.3	29.8	16.4	26.5
SKR55	70.7	83.5	8.6	24.5	13.6	25
SKR65	85.5	98.5	0.6	28.1	16.6	28

● Photo Sensor: EE-SX674 (Omron Corp.)

Unit: mm

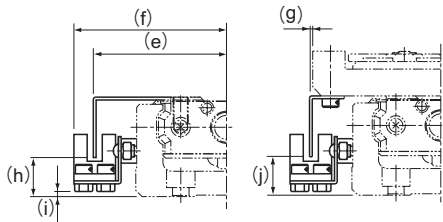

Model No.	e	f	g	h	i	j
SKR20	38.3	44.8	12.5	10.9	0.6	11
SKR26	43.3	49.7	12.5	12.9	2.6	13
SKR33	45.9	52.1	3.3	17.8	7.1	20
SKR46	58.9	65.1	3.2	28.8	16.1	27
SKR55	63.5	70.5	1.5	24.5	13.1	24
SKR65	79	85.5	-6	28.6	16.1	28

● Photo Sensor (with Bellows)

Unit: mm

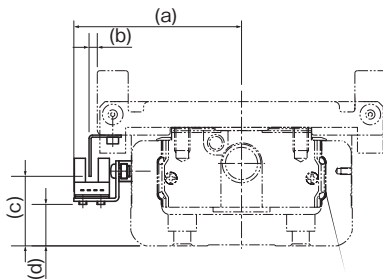

Model No.	a	b	c	d	Sensor type
SKR33	63.6	8.3	19.5	7.4	EE-SX671 (Omron Corp.)
SKR46	76.6	8.3	26.5	16.4	
SKR33	52.1	3.3	18	5.1	EE-SX674 (Omron Corp.)
SKR46	65.1	3.2	27	16.1	

[Sensor Rail]

The sensor rail can be attached alone.

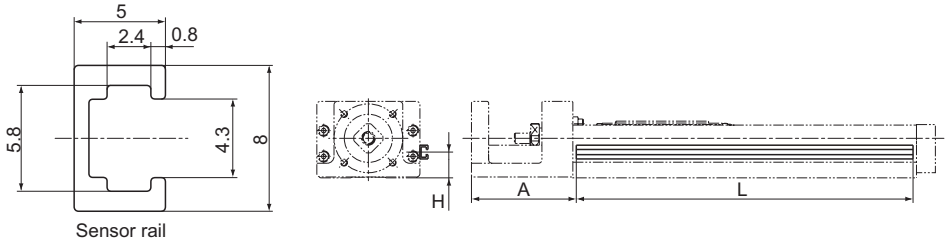

Sensor rail

Unit: mm

Model No.	Stroke*	Outer rail length	H	A	L
SKR20	30	100	10	43	111
	80	150			161
	130	200			211
SKR26	60	150	12	54	161
	110	200			211
	160	250			261
	210	300			311
SKR33	45	150	20	61	146
	95	200			196
	195	300			296
	295	400			396
	395	500			496
	495	600			596
	595	700			696
SKR46	190	340	29	89.5	336
	290	440			436
	390	540			536
	490	640			636
	590	740			736
	690	840			836
SKR55	790	940	27	96	936
	800	980			976
	900	1080			1076
	1000	1180			1176
	1100	1280			1276
SKR65	1200	1380	30	102	1376
	790	980			976
	990	1180			1176
	1190	1380			1376
	1490	1680			1676

*Indicates stroke length when one long-type inner block is incorporated.

Housing

THK also offers Housing A provided with a separate motor, and a turnaround type of Housing A, as options in order to support a motor bracket or a turnaround section that the customer may separately produce.

[Housing A for a Separate Motor]

By using the fitting difference, the user can easily mount a separately manufactured motor bracket.

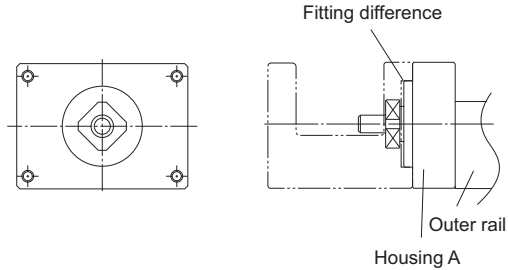

[Turnaround Housing A]

Since the mounting holes are drilled in constant pitches, the user can easily select a direction to mount the turnaround section.

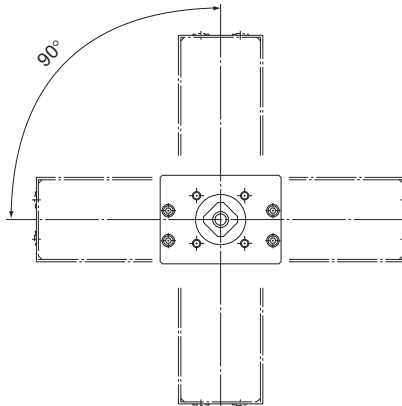

Intermediate Flange

[Motor Used and Applicable Intermediate Flanges for Model SKR]

Several types of intermediate flanges for mounting motors are available for model SKR. Specify an intermediate flange that matches the motor used.

Each intermediate flange is made of steel and provided with THK AP-C treatment, a surface treatment that provides excellent corrosion resistance.

Table16 Table of Motors Used and Corresponding Intermediate Flanges

Motor type		Rated output	Flange size	SKR20	SKR26	SKR33	SKR46	SKR55	SKR65				
AC servo motor	Yaskawa Electric	Σ-7	□25	SGMMV-A1	10W	AN	AN	—	—	—			
				SGMMV-A2	20W	AN	AN	—	—	—			
				SGMMV-A3	30W	AN	AN	—	—	—			
			□40	SGMJV-A5	50W	AQ	AQ	AQ	AQ	—	—		
				SGMAV-A5		AQ	AQ	AQ	AQ	—	—		
				SGMJV-01	100W	□40	AQ	AQ	AQ	AQ	—	—	
			SGMAV-01	100W	□40	AQ	AQ	AQ	AQ	—	—		
			SGMJV-C2	150W	□40	—	—	AQ	AQ	—	—		
			SGMJV-02	200W	□60	—	—	—	AV	A0	AV		
		SGMAV-02	—			—	—	AV	A0	AV			
		SGMJV-04	400W	□60	—	—	—	AV	A0	AV			
		SGMAV-04			—	—	—	AV	A0	AV			
		SGMJV-06	550W	□60	—	—	—	AV	A0	AV			
		SGMJV-08	750W	□80	—	—	—	—	AZ	AZ			
		SGMAV-08			—	—	—	—	AZ	AZ			
		Mitsubishi Electric	MELSERVO	Σ-7	□40	SGM7J-A5	50W	AQ	AQ	AQ	AQ	—	—
						SGM7A-A5		AQ	AQ	AQ	AQ	—	—
					□40	SGM7J-01	100W	—	—	AQ	AQ	—	—
	SGM7A-01					—		—	AQ	AQ	—	—	
	□40				SGM7J-C2	150W	—	—	AQ	AQ	—	—	
					SGM7J-02		—	—	—	AV	A0	AV	
	□60				SGM7A-02	200W	—	—	—	AV	A0	AV	
					SGM7J-04		—	—	—	AV	A0	AV	
	□60				SGM7A-04	400W	—	—	—	AV	A0	AV	
				SGM7J-06	550W		□60	—	—	—	AV	A0	AV
	□80			SGM7J-08	750W	—	—	—	—	AZ	AZ		
				SGM7A-08		—	—	—	—	AZ	AZ		
	J3			HF-MP053	50W	□40	AQ	AQ	AQ	AQ	—	—	
				HF-KP053			AQ	AQ	AQ	AQ	—	—	
				HF-MP13	100W	□40	—	—	AQ	AQ	—	—	
				HF-KP13			—	—	AQ	AQ	—	—	
				HF-MP23	200W	□60	—	—	—	AV	A0	AV	
				HF-KP23			—	—	—	AV	A0	AV	
		HF-MP43	400W	□60	—	—	—	AV	A0	AV			
		HF-KP43			—	—	—	AV	A0	AV			
		HF-MP73	750W	□80	—	—	—	—	AZ	AZ			
HF-KP73	—	—			—	—	AZ	AZ					
J4	HG-AK0136	10W	□25	AN	AN	—	—	—	—				
	HG-AK0236	20W		AN	AN	—	—	—	—				
	HG-AK0336	30W		AN	AN	—	—	—	—				
	HG-MR053	50W	□40	AQ	AQ	AQ	AQ	—	—				
	HG-KR053			AQ	AQ	AQ	AQ	—	—				
	HG-MR13	100W	□40	—	—	AQ	AQ	—	—				
	HG-KR13			—	—	AQ	AQ	—	—				
	HG-MR23	200W	□60	—	—	—	AV	A0	AV				
	HG-KR23			—	—	—	AV	A0	AV				
	HG-MR43	400W	□60	—	—	—	AV	A0	AV				
	HG-KR43			—	—	—	AV	A0	AV				
	HG-MR73	750W	□80	—	—	—	—	AZ	AZ				
	HG-KR73			—	—	—	—	AZ	AZ				

Motor type			Rated output	Flange size	SKR20	SKR26	SKR33	SKR46	SKR55	SKR65		
AC servo motor	Mitsubishi Electric	MELSERVO	JN	HF-KN053	50W		AQ	AQ	AQ	AQ	—	—
				HF-KN13	100W	□40	—	—	AQ	AQ	—	—
			HF-KN23	200W		—	—	—	AV	A0	AV	
			HF-KN43	400W	□60	—	—	—	AV	A0	AV	
	Tamagawa Seiki Co., Ltd.	TBL-II	TS4602	50W		AQ	AQ	AQ	AQ	—	—	
			TS4603	100W	□40	—	—	AQ	AQ	—	—	
			TS4604	150W		—	—	AQ	AQ	—	—	
			TS4607	200W		—	—	—	AV	A0	AV	
			TS4609	400W	□60	—	—	—	AV	A0	AV	
			TS4614	750W	□80	—	—	—	—	AZ	AZ	
			TSM3101	30W		AQ	AQ	—	—	—	—	
		TSM3102	50W	□40	AQ	AQ	AQ	AQ	—	—		
		TSM3104	100W		—	—	AQ	AQ	—	—		
		TSM3202	200W		—	—	—	AV	A0	AV		
		TSM3204	400W	□60	—	—	—	AV	A0	AV		
		TSM3303	600W		—	—	—	—	AZ	AZ		
		TSM3304	750W	□80	—	—	—	—	AZ	AZ		
		Panasonic Corp.	MINAS	A5	MSMD5A	50W	□38	AP	AP	AP	AP	—
	MSME5A						AP	AP	AP	AP	—	—
	MSMD01				100W	□38	—	—	AP	AP	—	—
	MSME01						—	—	AP	AP	—	—
	MSMD02					200W	□60	—	—	—	AY	—
	MSME02				—		—	—	AY	—	—	
	MSMD04			400W	□60	—	—	—	AY	—	—	
	MSME04					—	—	—	AY	—	—	
	MSMD08				750W	□80	—	—	—	—	A5	A5
	MSME08					—	—	—	—	A5	A5	
A6	MSMF5A		50W	□38	AP	AP	AP	AP	—	—		
	MHMF5A			□40	AQ	AQ	AQ	AQ	—	—		
	MSMF01		100W	□38	—	—	AP	AP	—	—		
	MHMF01			□40	—	—	AQ	AQ	—	—		
	MSMF02			200W	□60	—	—	—	AY	—	—	
	MHMF02				—	—	—	AY	—	—		
	MSMF04		400W		□60	—	—	—	AY	—	—	
	MHMF04				—	—	—	AY	—	—		
	MSMF08			750W	□80	—	—	—	—	A5	A5	
MHMF08		—	—		—	—	A5	A5				
Keyence Corporation	SV	SV-M005	50W		AQ	AQ	AQ	AQ	—	—		
		SV-M010	100W	□40	—	—	AQ	AQ	—	—		
		SV-M020	200W		—	—	—	AV	A0	AV		
		SV-M040	400W	□60	—	—	—	AV	A0	AV		
		SV-M075	750W	□80	—	—	—	—	AZ	AZ		
	SV2	SV2-M005	50W		AQ	AQ	AQ	AQ	—	—		
		SV2-M010	100W	□40	—	—	AQ	AQ	—	—		
		SV2-M020	200W		—	—	—	AV	A0	AV		
		SV2-M040	400W	□60	—	—	—	AV	A0	AV		
		SV2-M075	750W	□80	—	—	—	—	AZ	AZ		
SANYO DENKI	SANMOTION R	R2□A04003	30W		AQ	AQ	—	—	—	—		
		R2□A04005	50W	□40	AQ	AQ	AQ	AQ	—	—		
		R2EA04008	80W		—	—	AQ	AQ	—	—		
		R2□A04010	100W		—	—	AQ	AQ	—	—		
		R2□A06020	200W		—	—	—	AV	A0	AV		
		R2AA06040	400W	□60	—	—	—	AV	A0	AV		
		R2AA08075	750W	□80	—	—	—	—	AZ	AZ		

		Motor type		Rated output	Flange size	SKR20	SKR26	SKR33	SKR46	SKR55	SKR65		
AC servo motor	Omron	OMNUC5	R88M-K05030	50W	□40	AQ	AQ	AQ	AQ	—	—		
			R88M-K10030	100W		—	—	AQ	AQ	—	—		
			R88M-K20030	200W		—	—	—	AY	—	—		
			R88M-K40030	400W		—	—	—	AY	—	—		
		R88M-K75030	750W	□80	—	—	—	—	A5	A5			
		R88M-1M10030	100W	□40	—	—	AQ	AQ	—	—			
		R88M-1M20030	200W	□60	—	—	—	AY	—	—			
		R88M-1M40030	400W		—	—	—	AY	—	—			
	R88M-1M75030	750W	—		—	—	—	A5	A5				
	Fanuc	β isseries	βis0.2/5000		50W	□40	AQ	AQ	AQ	AQ	—	—	
			βis0.3/5000		100W		—	—	AQ	AQ	—	—	
	Stepping motor	Oriental Motor	αStep	AZ2 *, AR2 *		□28	AS	AS	—	—	—	—	
				AZ4 *, AR4 *		□42	AR	AR	AR	—	—	—	
				AZ6 *, AR6 *		□60	—	—	AU	AU	—	—	
AZ9 *, AR9 *				□85	—	—	—	—	A6	A6			
5 phase			CRK	CRK52 *		□28	AS	AS	—	—	—	—	
				CRK54 *		□42	AR	AR	AR	—	—	—	
				CRK56 *		□60	—	—	AU	AU	—	—	
			CSK II	CSK59 *		□85	—	—	—	—	A6	A6	
				RK II	RKS54 *		□42	AR	AR	AR	—	—	—
					RKS56 *		□60	—	—	AU	AU	—	—
			RKS59 *		□85	—	—	—	—	A6	A6		
			PKA	PKA544		□42	AR	AR	AR	—	—	—	
				PKA566		□60	—	—	AU	AU	—	—	
				CVK	CVK52 *		□28	AS	AS	—	—	—	
					CVK54 *		□42	AR	AR	AR	—	—	
					CVK56 *		□60	—	—	AU	AU	—	—
2 phase				CMK	CMK22 *		□28	AS	AS	—	—	—	
			CMK24 *		□42	AR	AR	AR	—	—			
			CMK26 *		□56.4	—	—	AT	—	—			
			CVK	CVK22 *		□28	AS	AS	—	—	—		
				CVK24 *		□42	AR	AR	AR	—	—		
				CVK26 *		□56.4	—	—	AT	—	—		
SANYO DENKI			PB	PBDM28 *		□28	AS	AS	—	—	—		
				PBDM423, PBA * *423		□42	AR	AR	AR	—	—		
				PBDM60 *, PBA * *60 *		□60	—	—	AU	AU	—	—	
			5 phase	FAF/FDF52 *		□28	AS	AS	—	—	—		
				FAF54 */FDF54 */FA511M42/FB511M42		□42	AR	AR	AR	—	—		
				FAM56 */FDM56 */FA512M60/FA512M60		□60	—	—	AU	AU	—	—	
			2 phase	D * 14S28 *		□28	AS	AS	—	—	—		
				DB14H52 *		□42	AR	AR	AR	—	—		
				DU15H52 *			AR	AR	AR	—	—		
				D * 16H71 *		□56.4	—	—	AT	—	—		
			DB16H78 *		□60	—	—	AU	AU	—	—		
			Keyence Corporation	2 phase	QS-M28		□28	AS	AS	—	—	—	
QS-M42					□42	AR	AR	AR	—	—			
QS-M60					□60	—	—	AU	AU	—	—		

Note 1) The symbols in the table indicate the housing A and intermediate flange.

Note 2) For motor coupling, contact THK.

Note 3) The motor types in the table represent only some of the types available. For details regarding different types, please see the catalog from each respective motor manufacturer.

[Dimensional Drawing of Housing A/Intermediate Flange for Model SKR]

● For Model SKR20

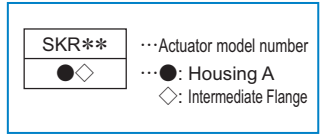

■ Housing A

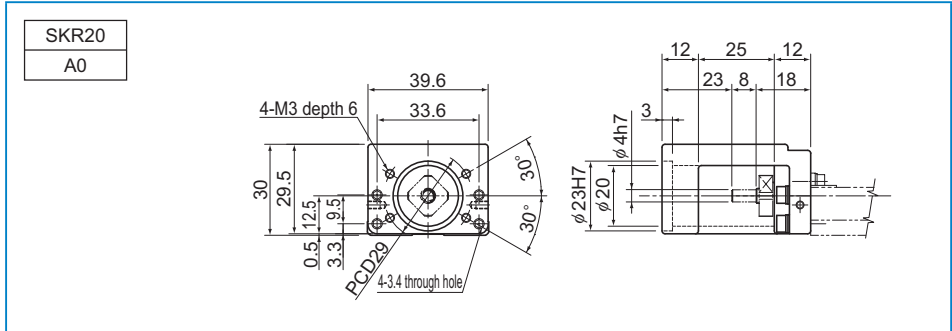

■ Intermediate Flange

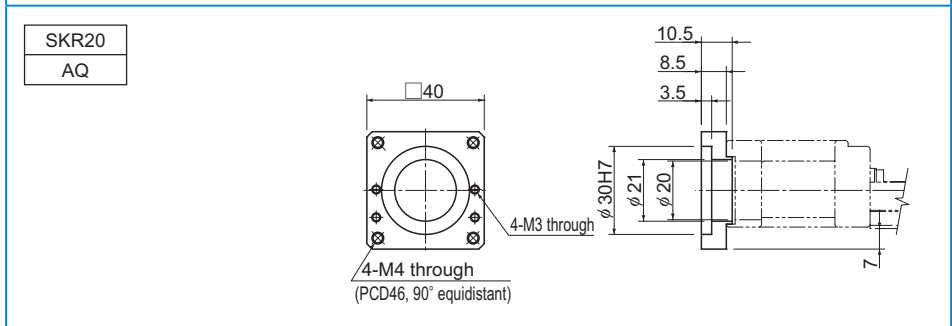
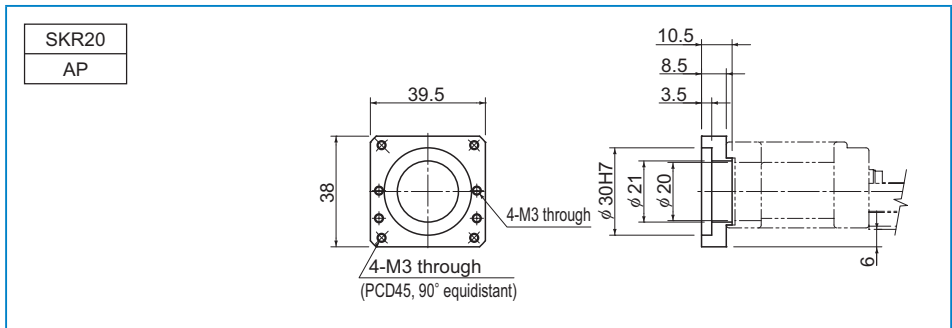

SKR20

AR

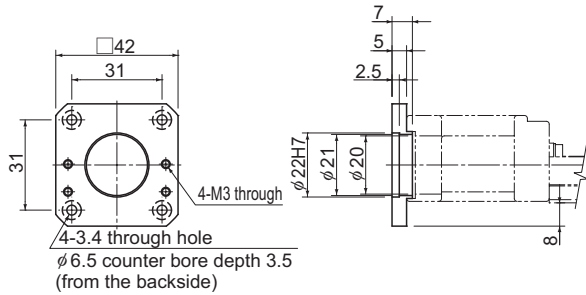

SKR20

AS

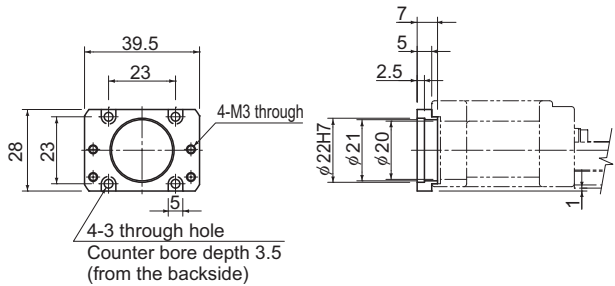

SKR20

AM

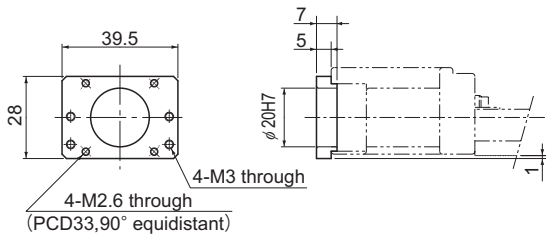

SKR20

AN

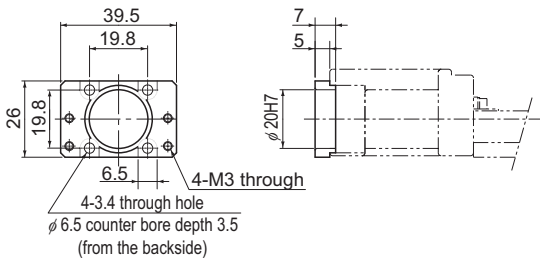

● For Model SKR26

SKR**	···· Actuator model number
● ◇	···· ●: Housing A ◇: Intermediate Flange

■ Housing A

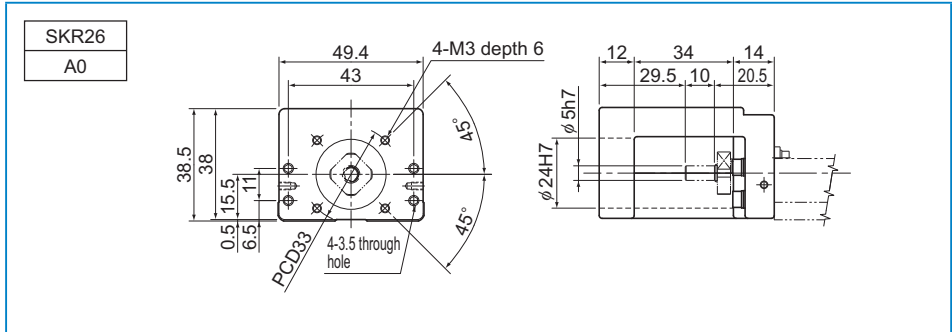

■ Intermediate Flange

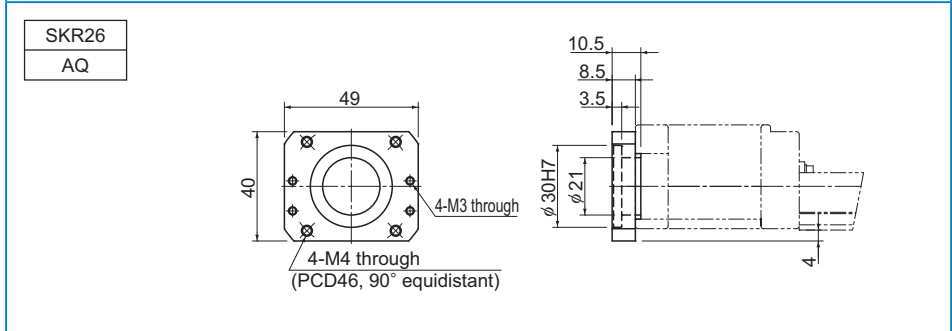
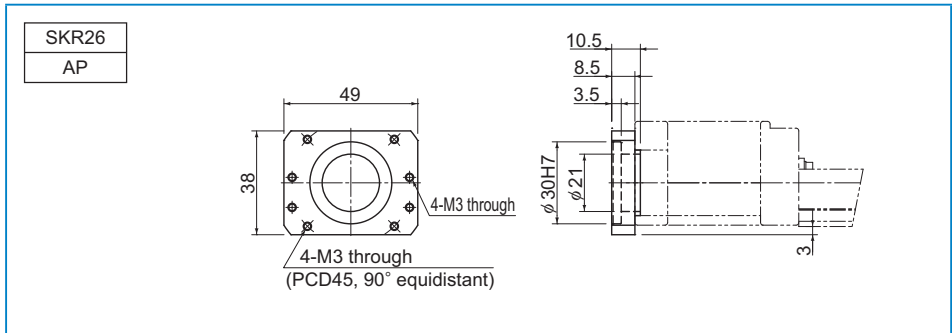

SKR26

AR

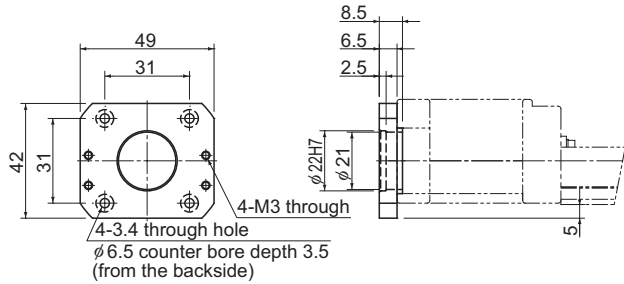

SKR26

AS

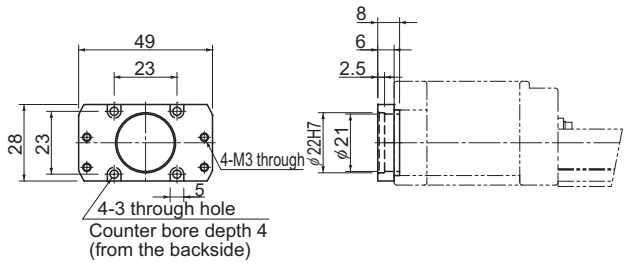

SKR26

AM

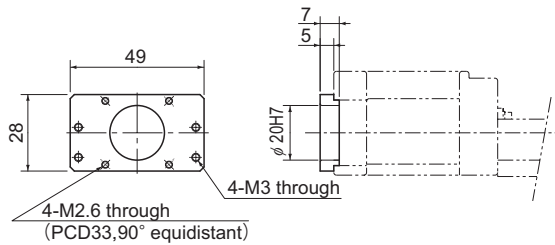

SKR26

AN

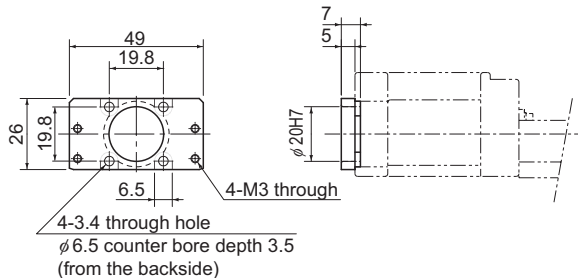

● For Model SKR33

SKR**	···· Actuator model number
● ◆	····●: Housing A ◆: Intermediate Flange

■ Housing A

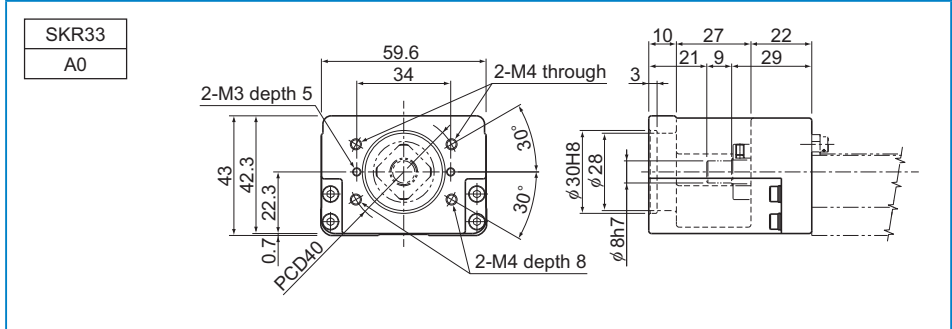

■ Intermediate Flange

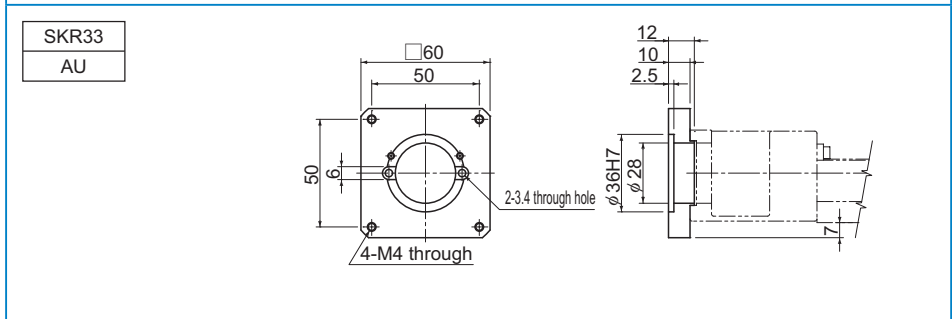
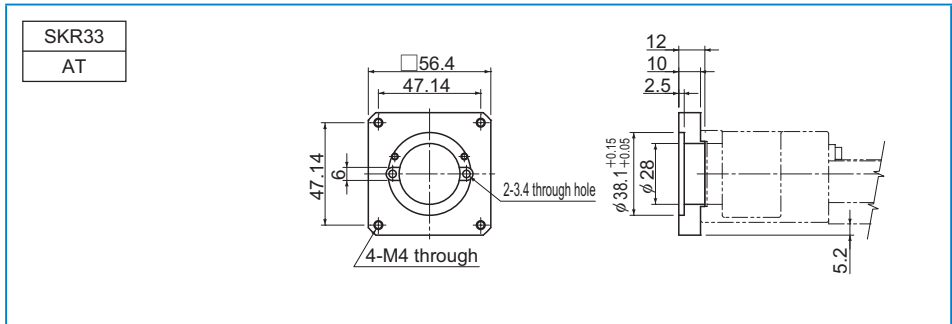

SKR33

AQ

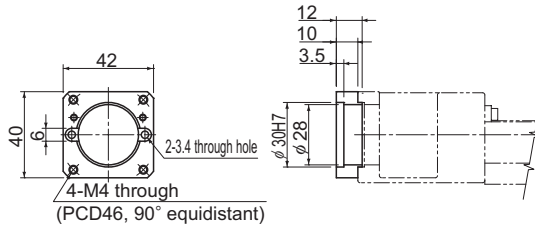

SKR33

AR

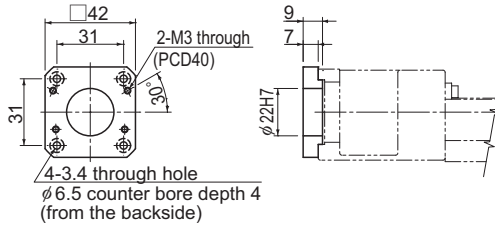

SKR33

AP

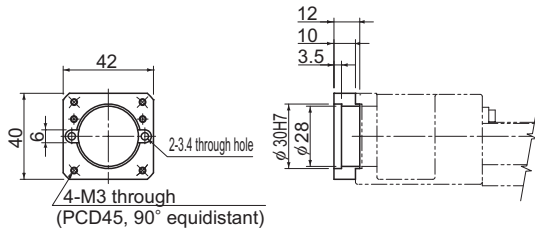

● For Model SKR46

SKR**	...Actuator model number
● ◆	...●: Housing A ◆: Intermediate Flange

■ Housing A

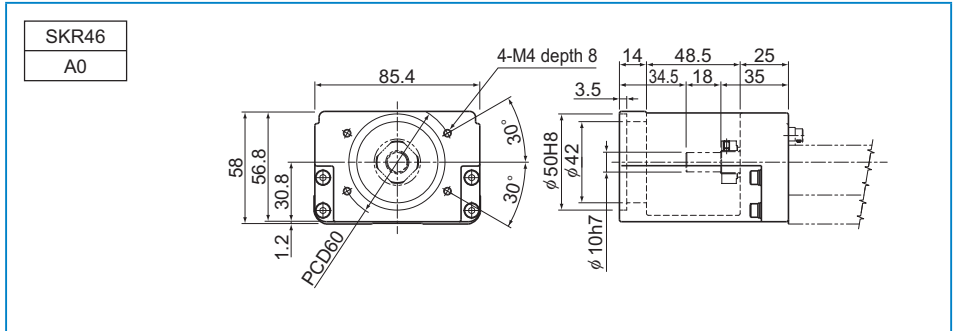

■ Intermediate Flange

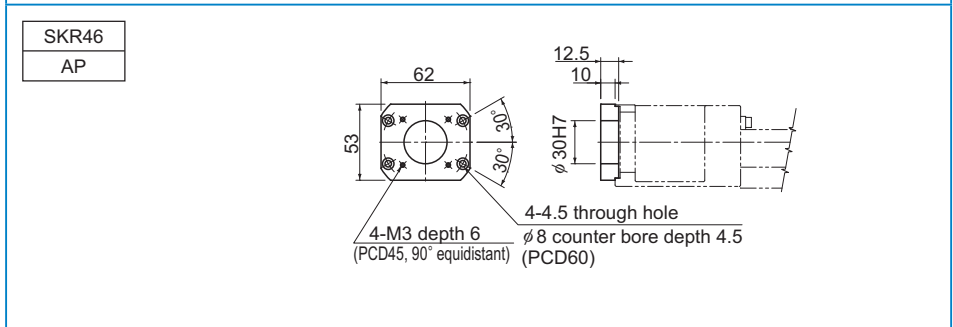
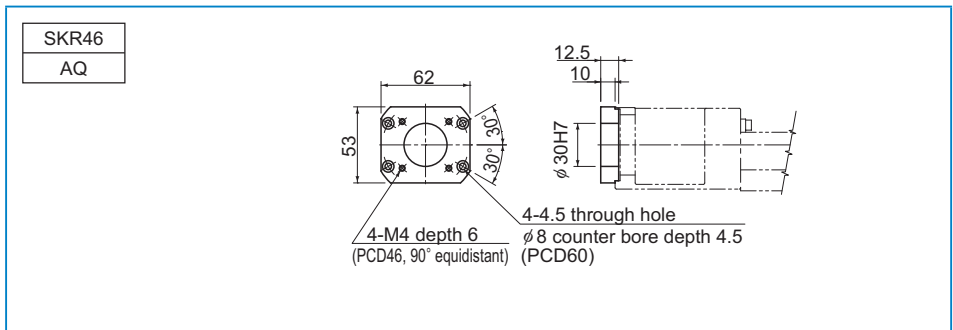

SKR46

AU

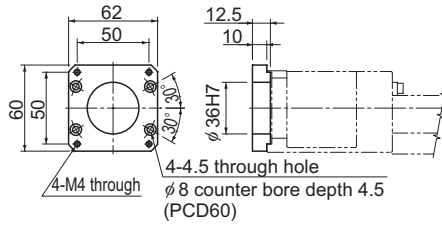

SKR46

AY

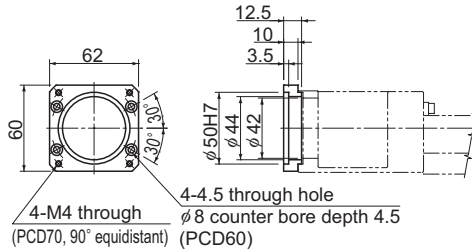

SKR46

AV

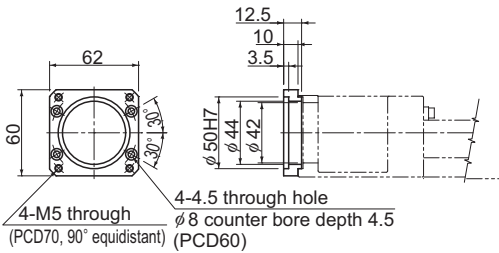

● For Model SKR55

SKR**	···· Actuator model number
●◇	····●: Housing A
	◇: Intermediate Flange

■ Housing A

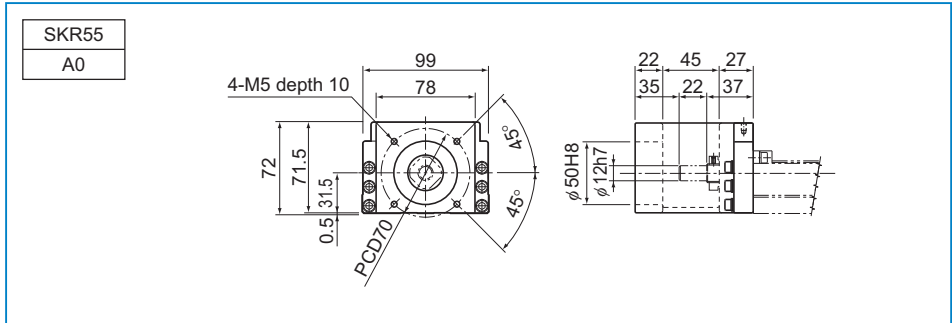

■ Turnaround Housing A

Note) Specify mounting holes when ordering.

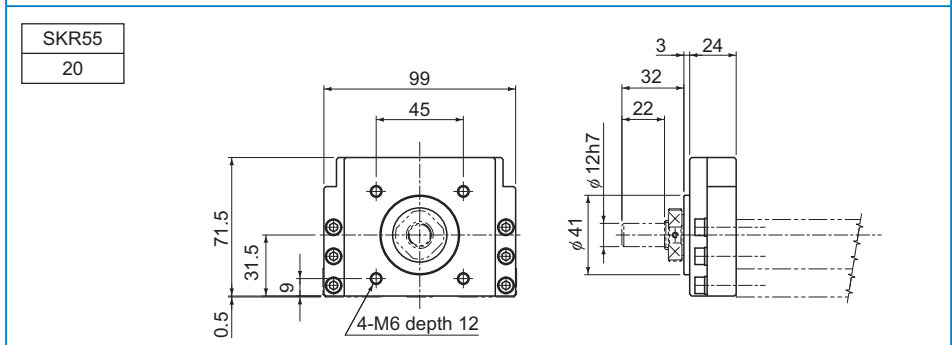
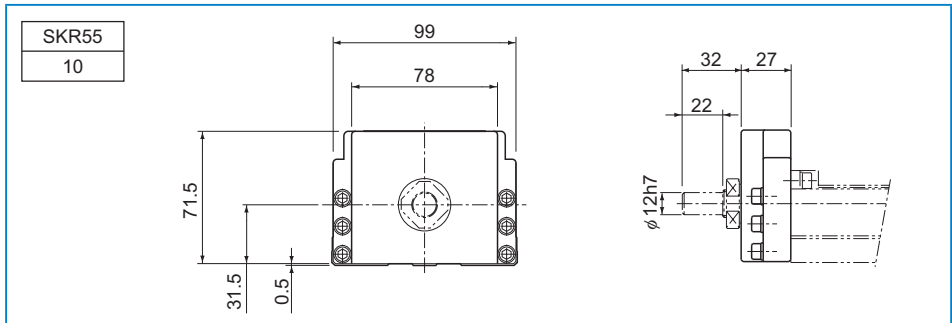

Intermediate Flange

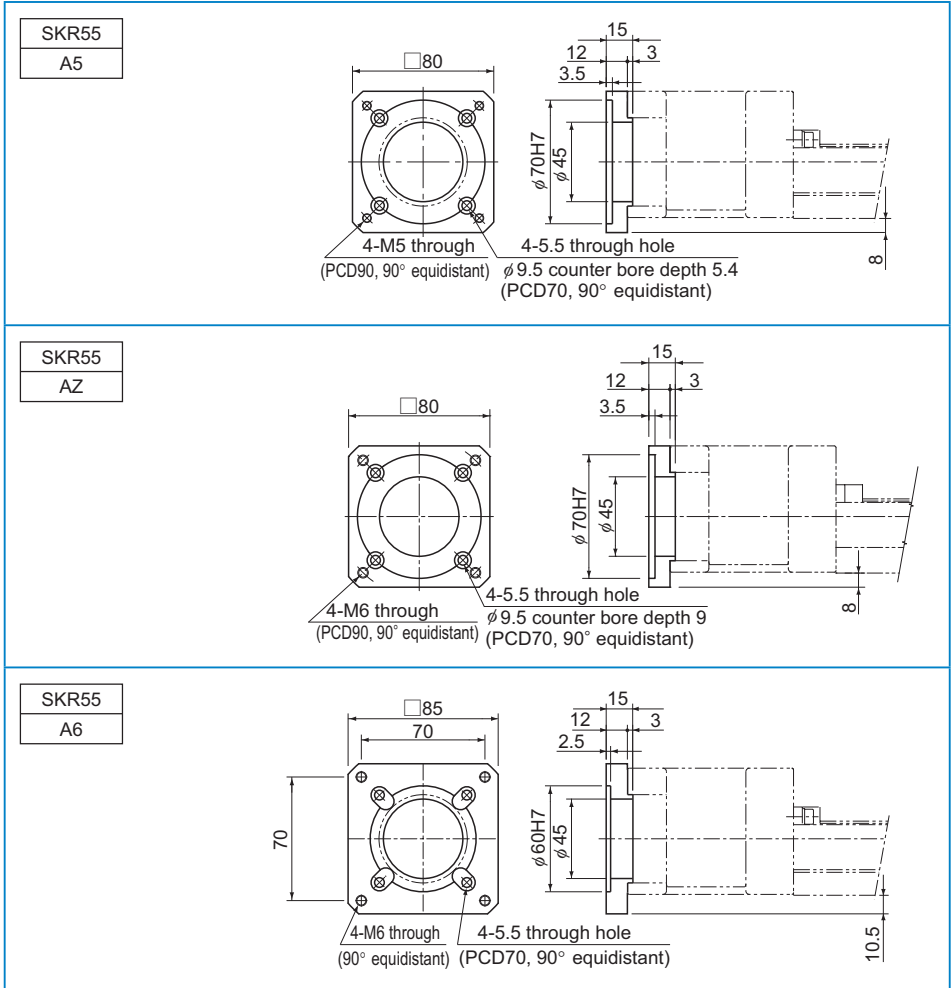

● For Model SKR65

SKR**	···· Actuator model number
●◇	····●: Housing A
	◇: Intermediate Flange

■ Housing A

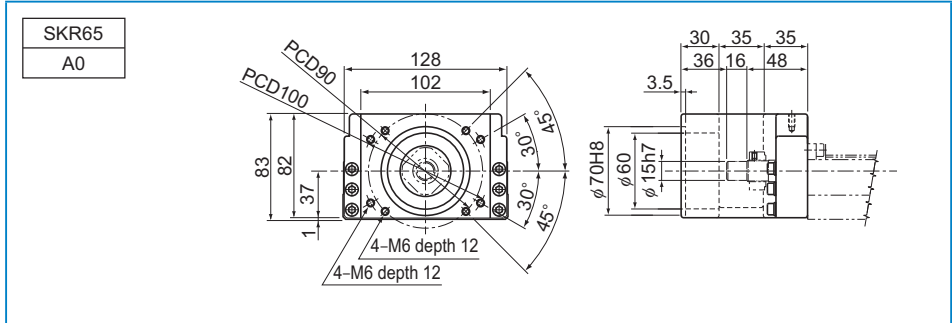

■ Turnaround Housing A

Note) Specify mounting holes when ordering.

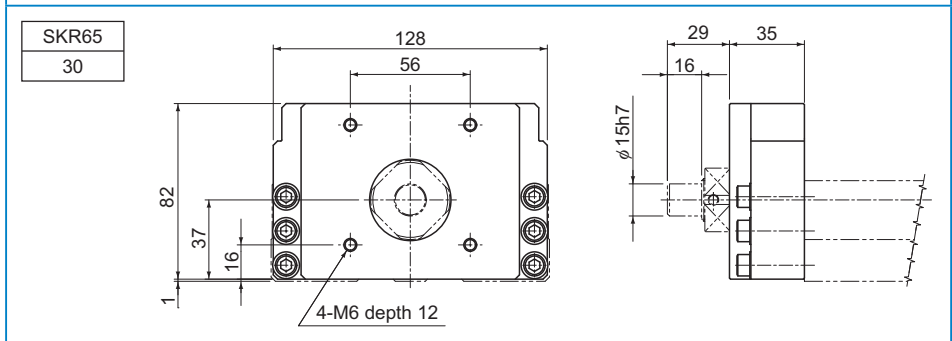
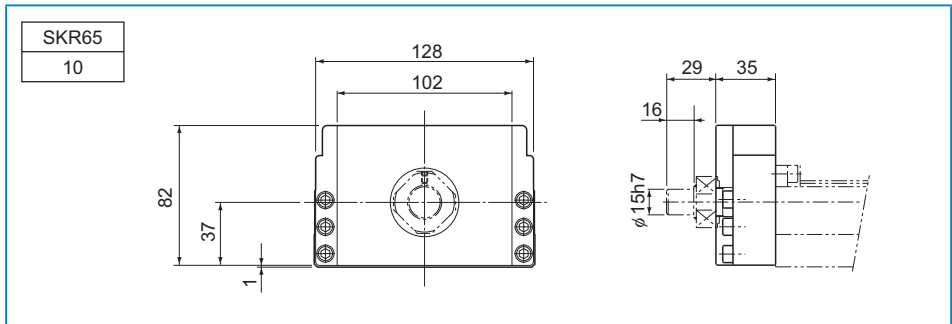

Intermediate Flange

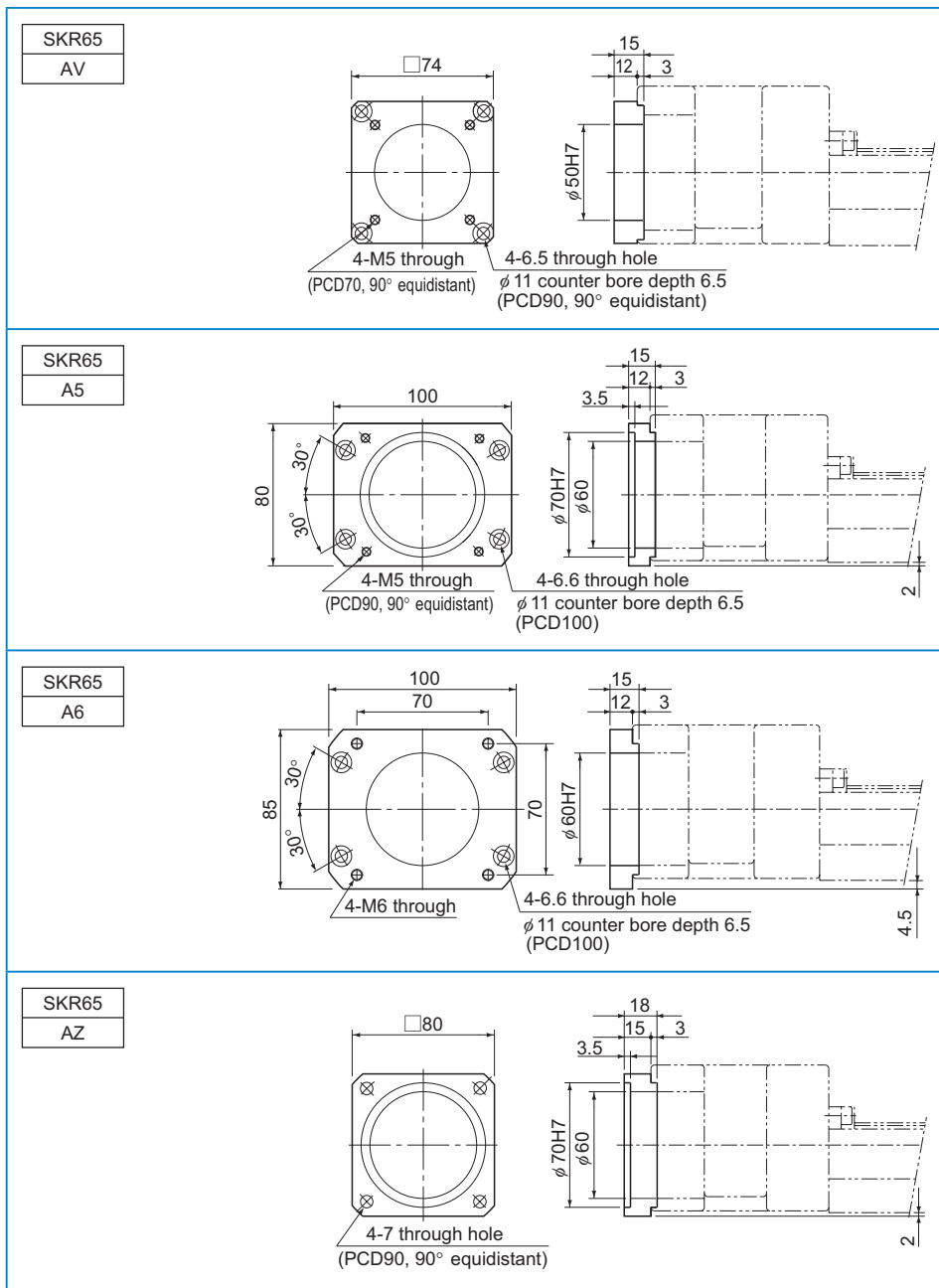

Motor Wrap Type

Model SKR is available in "Motor Wrap" types that allow the motor to be turned around in order to minimize the dimension in the longitudinal direction. (Pulley ratio: 1:1). Contact THK for details.

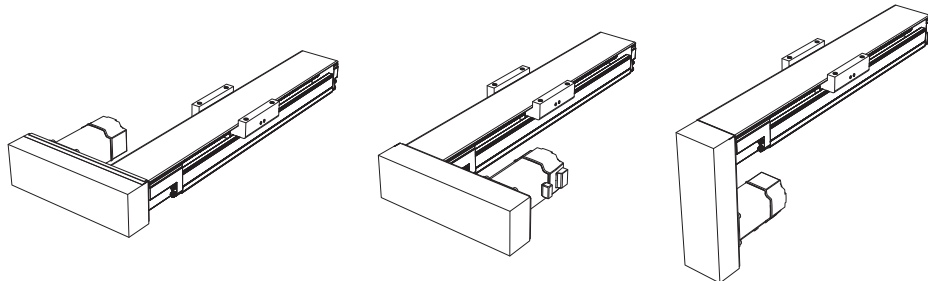

KR

LM Guide Actuator Model KR

LM Guide + Ball Screw = Integral-structure Actuator

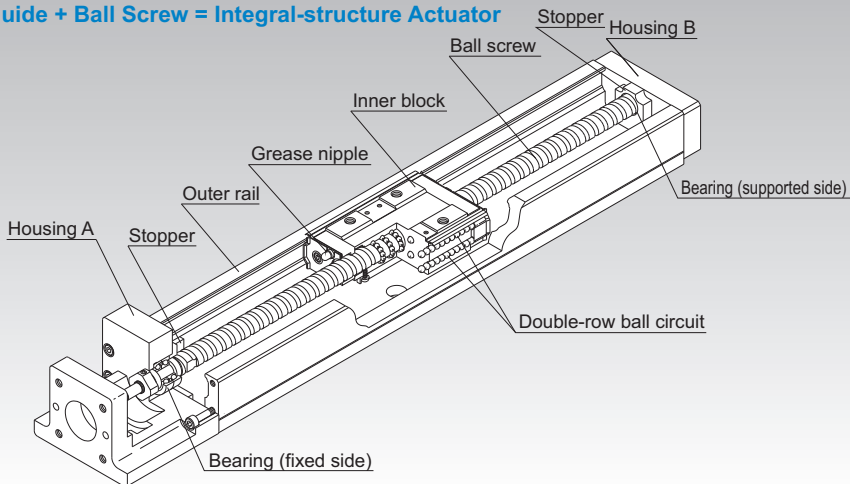

Fig.1 Structure of LM Guide Actuator Model KR

Structure and Features

Because of its integral-structure inner block consisting of a highly rigid outer rail with a U-shaped cross section, LM Guide units on both side faces and a Ball Screw unit in the center, LM Guide Actuator model KR achieves a highly rigid and highly accurate actuator in a minimal space.

In addition, since the housings A and B also serve as support units and the inner block as a table, this model allows significant reduction of man-hours required for design and assembly, thus contributing to total cost cutting.

[4-way Equal Load]

Each row of balls is arranged at a contact angle of 45° so that the rated load on the inner block is uniform under loads applied to the inner block in the four directions (radial, reverse radial and lateral directions). As a result, model KR can be used in any mounting orientation.

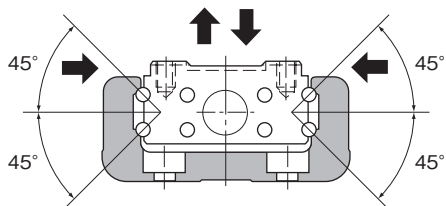

Fig.2 Load Capacity and Contact Angle of Model KR

[High Rigidity]

Use of an outer rail with a U-shaped cross section increases the rigidity against a moment and torsion.

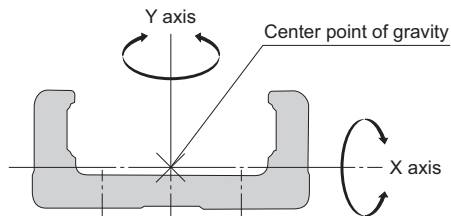

Fig.3 Cross Section of the Outer Rail

Table1 Cross-sectional Characteristics of the Outer rail Rail

Model No.	I_x [mm ⁴]	I_y [mm ⁴]	Mass[kg/m]
KR15	9.08×10^2	1.42×10^4	1.04
KR20	6.1×10^3	6.2×10^4	2.6
KR26	1.7×10^4	1.5×10^5	3.9
KR30H	2.7×10^4	2.8×10^5	5.0
KR33	6.2×10^4	3.8×10^5	6.6
KR45H	8.4×10^4	8.9×10^5	9.0
KR46	2.4×10^5	1.5×10^6	12.6
KR55	2.2×10^5	2.3×10^6	15.0
KR65	4.6×10^5	5.9×10^6	23.1

I_x =geometrical moment of inertia around X axis

I_y =geometrical moment of inertia around Y axis

[High Accuracy]

Since the linear guide section consists of 4 rows of circular-arc grooves that enable balls to smoothly move even under a preload, a highly rigid guide with no clearance is achieved. Additionally, variation in frictional resistance caused by load fluctuation is minimized, allowing the system to follow highly accurate feed.

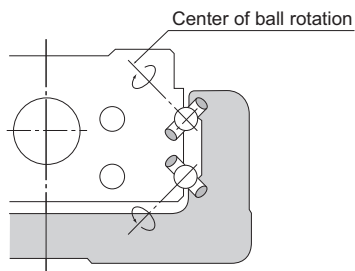

Fig.4 Contact Structure of Model KR

[Space Saving]

Use of a inner block integrating LM Guide units on both ends and a Ball Screw unit in the center makes model KR a highly rigid and highly accurate actuator in a minimal space.

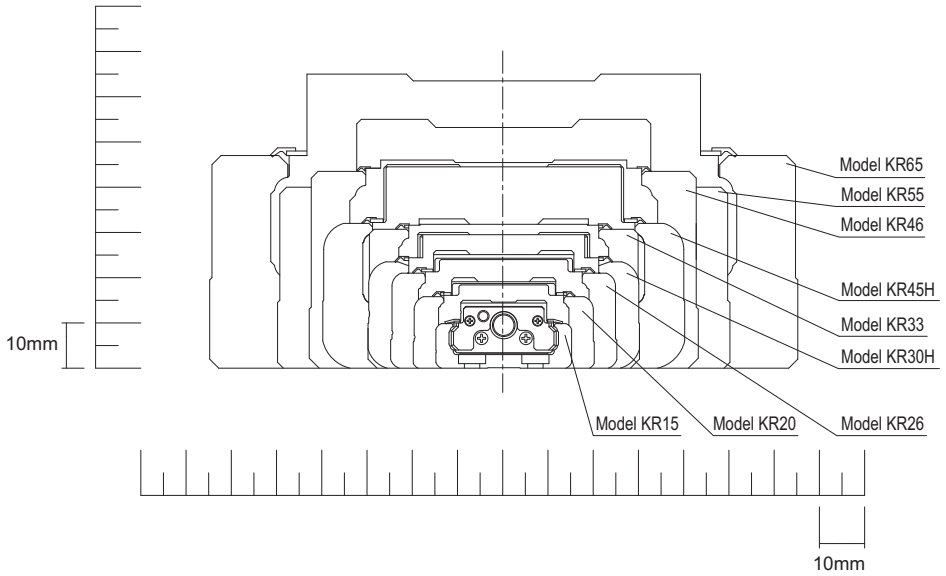

Fig.5 Cross Sectional Drawing

[Seal]

Model KR is equipped with end seals and side seals for dust prevention as standard.

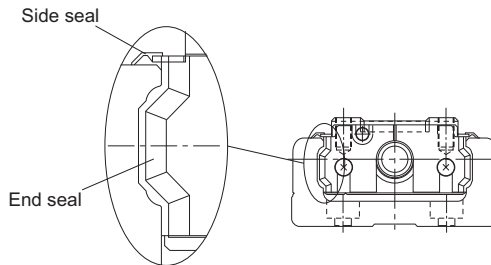

Table2 shows the rolling resistance and seal resistance per inner block (guide section).

Table2 Maximum Resistance Value Unit: N

Model No.	Rolling resistance value	Seal resistance value	Total
KR15	0.2	0.7	0.9
KR20	0.5	0.7	1.2
KR26	0.6	0.8	1.4
KR30H	1.5	2.0	3.5
KR33	1.5	1.9	3.4
KR45H	2.5	2.6	5.1
KR46	2.5	2.5	5
KR55	5.0	3.8	8.8
KR65	6.0	4.1	10.1

Note) The rolling resistance represents the value when a lubricant is not used.

Types and Features

Model KR-A (with a Single Long Type Block)

Representative model of KR.

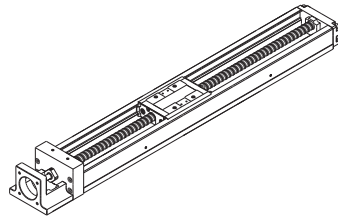

Model KR-A

Model KR-B (with Two Long Type Blocks)

Equipped with two units of the inner block of model KR-A, this model achieves higher rigidity and higher load carrying capacity.

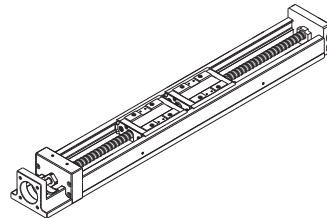

Model KR-B

Model KR-C (with a Single Short Type Block)

This model has a shorter overall length of the inner block and a longer stroke than model KR-A.

(Supported models: model KR30H, 33, 45H, 46)

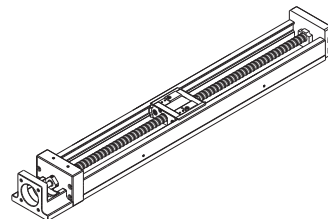

Model KR-C

Model KR-D (with Two Short Type Blocks)

Equipped with two units of the inner block of model KR-C, this design allows a span between blocks that suits the equipment, thus to achieve high rigidity.

(Supported models: model KR30H, 33, 45H, 46)

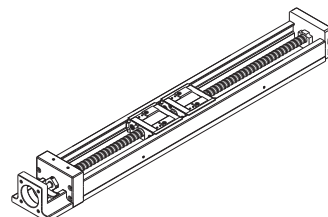

Model KR-D

Load Ratings in All Directions and Static Permissible Moment

[Load Rating]

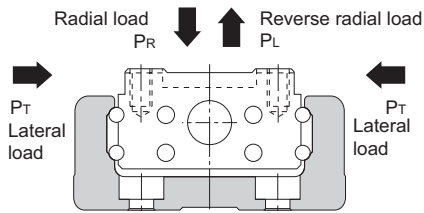

● LM Guide Unit

Model KR is capable of receiving loads in four directions (radial, reverse radial and lateral directions). Its basic load ratings are equal in all four directions (radial, reverse radial and lateral directions), and their values are indicated in Table3 on **A2-80** and **A2-81**.

● Ball Screw Unit

Since the inner block is incorporated with a ball screw nut, model KR is capable of receiving an axial load. The basic load rating value is indicated in Table3 on **A2-80** and **A2-81**.

● Bearing Unit (Fixed Side)

Since housing A contains an angular bearing, model KR is capable of receiving an axial load. The basic load rating value is indicated in Table3 on **A2-80** and **A2-81**.

[Equivalent Load (LM Guide Unit)]

The equivalent load when the LM Guide unit of model KR simultaneously receives loads in all directions is obtained from the following equation.

$$P_E = P_R (P_L) + P_T$$

P_E : Equivalent load (N)

: Radial direction

: Reverse radial direction

: Lateral direction

P_R : Radial load (N)

P_L : Reverse radial load (N)

P_T : Lateral load (N)

Table3 Load Rating of Model KR

Model No.			KR15		KR20		KR26		
			KR1501	KR1502	KR2001	KR2006	KR2602	KR2606	
LM guide unit	Basic dynamic load rating C (N)	Long type block	1930		3590		7240		
		Short type block	—		—		—		
	Basic static load rating C ₀ (N)	Long type block	3450		6300		12150		
		Short type block	—		—		—		
	Radial clearance (mm)	Normal grade, high accuracy grade	-0.001 to +0.002		-0.003 to +0.002		-0.004 to +0.002		
		Precision grade	-0.005 to -0.002		-0.007 to -0.003		-0.01 to -0.004		
Ball screw unit	Basic dynamic load rating C _a (N)	Normal grade, high accuracy grade	340	230	660	860	2350	1950	
		Precision grade	340	230	660	1060	2350	2390	
	Basic static load rating C _{0a} (N)	Normal grade, high accuracy grade	660	410	1170	1450	4020	3510	
		Precision grade	660	410	1170	1600	4020	3900	
	Screw shaft diameter (mm)		5		6		8		
	Lead (mm)		1	2	1	6	2	6	
	Thread minor diameter (mm)		4.5		5.3	5.0	6.6	6.7	
	Ball center-to-center diameter (mm)		5.15		6.15	6.3	8.3	8.4	
Bearing unit (Fixed side)	Axial direction	Basic dynamic load rating C _a (N)	590		1000		1380		
		Static permissible load P _{0a} (N)	290		1240		1760		

Note1) The load ratings in the LM Guide unit each indicate the load rating per inner block.

Note2) The Ball Screw of precision grade (grade P) for models KR30H, KR33, KR45H10 and KR4610 is incorporated with spacer balls in the proportion of one to one.

Note3) The Ball Screw of precision grade (grade P) for models KR45H20, KR4620, KR55 and KR65 is incorporated with spacer balls in the proportion of two to one.

	KR30H		KR33		KR45H		KR46		KR55	KR65
	KR30H06	KR30H10	KR3306	KR3310	KR45H10	KR45H20	KR4610	KR4620		
	11600		11600		23300		27400		38100	50900
	4900		4900		11900		14000		—	—
	20200		20200		39200		45500		61900	80900
	10000		10000		19600		22700		—	—
	-0.004 to +0.002		-0.004 to +0.002		-0.006 to +0.003		-0.006 to +0.003		-0.007 to +0.004	-0.008 to +0.004
	-0.012 to -0.004		-0.012 to -0.004		-0.016 to -0.006		-0.016 to -0.006		-0.019 to -0.007	-0.022 to -0.008
	2840	1760	2840	1760	3140	3040	3140	3040	3620	5680
	2250	1370	2250	1370	2940	3430	2940	3430	3980	5950
	4900	2840	4900	2840	6760	7150	6760	7150	9290	14500
	2740	1570	2740	1570	3720	5290	3720	5290	6850	10700
	10		10		15		15		20	25
	6	10	6	10	10	20	10	20	20	25
	7.8		7.8		12.5		12.5		17.5	22
	10.5		10.5		15.75		15.75		20.75	26
	1790		1790		6660		6660		7600	13700
	2590		2590		3240		3240		3990	5830

[Static Permissible Moment (LM Guide Unit)]

The Inner block is capable of receiving moment loads in all three (3) directions.

Table 4 on **A2-83** shows static permissible moments in the M_A , M_B and M_C directions.

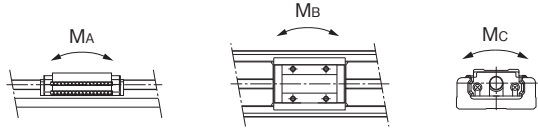
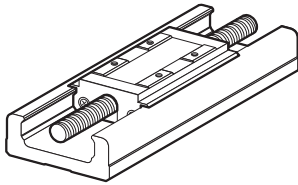

With a single long type block (Model KR-A)

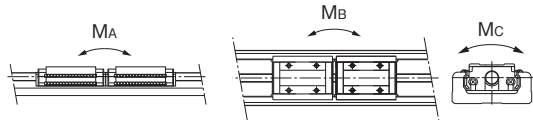
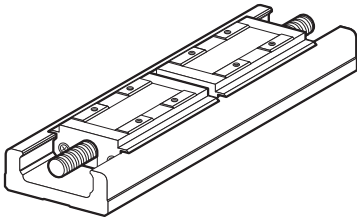

With double long type blocks (Model KR-B)

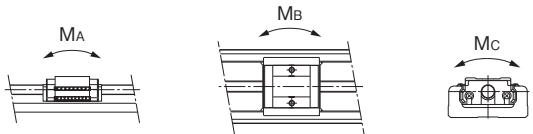
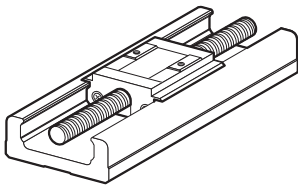

With a single short type block (Model KR-C)

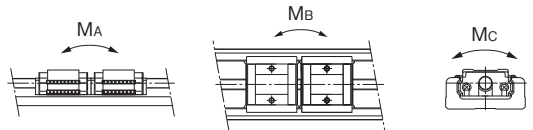
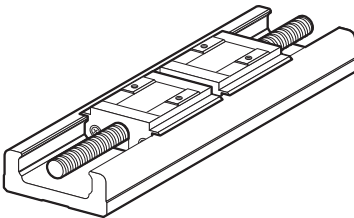

With double short type blocks (Model KR-D)

Table4 Static Permissible Moments of Model KR

Unit: N-m

Model No.	Static permissible moment		
	M _A	M _B	M _C
KR15-A	12.1	12.1	38
KR15-B	70.3	70.3	76
KR20-A	31	31	83
KR20-B	176	176	165
KR26-A	84	84	208
KR26-B	480	480	416
KR30H-A	166	166	428
KR30H-B	908	908	857
KR30H-C	44	44	214
KR30H-D	319	319	427
KR33-A	166	166	428
KR33-B	908	908	857
KR33-C	44	44	214
KR33-D	319	319	427
KR45H-A	486	486	925
KR45H-B	2732	2732	1850
KR45H-C	130	130	463
KR45H-D	994	994	925
KR46-A	547	547	1400
KR46-B	2940	2940	2800
KR46-C	149	149	700
KR46-D	1010	1010	1400
KR55-A	870	870	2280
KR55-B	4890	4890	4570
KR65-A	1300	1300	3920
KR65-B	7230	7230	7840

Note1) Symbols A, B, C or D in the end of each model number indicates the inner block size and the number of inner blocks used.

A: With a single long type block

B: With double long type blocks

C: With a single short type block

D: With double short type blocks

Note2) The values for models KR-B/D indicate the values when double inner blocks are used in close contact with each other.

Note3) Static permissible moment is the maximum moment that can be permitted while the product is stationary.

Maximum Speeds with Different Strokes

Table5 Maximum speed

Model No.	Ball Screw lead (mm)	Stroke* (mm)		Outer rail length (mm)	Maximum speed (mm/s)					
		Long type block	Short type block		Precision grade	High accuracy grade	Normal grade	Precision grade	High accuracy grade	Normal grade
					Long type block			Short type block		
KR15	01	25	—	75	100	100	—	—	—	—
		50	—	100	100	100	—	—	—	—
		75	—	125	100	100	—	—	—	—
		100	—	150	100	100	—	—	—	—
		125	—	175	100	100	—	—	—	—
	02	150	—	200	100	100	—	—	—	—
		25	—	75	200	200	—	—	—	—
		50	—	100	200	200	—	—	—	—
		75	—	125	200	200	—	—	—	—
		100	—	150	200	200	—	—	—	—
KR20	01	125	—	175	200	200	—	—	—	—
		150	—	200	200	200	—	—	—	—
		30	—	100	100	100	—	—	—	—
	06	80	—	150	100	100	—	—	—	—
		130	—	200	100	100	—	—	—	—
KR26	02	30	—	100	600	600	—	—	—	—
		80	—	150	600	600	—	—	—	—
		130	—	200	600	600	—	—	—	—
	06	60	—	150	200	200	—	—	—	—
		110	—	200	200	200	—	—	—	—
		160	—	250	200	200	—	—	—	—
		210	—	300	200	200	—	—	—	—
KR30H	06	60	—	150	600	590	—	—	—	—
		110	—	200	600	590	—	—	—	—
		160	—	250	600	590	—	—	—	—
		210	—	300	600	590	—	—	—	—
		50	70	150	600	470	600	470	600	470
	10	100	120	200	600	470	600	600	470	470
		200	220	300	600	470	600	600	470	470
		300	320	400	600	470	600	600	470	470
		400	420	500	590	470	530	470	530	470
		500	520	600	390	390	360	360	360	360
KR33	06	50	70	150	1000	790	1000	1000	790	790
		100	120	200	1000	790	1000	1000	790	790
		200	220	300	1000	790	1000	1000	790	790
		300	320	400	1000	790	1000	1000	790	790
		400	420	500	980	790	880	790	880	790
		500	520	600	650	650	600	600	600	600
	10	50	75	150	600	470	600	600	470	470
		100	125	200	600	470	600	600	470	470
		200	225	300	600	470	600	600	470	470
		300	325	400	600	470	600	600	470	470
KR33	06	400	425	500	590	470	530	470	470	
		500	525	600	390	390	360	360	360	360
		600	625	700	280	280	260	260	260	260
		50	75	150	1000	790	1000	1000	790	790
	10	100	125	200	1000	790	1000	1000	790	790
		200	225	300	1000	790	1000	1000	790	790
		300	325	400	1000	790	1000	1000	790	790
		400	425	500	980	790	880	790	880	790
KR33	10	500	525	600	650	650	600	600	600	600
		600	625	700	470	470	430	430	430	430

Model No.	Ball Screw lead (mm)	Stroke* (mm)		Outer rail length (mm)	Maximum speed (mm/s)					
					Precision grade	High accuracy grade	Normal grade	Precision grade	High accuracy grade	Normal grade
		Long type block	Short type block		Long type block			Short type block		
KR45H	10	200	230	340	740	520	740	520	740	520
		300	330	440	740	520	740	520	740	520
		400	430	540	740	520	740	520	740	520
		500	530	640	740	520	740	520	740	520
		600	630	740	730	520	640	520	640	520
		700	730	840	—	520	—	490	—	490
		800	830	940	—	430	—	380	—	380
	20	200	230	340	1480	1050	1480	1050	1480	1050
		300	330	440	1480	1050	1480	1050	1480	1050
		400	430	540	1480	1050	1480	1050	1480	1050
		500	530	640	1480	1050	1480	1050	1480	1050
		600	630	740	1430	1050	1280	1050	1280	1050
		700	730	840	—	1050	—	980	—	980
		800	830	940	—	840	—	770	—	770
KR46	10	190	220	340	740	520	740	520	740	520
		290	320	440	740	520	740	520	740	520
		390	420	540	740	520	740	520	740	520
		490	520	640	740	520	740	520	740	520
		590	620	740	730	520	650	520	650	520
		690	720	840	—	520	—	490	—	490
		790	820	940	—	430	—	390	—	390
	20	190	220	340	1480	1050	1480	1050	1480	1050
		290	320	440	1480	1050	1480	1050	1480	1050
		390	420	540	1480	1050	1480	1050	1480	1050
		490	520	640	1480	1050	1480	1050	1480	1050
		590	620	740	1440	1050	1300	1050	1300	1050
		690	720	840	—	1050	—	990	—	990
		790	820	940	—	850	—	780	—	780
KR55	20	800	—	980	1120	800	—	—	—	—
		900	—	1080	900	800	—	—	—	—
		1000	—	1180	740	740	—	—	—	—
		1100	—	1280	—	620	—	—	—	—
		1200	—	1380	—	530	—	—	—	—
KR65	25	790	—	980	1120	800	—	—	—	—
		990	—	1180	1120	800	—	—	—	—
		1190	—	1380	840	800	—	—	—	—
		1490	—	1680	—	550	—	—	—	—

*Indicates a stroke when one inner block is incorporated.

Note1) The maximum speed is restricted by the permissible rotation speed of the ball screw, the permissible speed of the guide or 6,000 min⁻¹ of motor speed.

Note2) If you are considering using this product at the maximum travel speed of Table5 or faster, contact THK.

Lubrication

Table6 shows standard greases used in model KR and grease nipple types.

Table6 Types of standard grease and grease nipples used

Model No.	Standard grease	Grease nipple used
KR15	THK AFF Grease	—
KR20	THK AFA Grease	PB107
KR26	THK AFA Grease	PB107
KR30H	THK AFB-LF Grease	PB107
KR33	THK AFB-LF Grease	PB107
KR45H	THK AFB-LF Grease	A-M6F
KR46	THK AFB-LF Grease	A-M6F
KR55	THK AFB-LF Grease	A-M6F
KR65	THK AFB-LF Grease	A-M6F

Static Safety Factor

LM Guide Actuator Model KR consists of an LM Guide, a Ball Screw and a support bearing. The static safety factor and the service life of each component can be obtained from the basic load rating indicated in "Rated load of model KR" (see Table3 on **A2-80**).

[Calculating the Static Safety Factor]

● LM Guide Unit

To calculate a load applied to the LM Guide of model KR, the average load required for calculating the service life and the maximum load needed for calculating the static safety factor must be obtained first. In particular, if the system starts and stops frequently, or if a large moment caused by an overhung load is applied to the system, it may receive an unexpectedly large load.

When selecting a model number, make sure that the desired model is capable of receiving the required maximum load (whether stationary or in motion).

$$f_s = \frac{C_0}{P_{\max}}$$

- f_s : Static safety factor
 C_0 : Basic static load rating (N)
 P_{\max} : Maximum applied load (N)

*The basic static load rating is a static load with a constant direction and magnitude whereby the sum of the permanent deformation of the rolling element and that of the raceway on the contact area under the maximum stress is 0.0001 times the rolling element diameter.

● Ball Screw Unit/Bearing Unit(Fixed Side)

If an unexpected external force is applied in the axial direction as a result of an inertia caused by an impact or start and stop while model KR is stationary or operating, it is necessary to take into account the static safety factor.

$$f_s = \frac{C_{0a}}{F_{\max}}$$

- f_s : Static safety factor
 C_{0a} : Basic static load rating (N)
 F_{\max} : Maximum applied load (N)

[Standard Values for the Static Safety Factor (f_s)]

Machine type	Load conditions	Minimum Static Safety Factor (f_s)
General industrial machinery	Without vibration or impact	1.0 to 3.5
	With vibration or impact	2.0 to 5.0

*The standard value of the static safety factor may vary depending on the load conditions as well as environment, lubrication status, mounting accuracy, and/or rigidity.

Service Life

[LM Guide Unit]

● Nominal Life

$$L = \left(\frac{f_c \cdot C}{f_w \cdot P_c} \right)^3 \times 50$$

- L : Nominal life (km)
 (The total travel distance that 90% of a group of identical LM Guide units independently operating under the same conditions can achieve without showing flaking)
- C : Basic dynamic load rating (N)
- P_c : Calculated applied load (N)
- f_w : Load factor (see Table8 on **A2-90**)
- f_c : Contact factor (see Table7 on **A2-90**)

- If a moment is applied to model KR-A/C or model KR-B/D using two inner blocks in close contact with each other, calculate the equivalent load by multiplying the applied moment by the equivalent factor indicated in Table9 on **A2-90**.

$$P_m = K \cdot M$$

- P_m : Equivalent load (per inner block) (N)
- K : Equivalent moment factor (see Table9 on **A2-90**)
- M : Applied moment (N-mm)
 (If planning to use the product with a wide inner block span, contact THK.)
- If moment M_c is applied to model KR-B/D

$$P_m = \frac{K_c \cdot M_c}{2}$$

- If a radial load (P) and a moment are simultaneously applied to model KR

$$P_E = P_m + P$$

- P_E : Total equivalent radial load (N)
 Perform a nominal life calculation using the above data.

● Service Life Time

When the nominal life (L) has been obtained, the service life time is obtained using the following equation (if the stroke length and the number of reciprocations per minute are constant).

$$L_h = \frac{L \times 10^6}{2 \cdot \ell_s \cdot n_1 \times 60}$$

L_h : Service life time (h)

ℓ_s : Stroke length (mm)

n_1 : Number of reciprocations per minute (min^{-1})

[Ball Screw Unit/Bearing Unit(Fixed Side)]

● Nominal Life

$$L = \left(\frac{C_a}{f_w \cdot F_a} \right)^3 \times 10^6$$

L : Nominal life (rev)

(The total number of revolutions that 90% of a group of identical Ball Screw units independently operating under the same conditions can achieve without showing flaking)

C_a : Basic dynamic load rating (N)

F_a : Applied load (N)

f_w : Load factor (see Table8 on **A2-90**)

● Service Life Time

When the nominal life (L) has been obtained, the service life time is obtained using the following equation (if the stroke length and the number of reciprocations per minute are constant).

$$L_h = \frac{L \cdot \ell}{2 \cdot \ell_s \cdot n_1 \times 60}$$

L_h : Service life time (h)

ℓ_s : Stroke length (mm)

n_1 : Number of reciprocations per minute (min^{-1})

ℓ : Ball Screw lead (mm)

■ f_c : Contact Factor

If two inner blocks are used in close contact with each other with model KR-B/D, multiply the basic load rating by the corresponding contact factor indicated in Table7.

Table7 Contact Factor (f_c)

Inner block types	Contact factor f_c
Model KR-B Model KR-D	0.81

■ f_w : Load Factor

Table8 shows load factors.

Table8 Load Factor (f_w)

Vibrations/impact	Speed(V)	f_w
Faint	Very low $V \leq 0.25\text{m/s}$	1 to 1.2
Weak	Slow $0.25 < V \leq 1\text{m/s}$	1.2 to 1.5
Medium	Medium $1 < V \leq 2\text{m/s}$	1.5 to 2
Strong	High $V > 2\text{m/s}$	2 to 3.5

■ K : Moment Equivalent Factor (LM Guide Unit)

When model KR travels under a moment, the distribution of load applied to the LM Guide is locally large (see **A 1-40**). In such cases, calculate the load by multiplying the moment value by the corresponding moment equivalent factor indicated in Table9.

Symbols K_A , K_B and K_C indicate the moment equivalent loads in the M_A , M_B and M_C directions, respectively.

Table9 Equivalent moment factor(K)

Model No.	K_A	K_B	K_C
KR15-A	3.2×10^{-1}	3.2×10^{-1}	9.09×10^{-2}
KR15-B	5.96×10^{-2}	5.96×10^{-2}	9.09×10^{-2}
KR20-A	2.4×10^{-1}	2.4×10^{-1}	7.69×10^{-2}
KR20-B	4.26×10^{-2}	4.26×10^{-2}	7.69×10^{-2}
KR26-A	1.73×10^{-1}	1.73×10^{-1}	5.88×10^{-2}
KR26-B	3.06×10^{-2}	3.06×10^{-2}	5.88×10^{-2}
KR30H-A	1.51×10^{-1}	1.51×10^{-1}	4.78×10^{-2}
KR30H-B	2.76×10^{-2}	2.76×10^{-2}	4.78×10^{-2}
KR30H-C	2.77×10^{-1}	2.77×10^{-1}	4.78×10^{-2}
KR30H-D	3.99×10^{-2}	3.99×10^{-2}	4.78×10^{-2}
KR33-A	1.51×10^{-1}	1.51×10^{-1}	4.93×10^{-2}
KR33-B	2.57×10^{-2}	2.57×10^{-2}	4.93×10^{-2}
KR33-C	2.77×10^{-1}	2.77×10^{-1}	4.93×10^{-2}
KR33-D	3.55×10^{-2}	3.55×10^{-2}	4.93×10^{-2}
KR45H-A	9.83×10^{-2}	9.83×10^{-2}	3.45×10^{-2}
KR45H-B	1.87×10^{-2}	1.87×10^{-2}	3.45×10^{-2}
KR45H-C	1.83×10^{-1}	1.83×10^{-1}	3.45×10^{-2}
KR45H-D	2.81×10^{-2}	2.81×10^{-2}	3.45×10^{-2}
KR46-A	1.01×10^{-1}	1.01×10^{-1}	3.38×10^{-2}
KR46-B	1.78×10^{-2}	1.78×10^{-2}	3.38×10^{-2}
KR46-C	1.85×10^{-1}	1.85×10^{-1}	3.38×10^{-2}
KR46-D	2.5×10^{-2}	2.5×10^{-2}	3.38×10^{-2}
KR55-A	8.63×10^{-2}	8.63×10^{-2}	2.83×10^{-2}
KR55-B	1.53×10^{-2}	1.53×10^{-2}	2.83×10^{-2}
KR65-A	7.55×10^{-2}	7.55×10^{-2}	2.14×10^{-2}
KR65-B	1.35×10^{-2}	1.35×10^{-2}	2.14×10^{-2}

Note) The values for models KR-B/D indicate the values when double inner blocks are used in close contact with each other.

Accuracy Standards

The accuracy standard of model KR is defined in positioning repeatability, positioning accuracy, running parallelism (vertical direction) and backlash.

[Positioning Repeatability]

Command the position to a given arbitrary point. Measure the position and repeat seven times from the same direction. Record the difference between the largest and smallest values. Conduct the same test at three points: the middle of the stroke, and at both the approximate maximum and minimum positions of travel. Express the maximum difference value of the three measurements divided by 2 with a “±” sign.

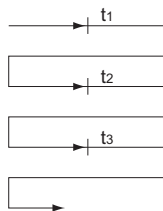

Fig.6 Positioning Repeatability

[Positioning Accuracy]

Using the maximum stroke as the reference length, express the maximum error between the actual distance traveled from the reference point and the command value in an absolute value as positioning accuracy.

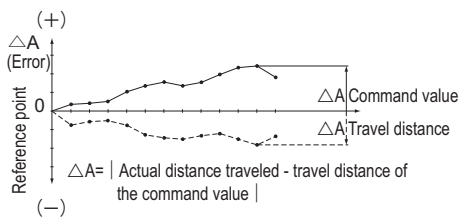

Fig.7 Positioning Accuracy

[Running of Parallelism (Vertical direction)]

Place a straightedge on the surface table where model KR is mounted, measure almost throughout the travel distance of the inner block using a test indicator. Use the maximum difference among the readings within the travel distance as the running parallelism measurement.

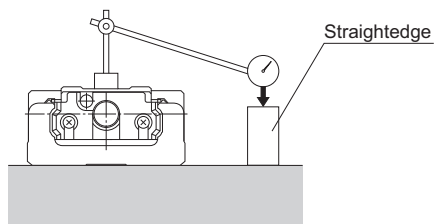

Fig.8 Running of Parallelism

[Backlash]

Feed and slightly move the inner block and read the measurement on the test indicator as the reference value. Subsequently, apply a load to the inner block from the same direction (table feed direction), and then release the inner block from the load. Use the difference between the reference value and the return as the backlash measurement.

Perform this measurement in the center and near both ends, and use the maximum value as the measurement value.

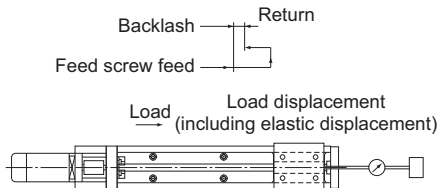

Fig.9 Backlash

The accuracies of model KR are classified into normal grade (no symbol), high accuracy grade (H) and precision grade (P). Tables below show standards for all the accuracies.

Table10 Normal Grade (No Symbol)

Unit: mm

Model No.	Stroke*	Outer rail length	Positioning Repeatability	Positioning Accuracy	Running Parallelism (Vertical Direction)	Backlash	Starting torque (N-cm)
KR20	30	100	±0.01	No standard defined	No standard defined	0.02	0.5
	80	150					
	130	200					
KR26	60	150	±0.01	No standard defined	No standard defined	0.02	1.5
	110	200					
	160	250					
KR30H	210	300	±0.01	No standard defined	No standard defined	0.02	7
	50	150					
	100	200					
	200	300					
	300	400					
KR33	400	500	±0.01	No standard defined	No standard defined	0.02	7
	500	600					
	600	700					
	200	300					
	300	400					
	400	500					
KR45H	500	600	±0.01	No standard defined	No standard defined	0.02	10
	600	740					
	700	840					
	800	940					
	200	340					
	300	440					
KR46	400	540	±0.01	No standard defined	No standard defined	0.02	10
	590	740					
	690	840					
	790	940					
	190	340					
	290	440					
KR55	390	540	±0.01	No standard defined	No standard defined	0.05	12
	490	640					
	590	740					
	690	840					
	790	940					
KR65	800	980	±0.01	No standard defined	No standard defined	0.05	12
	900	1080					
	1000	1180					
	1100	1280					
	1200	1380					
KR65	790	980	±0.012	No standard defined	No standard defined	0.05	15
	990	1180					
	1190	1380					

*Indicates stroke length when one long-type inner block is incorporated.

Note1) The evaluation method complies with THK standards.

Note2) Measurements are taken while using a motor provided by THK. For motor-wrap configuration, these values may not apply.

Note3) The starting torque represents the value when THK AFB-LF Grease is used.

However, that of models KR20 and KR26 represents the value when THK AFA Grease is used, and that of KR15 represents the value when THK AFF Grease is used.

Note4) If highly viscous grease such as vacuum grease and clean room grease is used, the actual starting torque may exceed the corresponding value in the table. Use much care in selecting a motor.

Note5) Contact THK for accuracy information of units longer than the standard length.

Note6) Model KR15 is available in high accuracy grade (H) and precision grade (P) only.

Table11 High Accuracy Grade (H)

Unit: mm

Model No.	Stroke*	Outer rail length	Positioning accuracy repeatability	Positioning Accuracy	Running of Parallelism (Vertical direction)	Backlash	Starting torque (N-cm)
KR15	25	75	±0.004	0.04	0.02	0.01	0.4
	50	100					
	75	125					
	100	150					
	125	175					
	150	200					
KR20	30	100	±0.005	0.06	0.025	0.01	0.5
	80	150					
	130	200					
KR26	60	150	±0.005	0.06	0.025	0.01	1.5
	110	200					
	160	250					
	210	300					
KR30H	50	150	±0.005	0.06	0.025	0.02	7
	100	200		0.10			
	200	300					
	300	400		0.035			
	400	500					
	500	600					
KR33	50	150	±0.005	0.06	0.025	0.02	7
	100	200		0.10			
	200	300					
	300	400		0.035			
	400	500					
	500	600					
KR45H	200	340	±0.005	0.10	0.035	0.02	10
	300	440		0.12			
	400	540					
	500	640		0.15			
	600	740					
	700	840					
	800	940					
KR46	190	340	±0.005	0.10	0.035	0.02	10
	290	440		0.12			
	390	540					
	490	640		0.15			
	590	740					
	690	840					
KR55	790	940	±0.005	0.18	0.05	0.05	12
	800	980		0.25			
	900	1080					
	1000	1180					
KR65	1100	1280	±0.008	0.18	0.05	0.05	12
	1190	1380		0.20			
	1200	1380					
	1490	1680		0.28			

*Indicates stroke length when one long-type inner block is incorporated.

Table12 Precision Grade (P)

Unit: mm

Model No.	Stroke*	Outer rail length	Positioning accuracy repeatability	Positioning Accuracy	Running of Parallelism (Vertical direction)	Backlash	Starting torque (N-cm)			
KR15	25	75	±0.003	0.02	0.01	0.002	0.8			
	50	100								
	75	125								
	100	150								
	125	175								
KR20	150	200	±0.003	0.02	0.01	0.003	1.2			
	30	100								
	80	150								
KR26	130	200	±0.003	0.02	0.01	0.003	4			
	60	150								
	110	200								
	160	250								
KR30H	210	300	±0.003	0.02	0.01	0.003	15			
	50	150								
	100	200								
	200	300		0.025	0.015					
	300	400								
	400	500								
KR33	500	600	±0.003	0.02	0.01	0.003	15			
	50	150								
	100	200								
	200	300		0.025	0.015					
	300	400								
	400	500								
KR45H	500	600	±0.003	0.025	0.015	0.003	15			
	600	700								
	200	340					0.03	0.02	17	
	300	440								
	400	540								
KR46	500	640	±0.003	0.025	0.015	0.003	15			
	600	740								
	190	340						0.03	0.02	
	290	440								
	390	540								
	KR55	490		640	±0.005		0.035	0.025	0.003	17
		590		740						
690		840								
790		940	0.035	0.025						
800		980								
KR65	900	1080	±0.005	0.035	0.025	0.005	20			
	1000	1180								
	790	980		0.04	0.03		22			
990	1180									
	1190	1380								

*Indicates stroke length when one long-type inner block is incorporated.

Note1) The evaluation method complies with THK standards.

Note2) Measurements are taken while using a motor provided by THK. For motor-wrap configuration, these values may not apply.

Note3) The starting torque represents the value when THK AFB-LF Grease is used.

However, that of models KR20 and KR26 represents the value when THK AFA Grease is used, and that of KR15 represents the value when THK AFF Grease is used.

Note4) If highly viscous grease such as vacuum grease and clean room grease is used, the actual starting torque may exceed the corresponding value in the table. Use much care in selecting a motor.

Note5) Contact THK for accuracy information of units longer than the standard length.

Model Number Coding

Model No.	Ball Screw Lead	Inner block type	Stroke	Accuracy
KR33	10	A	0200	P
①	②	③	④	⑤
KR15	01 : 1mm	A	0025 : 25mm	No symbol: normal grade
KR20	02 : 2mm	B	0050 : 50mm	H : High accuracy grade
KR26	06 : 6mm	C	∩	P : Precision Grade
KR30H	10 : 10mm	D	1490 : 1490mm	
KR33	20 : 20mm			
KR45H	25 : 25mm			
KR46				
KR55				
KR65				

If "2" (with Bellows) was selected for the cover ⑦, specify a stroke incorporating the bellows (→ **A2-125**).

The available ball screw leads differ depending on the model.

KR15 : "01", "02"
 KR20 : "01", "06"
 KR26 : "02", "06"
 KR30H : "06", "10"
 KR33 : "06", "10"
 KR45H : "10", "20"
 KR46 : "10", "20"
 KR55 : "20"
 KR65 : "25"

With/without a motor	Cover	Sensor	Housing A/ Intermediate Flange																																				
0	1	B	AQ																																				
⑥	⑦	⑧	⑨																																				
<table border="1"> <tr><td>0: direct-coupled (without a motor)</td></tr> <tr><td>1: direct-coupled (with a motor, specified by the customer)</td></tr> </table>	0: direct-coupled (without a motor)	1: direct-coupled (with a motor, specified by the customer)	<table border="1"> <tr><td>0: without a cover</td></tr> <tr><td>1: with a cover</td></tr> <tr><td>2: with a bellows</td></tr> </table>	0: without a cover	1: with a cover	2: with a bellows	<table border="1"> <tr><td>0: none</td></tr> <tr><td>1</td></tr> <tr><td>2</td></tr> <tr><td>6</td></tr> <tr><td>7</td></tr> <tr><td>B</td></tr> <tr><td>E</td></tr> <tr><td>H</td></tr> <tr><td>L</td></tr> <tr><td>J</td></tr> <tr><td>M</td></tr> </table>	0: none	1	2	6	7	B	E	H	L	J	M	<table border="1"> <tr><td>10</td></tr> <tr><td>20</td></tr> <tr><td>30</td></tr> <tr><td>40</td></tr> <tr><td>50</td></tr> <tr><td>60</td></tr> <tr><td>A0</td></tr> <tr><td>A5</td></tr> <tr><td>A6</td></tr> <tr><td>AM</td></tr> <tr><td>AN</td></tr> <tr><td>AP</td></tr> <tr><td>AQ</td></tr> <tr><td>AR</td></tr> <tr><td>AS</td></tr> <tr><td>AT</td></tr> <tr><td>AU</td></tr> <tr><td>AV</td></tr> <tr><td>AY</td></tr> <tr><td>AZ</td></tr> </table>	10	20	30	40	50	60	A0	A5	A6	AM	AN	AP	AQ	AR	AS	AT	AU	AV	AY	AZ
0: direct-coupled (without a motor)																																							
1: direct-coupled (with a motor, specified by the customer)																																							
0: without a cover																																							
1: with a cover																																							
2: with a bellows																																							
0: none																																							
1																																							
2																																							
6																																							
7																																							
B																																							
E																																							
H																																							
L																																							
J																																							
M																																							
10																																							
20																																							
30																																							
40																																							
50																																							
60																																							
A0																																							
A5																																							
A6																																							
AM																																							
AN																																							
AP																																							
AQ																																							
AR																																							
AS																																							
AT																																							
AU																																							
AV																																							
AY																																							
AZ																																							
<p>If "0" is selected, a coupling is not attached. If a coupling is required, please indicate so.</p> <p>"1" means that a motor specified by the customer is mounted.</p> <p>For item ⑨, select a housing A/intermediate flange that matches the specified motor.</p> <p>Several motors by different manufacturers can be mounted. Contact THK for details.</p>																																							

A type with a wrap-around housing A and a motor wrap-around type, which are not contained in the catalog, are also available. Contact THK for details.

Model KR15 Standard Type

Model KR15□□A (with a Single Long Nut Block)

Model KR15□□B (with Two Long Nut Blocks)

For model number coding, see **A2-96**.

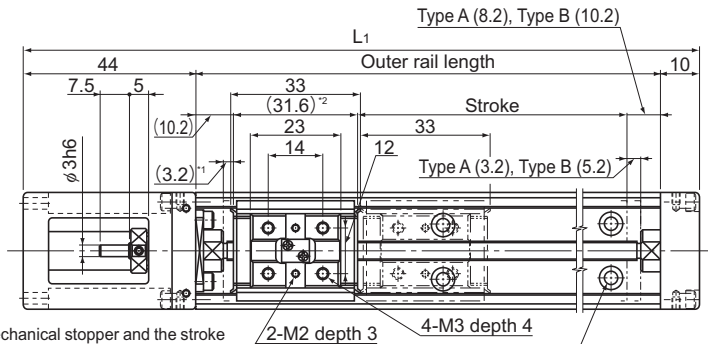

*1 Distance between the mechanical stopper and the stroke starting position.

*2 Indicates the inner block length when calculating the available stroke range. The length in model KR-B (with two long-type inner blocks) is 64.6 mm.

2x n-3.4 through hole, $\phi 6$ counter bore depth 2
(Fixed using M3 hexagon socket button bolt)

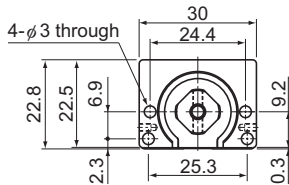
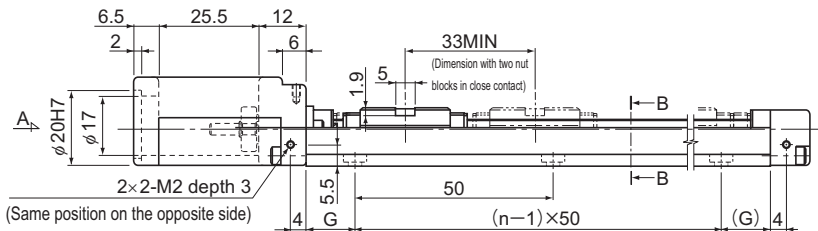

A arrow view

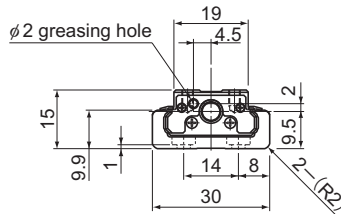

B-B cross section

Stroke (mm) (stroke between mechanical stoppers)		Outer rail length (mm)	Overall length L_1 (mm)	G (mm)	n	Overall main unit mass (kg)	
Type A	Type B					Type A	Type B
25(31.4)	—	75	129	12.5	2	0.19	—
50(56.4)	—	100	154	25	2	0.22	—
75(81.4)	40(48.4)	125	179	12.5	3	0.25	0.292
100(106.4)	65(73.4)	150	204	25	3	0.28	0.322
125(131.4)	90(98.4)	175	229	12.5	4	0.31	0.352
150(156.4)	115(123.4)	200	254	25	4	0.34	0.382

*Indicates a value when two inner blocks are in close contact with each other.

Model KR15 (with a Cover)

Model KR15□□A (with a Single Long Nut Block)

Model KR15□□B (with Two Long Nut Blocks)

For model number coding, see **A2-96**.

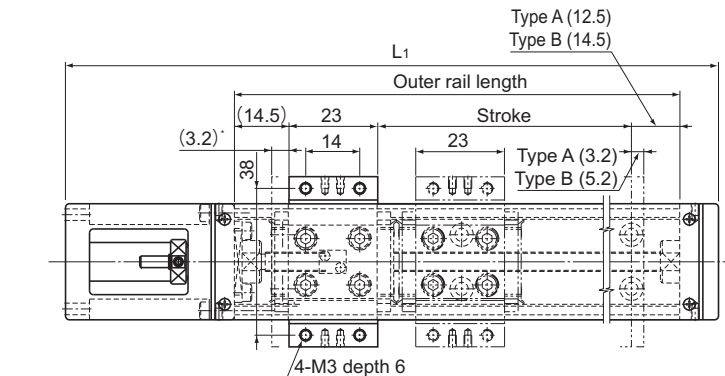

* Distance between the mechanical stopper and the stroke starting position.

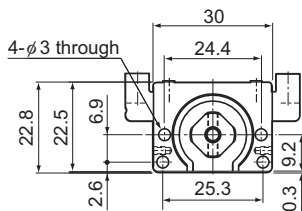
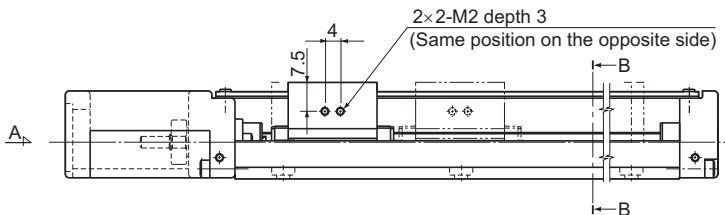

A arrow view

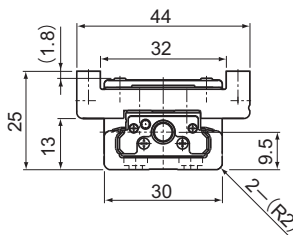

B-B cross section

Stroke (mm) (stroke between mechanical stoppers)		Outer rail length (mm)	Overall length L ₁ (mm)	Overall main unit mass (kg)	
Type A	Type B			Type A	Type B
25(31.4)	—	75	129	0.23	—
50(56.4)	—	100	154	0.26	—
75(81.4)	40(48.4)	125	179	0.3	0.364
100(106.4)	65(73.4)	150	204	0.33	0.394
125(131.4)	90(98.4)	175	229	0.36	0.424
150(156.4)	115(123.4)	200	254	0.4	0.464

*Indicates a value when two inner blocks are in close contact with each other.

Model KR20 Standard Type

Model KR20□□A (with a Single Long Nut Block)

Model KR20□□B (with Two Long Nut Blocks)

For model number coding, see **A2-96**.

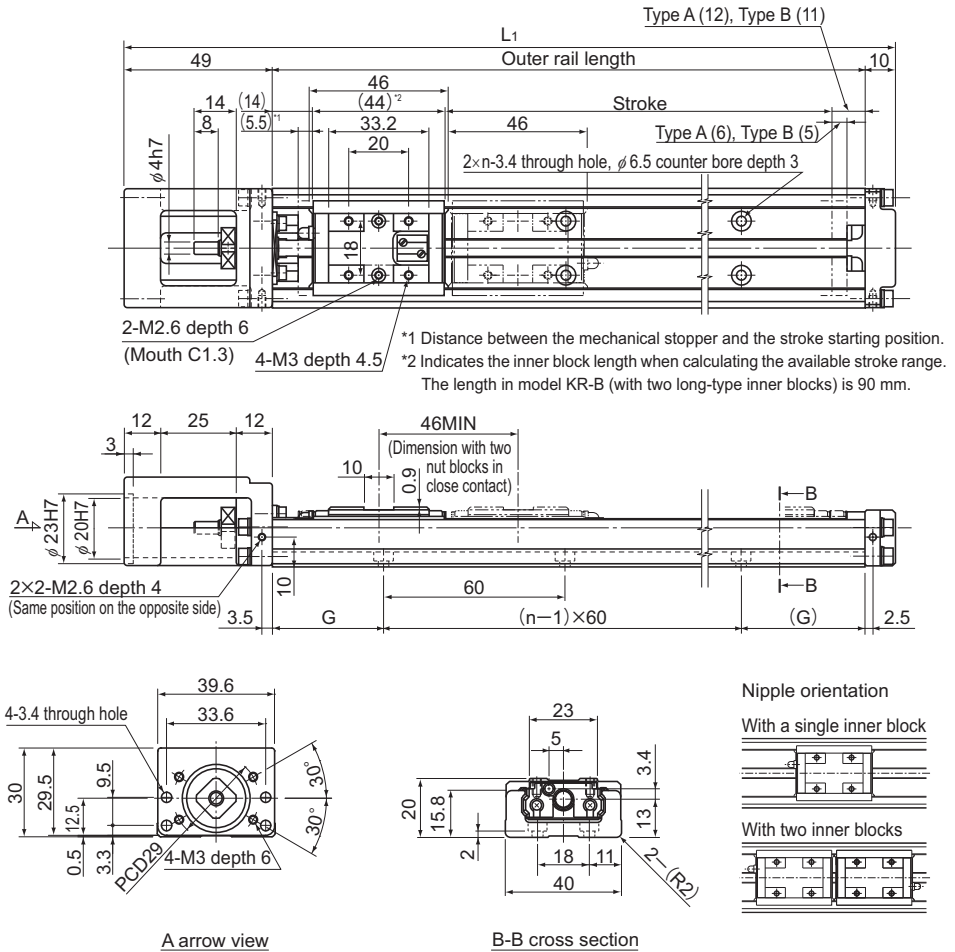

Stroke (mm) (stroke between mechanical stoppers)		Outer rail length (mm)	Overall length L_1 (mm)	G (mm)	n	Overall main unit mass (kg)	
Type A	Type B					Type A	Type B
30(41.5)	—	100	159	20	2	0.45	—
80(91.5)	35(45.5)	150	209	15	3	0.58	0.655
130(141.5)	85(95.5)	200	259	40	3	0.72	0.795

*Indicates a value when two inner blocks are in close contact with each other.

Model KR20 (with a Cover)

Model KR20□□A (with a Single Long Nut Block)

Model KR20□□B (with Two Long Nut Blocks)

For model number coding, see **A2-96**.

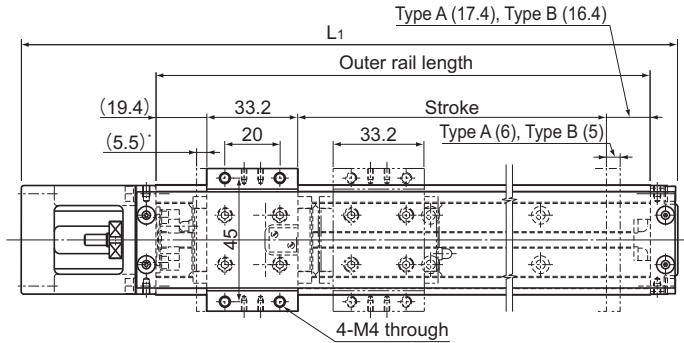

* Distance between the mechanical stopper and the stroke starting position.

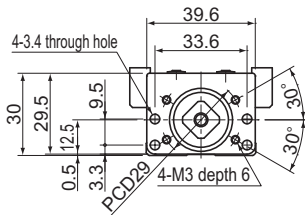
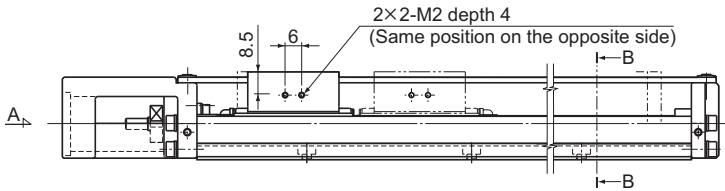

A arrow view

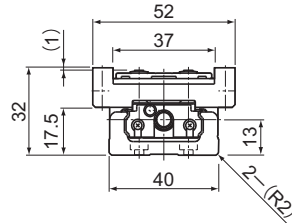

B-B cross section

Stroke (mm) (stroke between mechanical stoppers)		Outer rail length (mm)	Overall length L_1 (mm)	Overall main unit mass (kg)	
Type A	Type B			Type A	Type B
30(41.5)	—	100	159	0.51	—
80(91.5)	35(45.5)	150	209	0.66	0.78
130(141.5)	85(95.5)	200	259	0.8	0.92

*Indicates a value when two inner blocks are in close contact with each other.

Model KR26 Standard Type

Model KR26□□A (with a Single Long Nut Block)

Model KR26□□B (with Two Long Nut Blocks)

For model number coding, see **A2-96**.

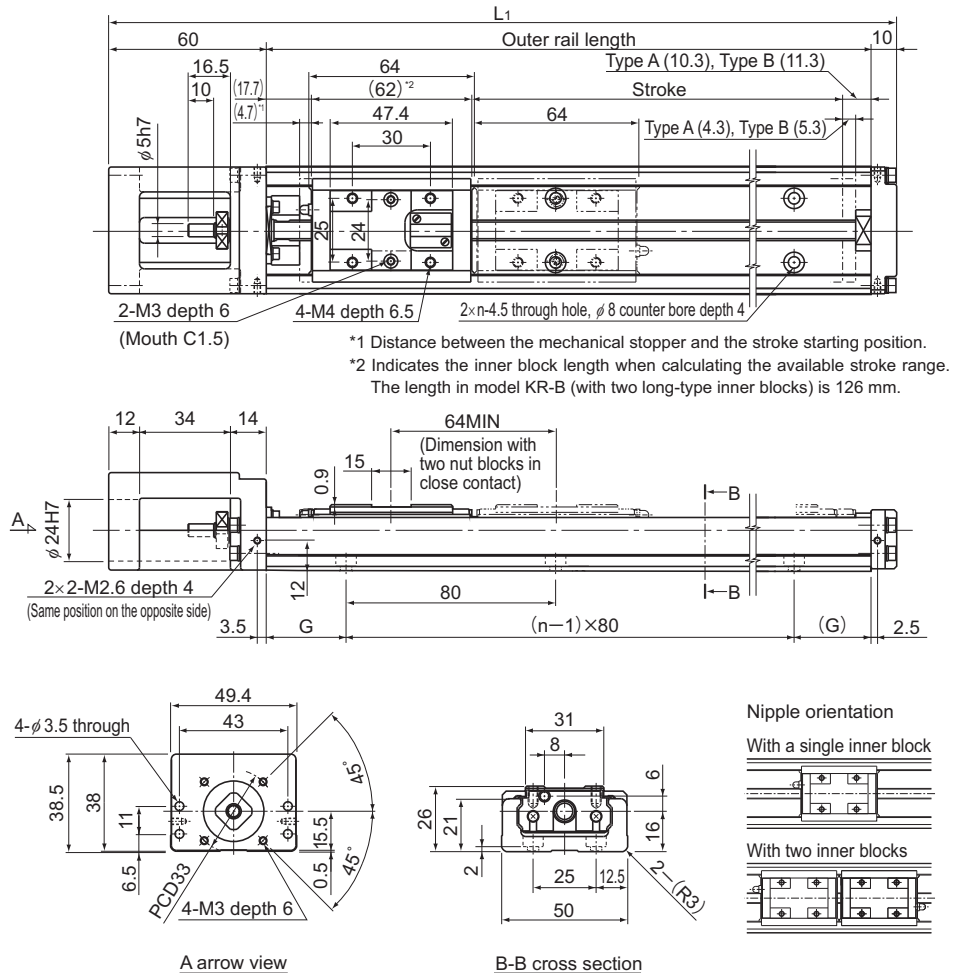

Stroke (mm) (stroke between mechanical stoppers)		Outer rail length (mm)	Overall length L_1 (mm)	G (mm)	n	Overall main unit mass (kg)	
Type A	Type B [*]					Type A	Type B
60(69)	—	150	220	35	2	0.99	—
110(119)	45(55)	200	270	20	3	1.2	1.38
160(169)	95(105)	250	320	45	3	1.41	1.59
210(219)	145(155)	300	370	30	4	1.62	1.8

*Indicates a value when two inner blocks are in close contact with each other.

Model KR26 (with a Cover)

Model KR26□□A (with a Single Long Nut Block)

Model KR26□□B (with Two Long Nut Blocks)

For model number coding, see **A2-96**.

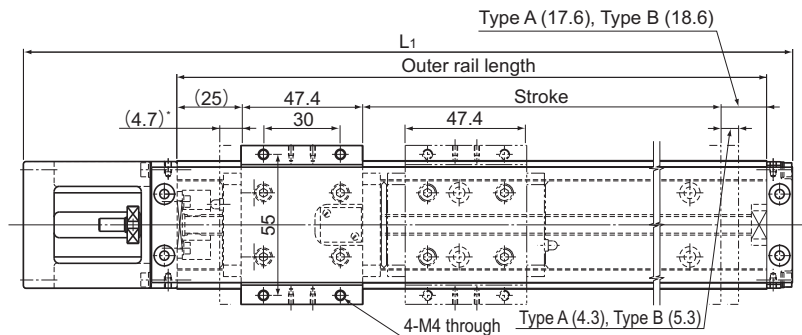

* Distance between the mechanical stopper and the stroke starting position.

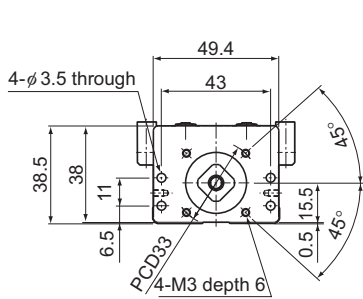
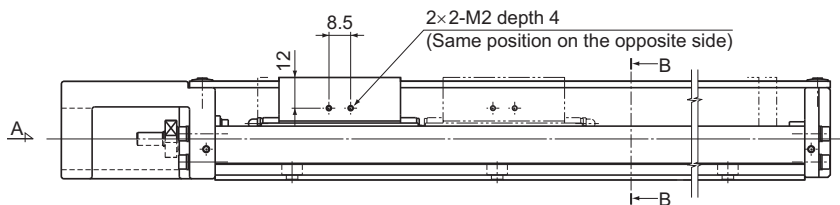

A arrow view

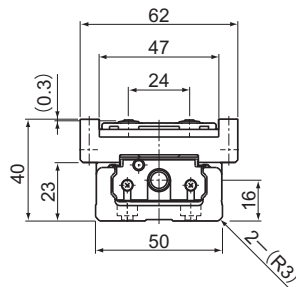

B-B cross section

Stroke (mm) (stroke between mechanical stoppers)		Outer rail length (mm)	Overall length L ₁ (mm)	Overall main unit mass (kg)	
Type A	Type B			Type A	Type B
60(69)	—	150	220	1.12	—
110(119)	45(55)	200	270	1.34	1.605
160(169)	95(105)	250	320	1.56	1.825
210(219)	145(155)	300	370	1.78	2.045

*Indicates a value when two inner blocks are in close contact with each other.

Model KR30H Standard Type

Model KR30H□□A (with a Single Long Nut Block)

Model KR30H□□B (with Two Long Nut Blocks)

For model number coding, see **A2-96**.

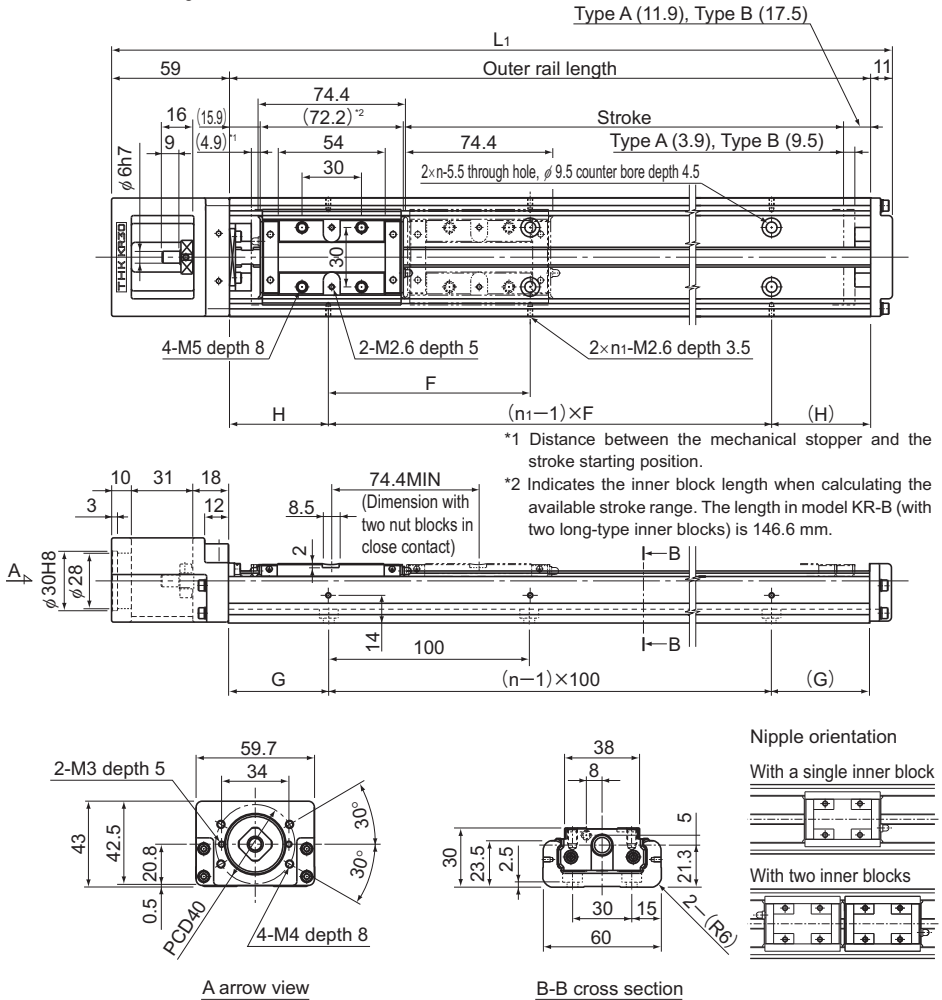

Stroke (mm) (stroke between mechanical stoppers)		Outer rail length (mm)	Overall length L ₁ (mm)	H (mm)	G (mm)	F (mm)	n	n ₁	Overall main unit mass (kg)	
Type A	Type B								Type A	Type B
50(58.8)	—	150	220	25	25	100	2	2	1.4	—
100(108.8)	—	200	270	50	50	100	2	2	1.6	—
200(208.8)	120(134.4)	300	370	50	50	200	3	2	2.2	2.5
300(308.8)	220(234.4)	400	470	100	50	200	4	2	2.7	3
400(408.8)	320(334.4)	500	570	50	50	200	5	3	3.2	3.5
500(508.8)	420(434.4)	600	670	100	50	200	6	3	3.8	4.1

*Indicates a value when two inner blocks are in close contact with each other.

Model KR30H (with a Cover)

Model KR30H□□A (with a Single Long Nut Block)

Model KR30H□□B (with Two Long Nut Blocks)

For model number coding, see **A2-96**.

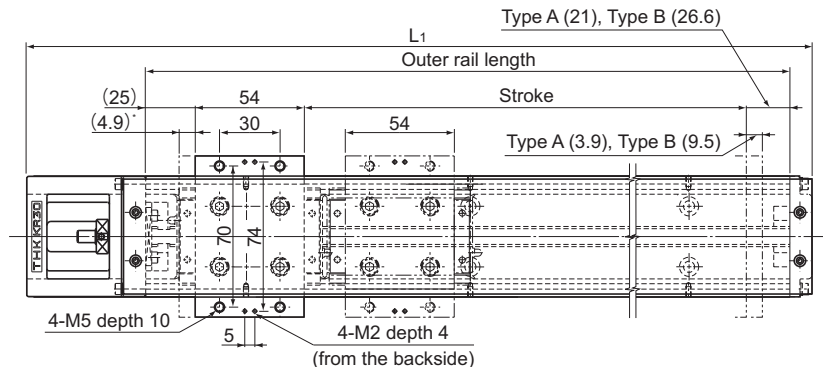

* Distance between the mechanical stopper and the stroke starting position.

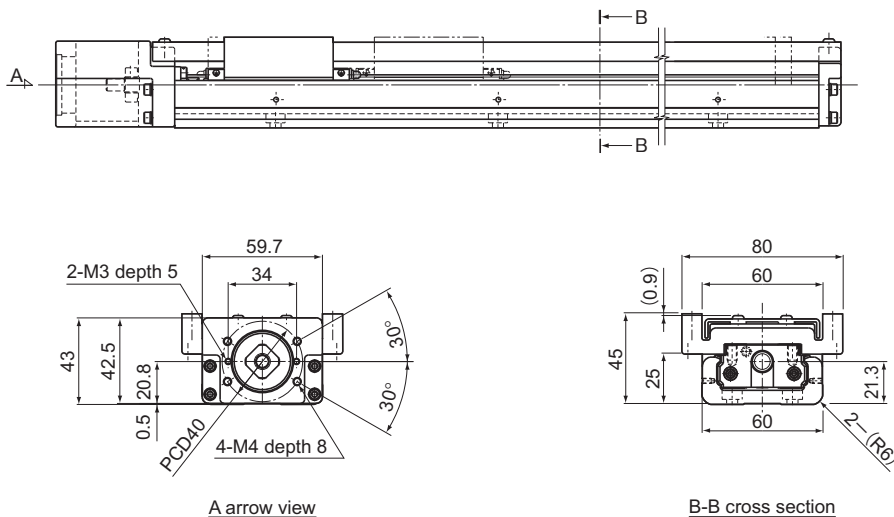

Stroke (mm) (stroke between mechanical stoppers)		Outer rail length (mm)	Overall length L_1 (mm)	Overall main unit mass (kg)	
Type A	Type B			Type A	Type B
50(58.8)	—	150	220	1.6	—
100(108.8)	—	200	270	1.8	—
200(208.8)	120(134.4)	300	370	2.4	2.83
300(308.8)	220(234.4)	400	470	3	3.43
400(408.8)	320(334.4)	500	570	3.5	3.93
500(508.8)	420(434.4)	600	670	4.1	4.53

*Indicates a value when two inner blocks are in close contact with each other.

Model KR30H Standard Type

Model KR30H□□C (with a Single Short Nut Block)

Model KR30H□□D (with Two Short Nut Blocks)

For model number coding, see **A2-96**.

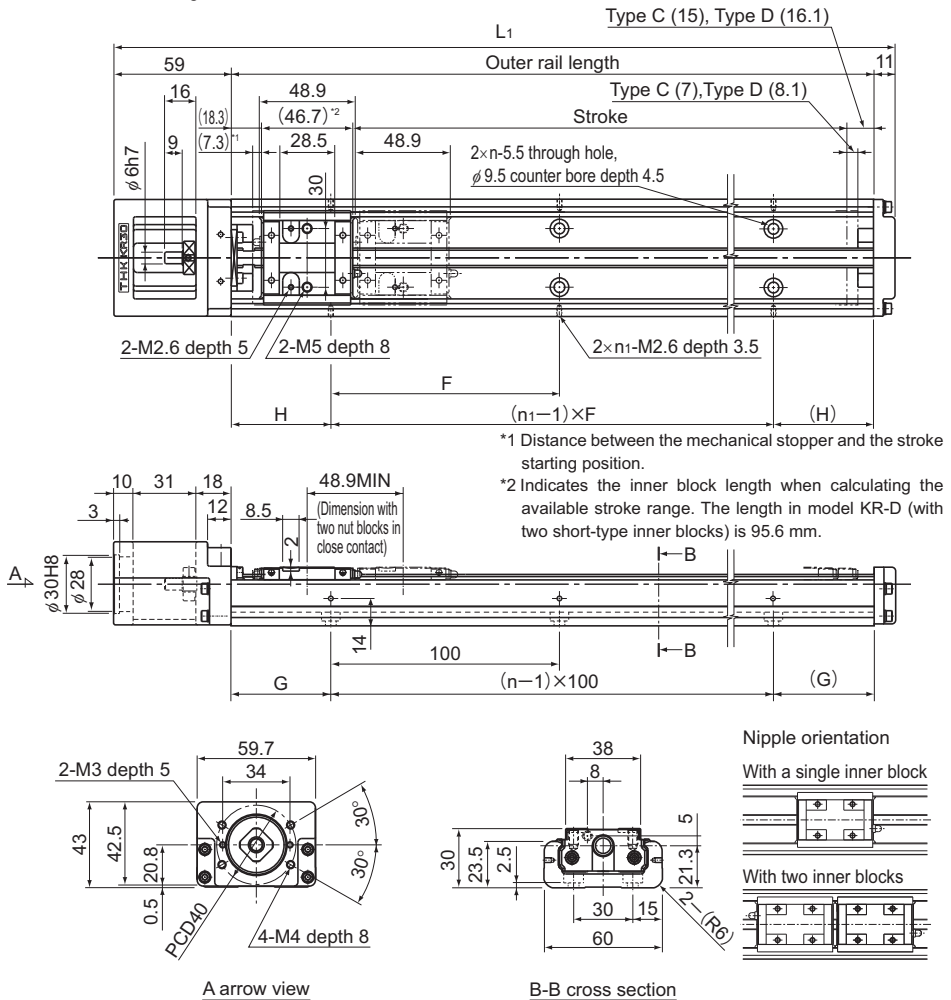

A arrow view

B-B cross section

Stroke (mm) (stroke between mechanical stoppers)		Outer rail length (mm)	Overall length L_1 (mm)	H (mm)	G (mm)	F (mm)	n	n_1	Overall main unit mass (kg)	
Type C	Type D								Type C	Type D
70(84.3)	20(35.4)	150	220	25	25	100	2	2	1.3	1.47
120(134.3)	70(85.4)	200	270	50	50	100	2	2	1.5	1.67
220(234.3)	170(185.4)	300	370	50	50	200	3	2	2.1	2.27
320(334.3)	270(285.4)	400	470	100	50	200	4	2	2.6	2.77
420(434.3)	370(385.4)	500	570	50	50	200	5	3	3.1	3.27
520(534.3)	470(485.4)	600	670	100	50	200	6	3	3.7	3.87

*Indicates a value when two inner blocks are in close contact with each other.

Model KR30H (with a Cover)

Model KR30H□□C (with a Single Short Nut Block)

Model KR30H□□D (with Two Short Nut Blocks)

For model number coding, see **A2-96**.

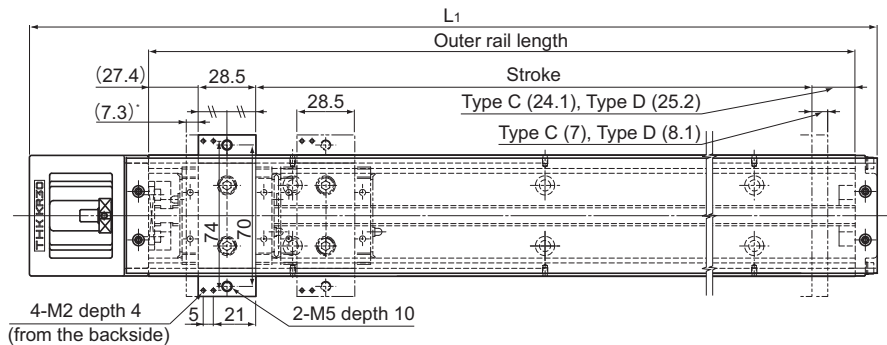

* Distance between the mechanical stopper and the stroke starting position.

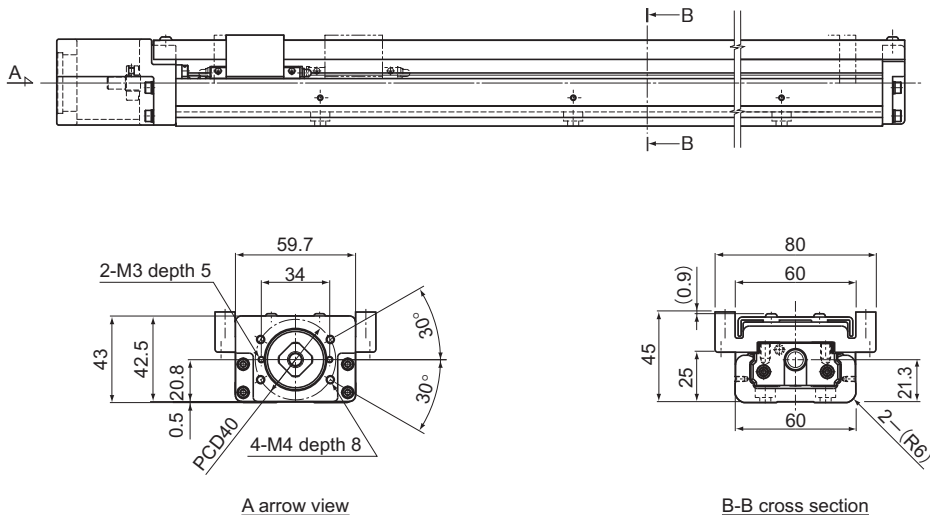

A arrow view

B-B cross section

Stroke (mm) (stroke between mechanical stoppers)		Outer rail length (mm)	Overall length L_1 (mm)	Overall main unit mass (kg)	
Type C	Type D			Type C	Type D
70(84.3)	20(35.4)	150	220	1.4	1.64
120(134.3)	70(85.4)	200	270	1.6	1.84
220(234.3)	170(185.4)	300	370	2.2	2.44
320(334.3)	270(285.4)	400	470	2.8	3.04
420(434.3)	370(385.4)	500	570	3.3	3.54
520(534.3)	470(485.4)	600	670	3.9	4.14

*Indicates a value when two inner blocks are in close contact with each other.

Model KR33 Standard Type

Model KR33□□A (with a Single Long Nut Block)

Model KR33□□B (with Two Long Nut Blocks)

For model number coding, see **A2-96**.

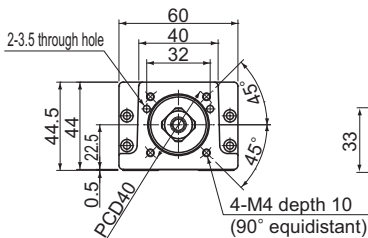
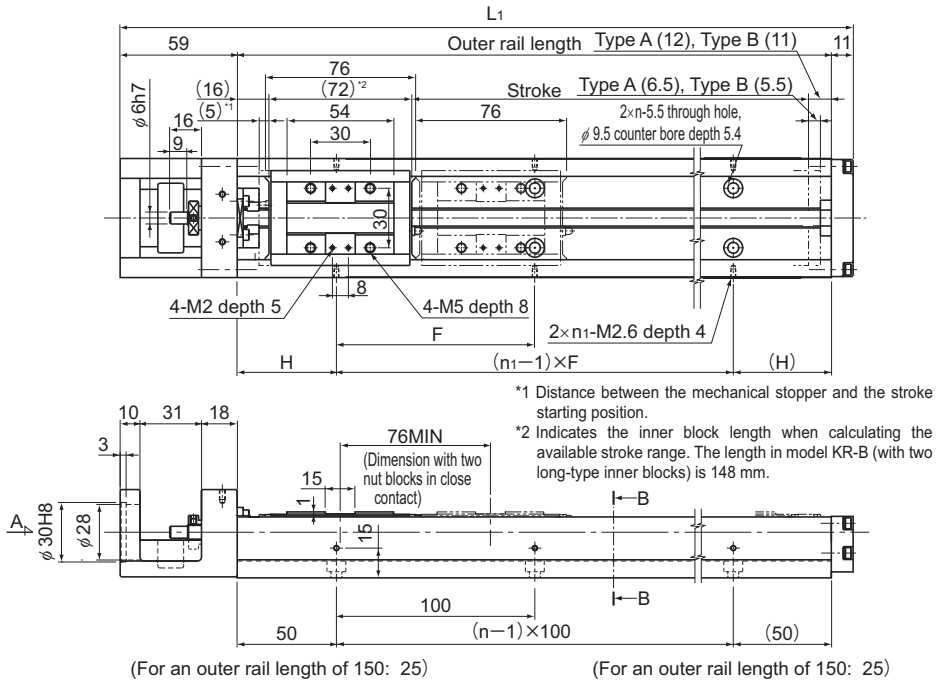

A arrow view

B-B cross section

Nipple orientation

With a single inner block

With two inner blocks

Stroke (mm) (stroke between mechanical stoppers)		Outer rail length (mm)	Overall length L_1 (mm)	H (mm)	F (mm)	n	n_1	Overall main unit mass (kg)	
Type A	Type B [*]							Type A	Type B
50(61.5)	—	150	220	25	100	2	2	1.7	—
100(111.5)	—	200	270	50	100	2	2	2	—
200(211.5)	125(135.5)	300	370	50	200	3	2	2.6	2.95
300(311.5)	225(235.5)	400	470	100	200	4	2	3.2	3.55
400(411.5)	325(335.5)	500	570	50	200	5	3	3.9	4.25
500(511.5)	425(435.5)	600	670	100	200	6	3	4.5	4.85
600(611.5)	525(535.5)	700	770	50	200	7	4	5.5	5.85

*Indicates a value when two inner blocks are in close contact with each other.

Model KR33 (with a Cover)

Model KR33□□A (with a Single Long Nut Block)

Model KR33□□B (with Two Long Nut Blocks)

For model number coding, see **A2-96**.

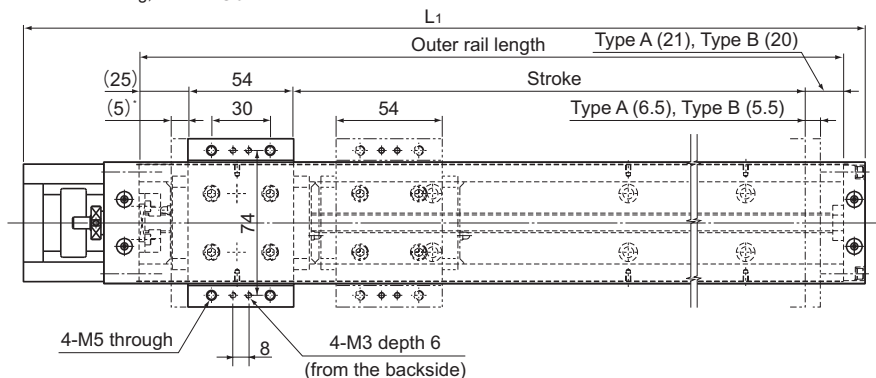

* Distance between the mechanical stopper and the stroke starting position.

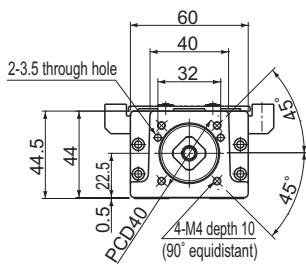
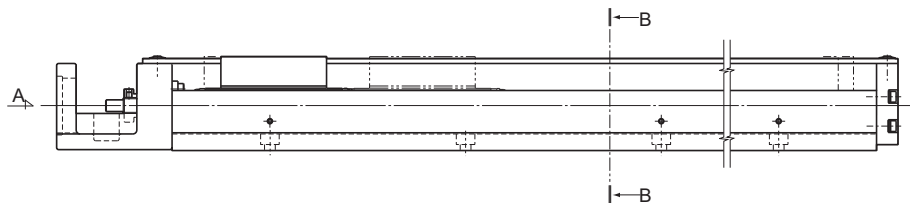

A arrow view

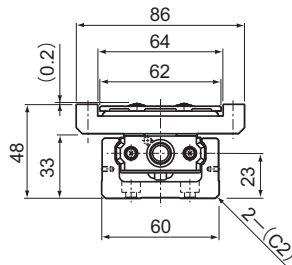

B-B cross section

Stroke (mm) (stroke between mechanical stoppers)		Outer rail length (mm)	Overall length L_1 (mm)	Overall main unit mass (kg)	
Type A	Type B*			Type A	Type B
50(61.5)	—	150	220	1.9	—
100(111.5)	—	200	270	2.2	—
200(211.5)	125(135.5)	300	370	2.8	3.28
300(311.5)	225(235.5)	400	470	3.5	3.98
400(411.5)	325(335.5)	500	570	4.2	4.68
500(511.5)	425(435.5)	600	670	4.8	5.28
600(611.5)	525(535.5)	700	770	5.9	6.38

*Indicates a value when two inner blocks are in close contact with each other.

Note) It must be noted that the cover-mounting bolt is 0.2 mm higher than the top face of the top table.

Model KR33 Standard Type

Model KR33□□C (with a Single Short Nut Block)

Model KR33□□D (with Two Short Nut Blocks)

For model number coding, see **A2-96**.

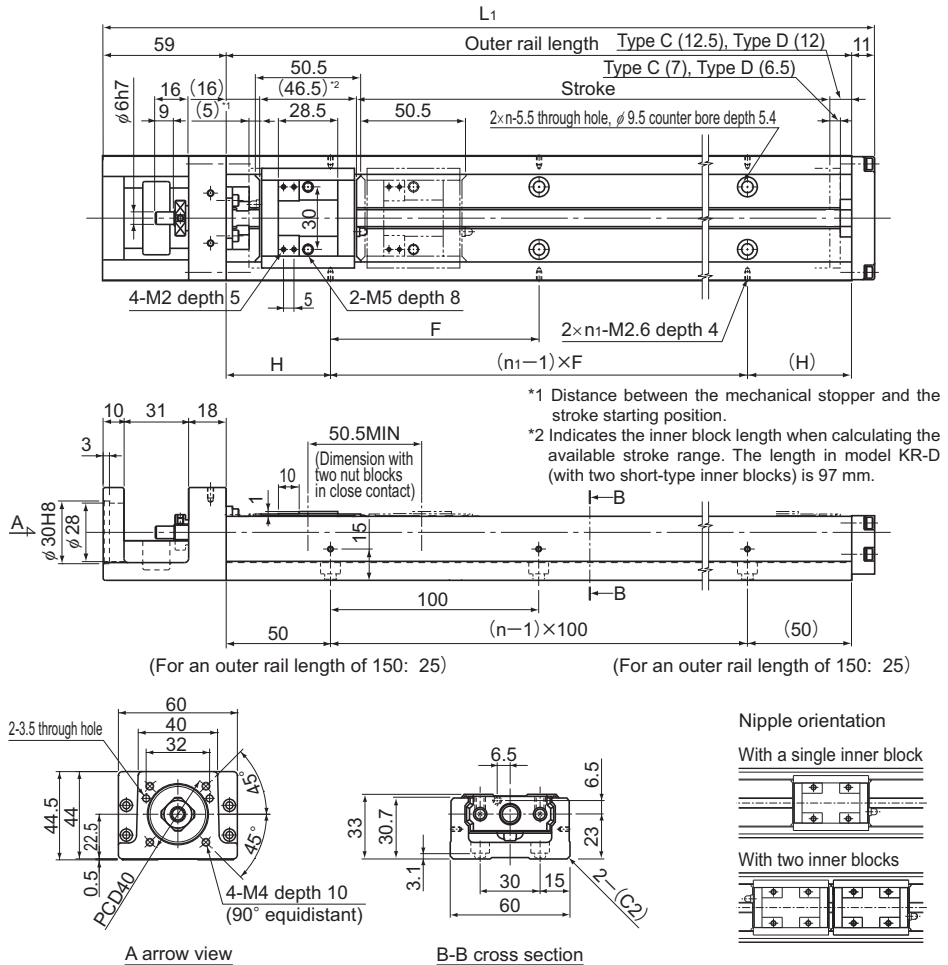

Stroke (mm) (stroke between mechanical stoppers)		Outer rail length (mm)	Overall length L_1 (mm)	H (mm)	F (mm)	n	n_1	Overall main unit mass (kg)	
Type C	Type D*							Type C	Type D
75(87)	25(36.5)	150	220	25	100	2	2	1.6	1.83
125(137)	75(86.5)	200	270	50	100	2	2	1.9	2.13
225(237)	175(186.5)	300	370	50	200	3	2	2.5	2.73
325(337)	275(286.5)	400	470	100	200	4	2	3.1	3.33
425(437)	375(386.5)	500	570	50	200	5	3	3.8	4.03
525(537)	475(486.5)	600	670	100	200	6	3	4.4	4.63
625(637)	575(586.5)	700	770	50	200	7	4	5.4	5.63

*Indicates a value when two inner blocks are in close contact with each other.

Model KR33 (with a Cover)

Model KR33□□C (with a Single Short Nut Block)

Model KR33□□D (with Two Short Nut Blocks)

For model number coding, see **A2-96**.

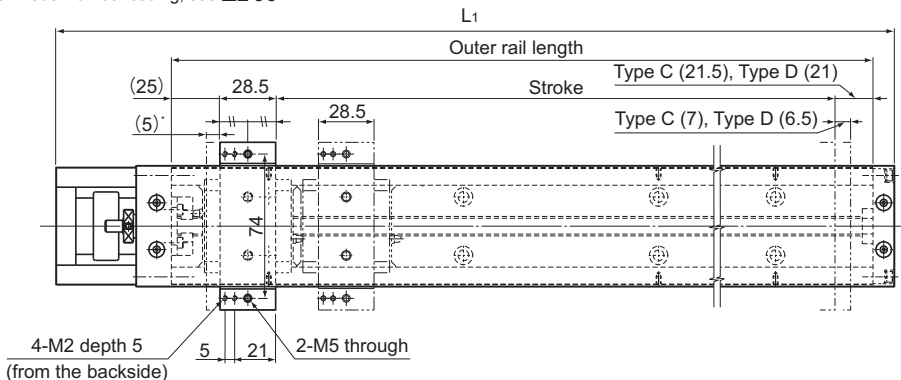

* Distance between the mechanical stopper and the stroke starting position.

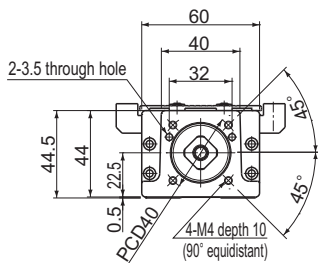
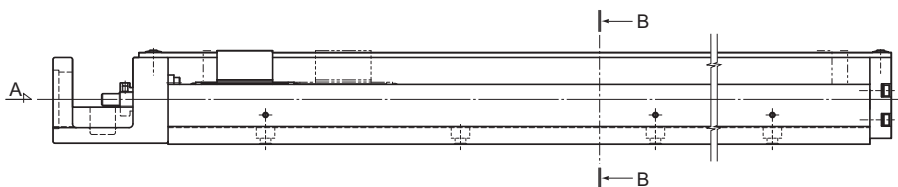

A arrow view

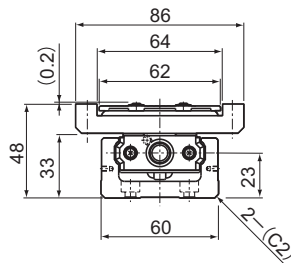

B-B cross section

Stroke (mm) (stroke between mechanical stoppers)		Outer rail length (mm)	Overall length L_1 (mm)	Overall main unit mass (kg)	
Type C	Type D [*]			Type C	Type D
75(87)	25(36.5)	150	220	1.7	2
125(137)	75(86.5)	200	270	2.1	2.4
225(237)	175(186.5)	300	370	2.7	3
325(337)	275(286.5)	400	470	3.3	3.6
425(437)	375(386.5)	500	570	4	4.3
525(537)	475(486.5)	600	670	4.7	5
625(637)	575(586.5)	700	770	5.7	5.93

* Indicates a value when two inner blocks are in close contact with each other.

Note) It must be noted that the cover-mounting bolt is 0.2 mm higher than the top face of the top table.

Model KR45H Standard Type

Model KR45H□□A (with a Single Long Nut Block)

Model KR45H□□B (with Two Long Nut Blocks)

For model number coding, see **A2-96**.

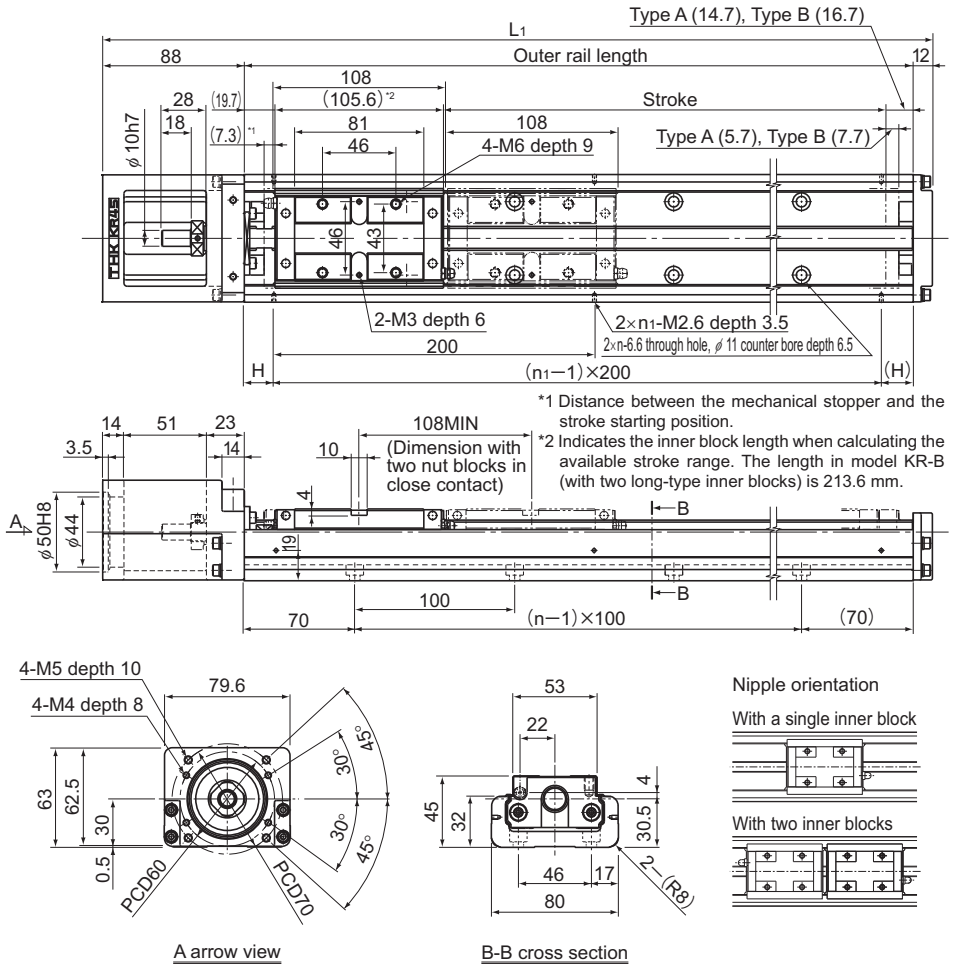

Stroke (mm) (stroke between mechanical stoppers)		Outer rail length (mm)	Overall length L ₁ (mm)	H (mm)	n	n ₁	Overall main unit mass (kg)	
Type A	Type B [*]						Type A	Type B
200(213)	90(105)	340	440	70	3	2	5.1	6.05
300(313)	190(205)	440	540	20	4	3	6.1	7.05
400(413)	290(305)	540	640	70	5	3	7.1	8.05
500(513)	390(405)	640	740	20	6	4	8.1	9.05
600(613)	490(505)	740	840	70	7	4	9.1	10.05
700(713)	590(605)	840	940	20	8	5	10.1	11.05
800(813)	690(705)	940	1040	70	9	5	11.2	12.15

^{*}Indicates a value when two inner blocks are in close contact with each other.

Model KR45H (with a Cover)

Model KR45H□□A (with a Single Long Nut Block)

Model KR45H□□B (with Two Long Nut Blocks)

For model number coding, see **A2-96**.

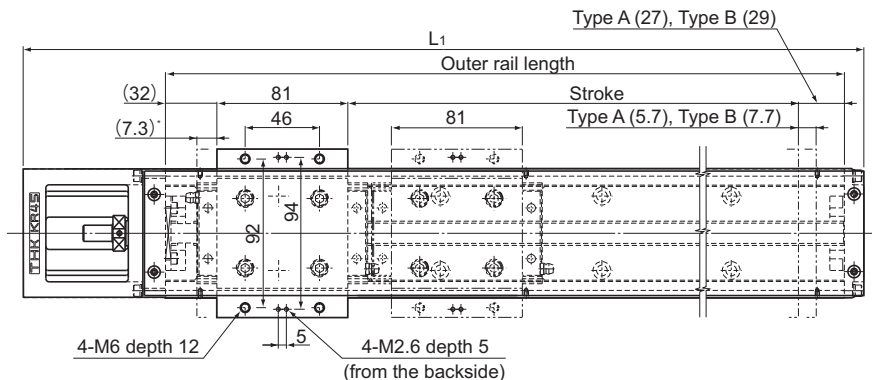

* Distance between the mechanical stopper and the stroke starting position.

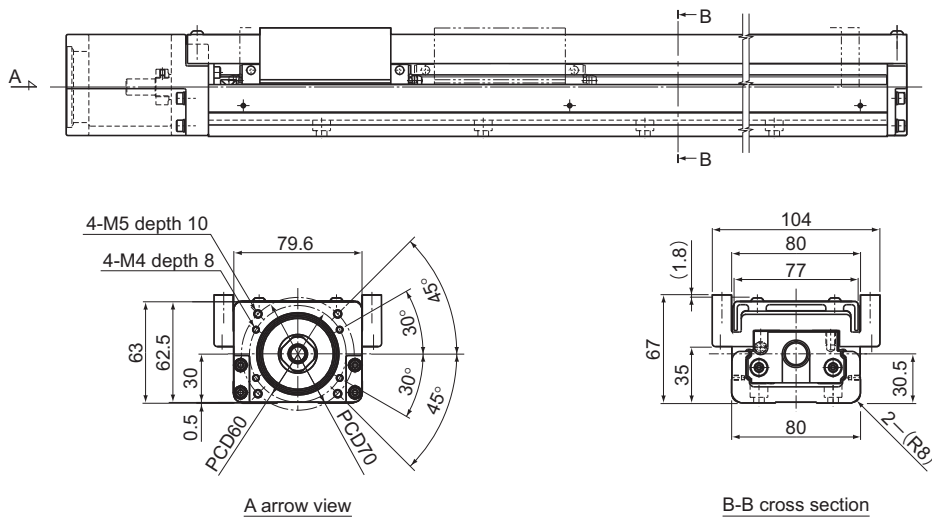

Stroke (mm) (stroke between mechanical stoppers)		Outer rail length (mm)	Overall length L_1 (mm)	Overall main unit mass (kg)	
Type A	Type B [*]			Type A	Type B
200(213)	90(105)	340	440	5.7	7.01
300(313)	190(205)	440	540	6.8	8.11
400(413)	290(305)	540	640	7.9	9.21
500(513)	390(405)	640	740	9	10.31
600(613)	490(505)	740	840	10.1	11.41
700(713)	590(605)	840	940	11.2	12.51
800(813)	690(705)	940	1040	12.3	13.61

*Indicates a value when two inner blocks are in close contact with each other.

Model KR45H Standard Type

Model KR45H□□C (with a Single Short Nut Block)

Model KR45H□□D (with Two Short Nut Blocks)

For model number coding, see **A2-96**.

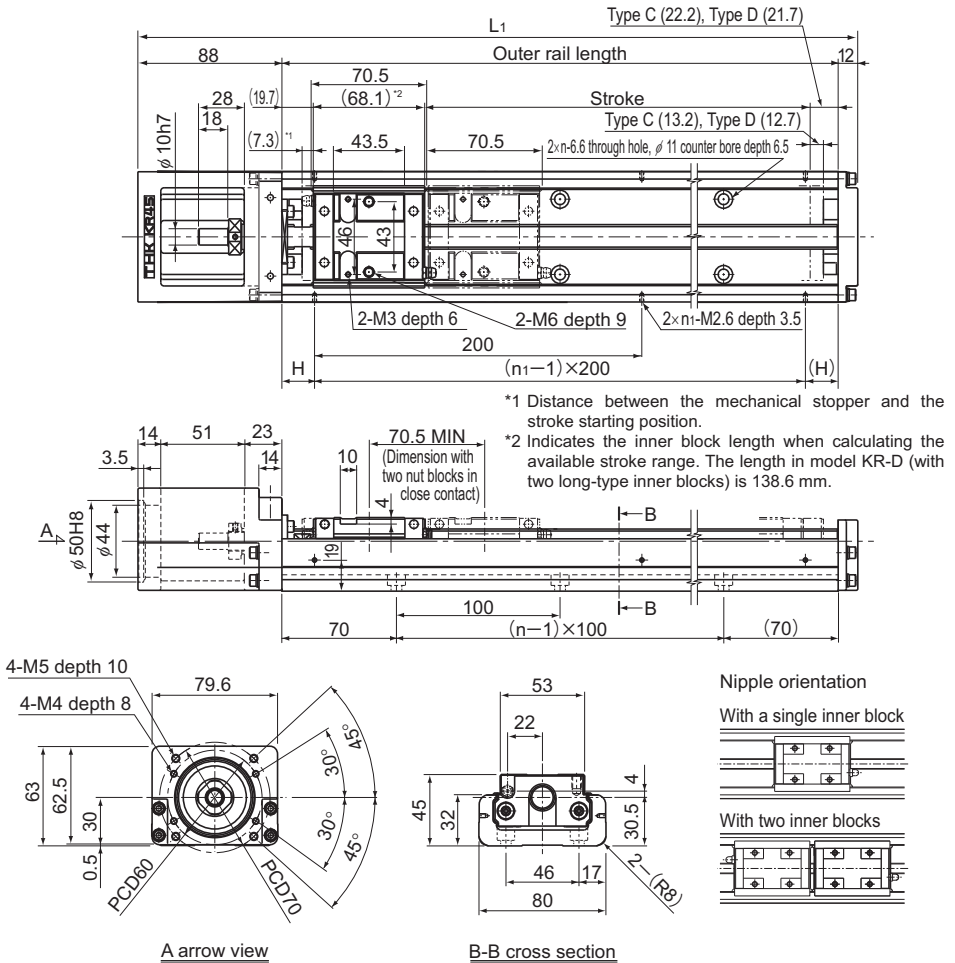

Stroke (mm) (stroke between mechanical stoppers)		Outer rail length (mm)	Overall length L_1 (mm)	H (mm)	n	n_1	Overall main unit mass (kg)	
Type C	Type D*						Type C	Type D
230(250.5)	160(180)	340	440	70	3	2	4.7	5.23
330(350.5)	260(280)	440	540	70	4	3	5.7	6.23
430(450.5)	360(380)	540	640	70	5	3	6.7	7.23
530(550.5)	460(480)	640	740	20	6	4	7.7	8.23
630(650.5)	560(580)	740	840	70	7	4	8.7	9.23
730(750.5)	660(680)	840	940	20	8	5	9.7	10.23
830(850.5)	760(780)	940	1040	70	9	5	10.8	11.33

*Indicates a value when two inner blocks are in close contact with each other.

Model KR45H (with a Cover)

Model KR45H□□C (with a Single Short Nut Block)

Model KR45H□□D (with Two Short Nut Blocks)

For model number coding, see **A2-96**.

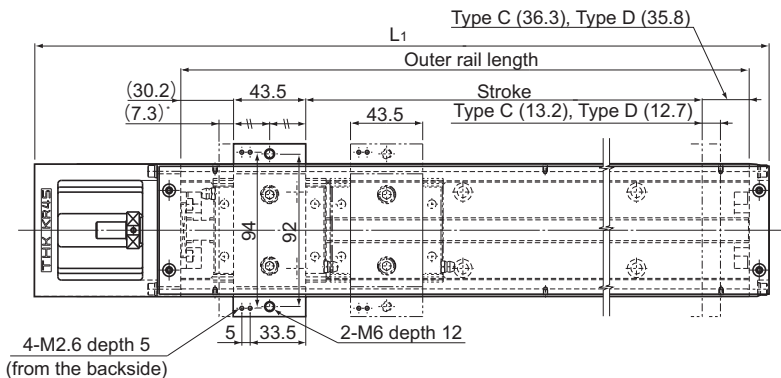

* Distance between the mechanical stopper and the stroke starting position.

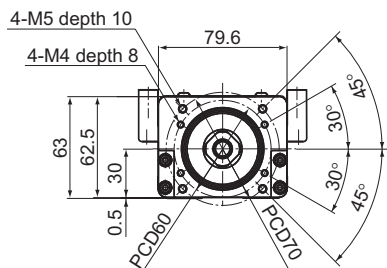
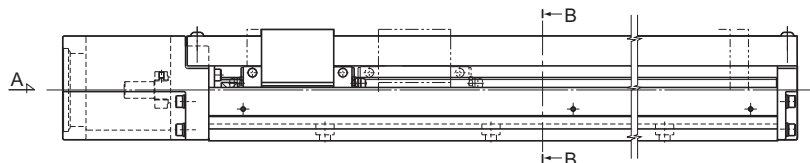

A arrow view

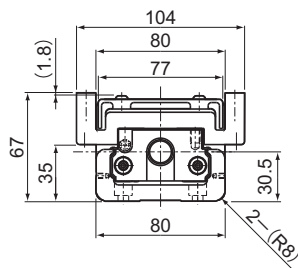

B-B cross section

Stroke (mm) (stroke between mechanical stoppers)		Outer rail length (mm)	Overall length L_1 (mm)	Overall main unit mass (kg)	
Type C	Type D			Type C	Type D
230(250.5)	160(180)	340	440	5.1	5.82
330(350.5)	260(280)	440	540	6.2	6.92
430(450.5)	360(380)	540	640	7.3	8.02
530(550.5)	460(480)	640	740	8.4	9.12
630(650.5)	560(580)	740	840	9.5	10.22
730(750.5)	660(680)	840	940	10.6	11.32
830(850.5)	760(780)	940	1040	11.7	12.42

*Indicates a value when two inner blocks are in close contact with each other.

Model KR46 Standard Type

Model KR46□□A (with a Single Long Nut Block)

Model KR46□□B (with Two Long Nut Blocks)

For model number coding, see **A2-96**.

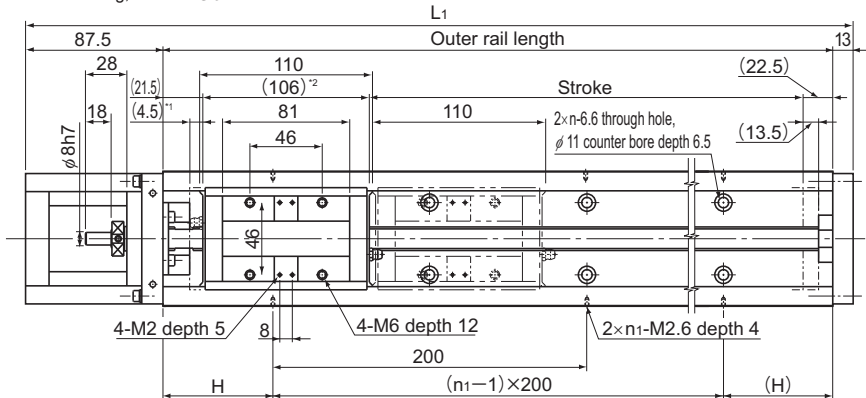

*1 Distance between the mechanical stopper and the stroke starting position.

*2 Indicates the inner block length when calculating the available stroke range. The length in model KR-B (with two long-type inner blocks) is 216 mm.

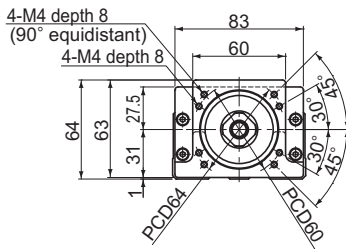
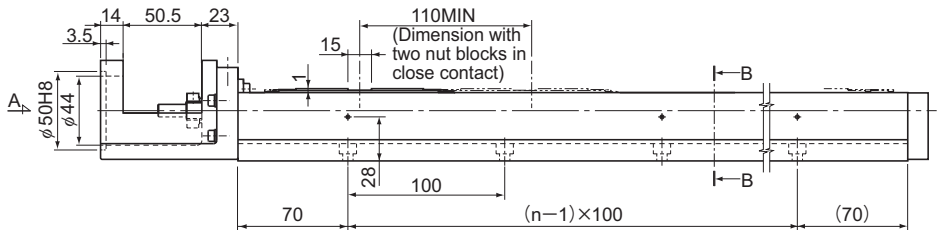

A arrow view

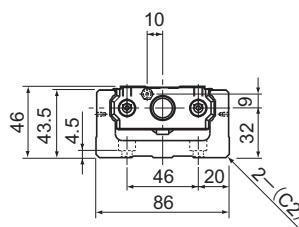

B-B cross section

Nipple orientation

With a single inner block

With two inner blocks

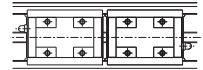

Stroke (mm) (stroke between mechanical stoppers)		Outer rail length (mm)	Overall length L ₁ (mm)	H (mm)	n	n ₁	Overall main unit mass (kg)	
Type A	Type B						Type A	Type B
190(208)	80(98)	340	440.5	70	3	2	7.7	8.9
290(308)	180(198)	440	540.5	20	4	3	9	10.2
390(408)	280(298)	540	640.5	70	5	3	10.3	11.5
490(508)	380(398)	640	740.5	20	6	4	11.6	12.8
590(608)	480(498)	740	840.5	70	7	4	12.8	14
690(708)	580(598)	840	940.5	20	8	5	14.1	15.3
790(808)	680(698)	940	1040.5	70	9	5	15.3	16.5

*Indicates a value when two inner blocks are in close contact with each other.

Model KR46 (with a Cover)

Model KR46□□A (with a Single Long Nut Block)

Model KR46□□B (with Two Long Nut Blocks)

For model number coding, see **A2-96**.

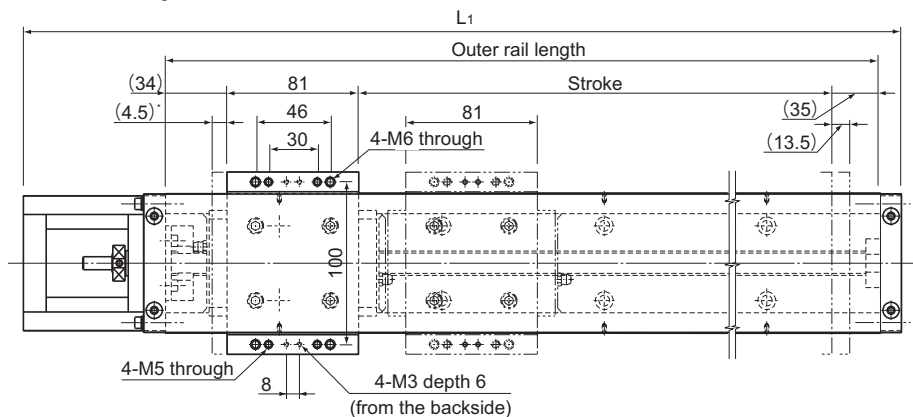

* Distance between the mechanical stopper and the stroke starting position.

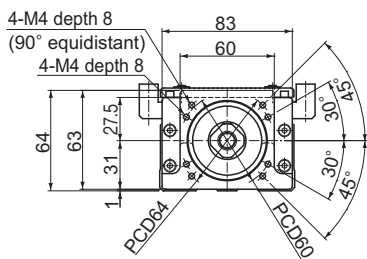
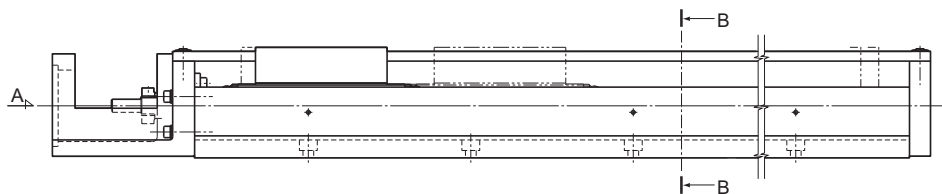

A arrow view

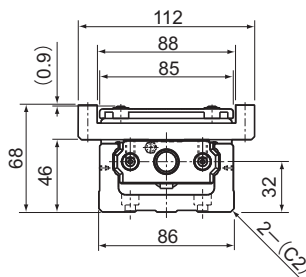

B-B cross section

Stroke (mm) (stroke between mechanical stoppers)		Outer rail length (mm)	Overall length L_1 (mm)	Overall main unit mass (kg)	
Type A	Type B*			Type A	Type B
190(208)	80(98)	340	440.5	8.3	9.79
290(308)	180(198)	440	540.5	9.7	11.19
390(408)	280(298)	540	640.5	11	12.49
490(508)	380(398)	640	740.5	12.4	13.89
590(608)	480(498)	740	840.5	13.7	15.19
690(708)	580(598)	840	940.5	15	16.49
790(808)	680(698)	940	1040.5	16.3	17.79

*Indicates a value when two inner blocks are in close contact with each other.

Model KR46 Standard Type

Model KR46□□C (with a Single Short Nut Block)

Model KR46□□D (with Two Short Nut Blocks)

For model number coding, see **A2-96**.

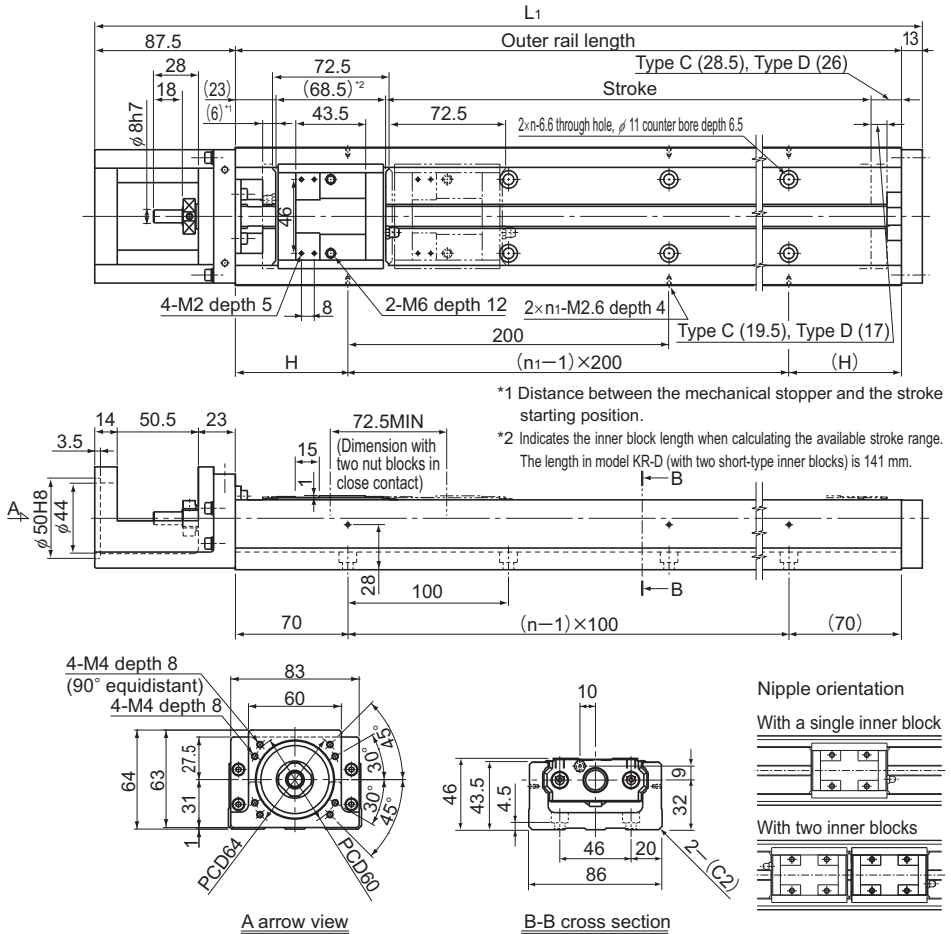

Stroke (mm) (stroke between mechanical stoppers)		Outer rail length (mm)	Overall length L_1 (mm)	H (mm)	n	n_1	Overall main unit mass (kg)	
Type C	Type D'						Type C	Type D
220(245.5)	150(173)	340	440.5	70	3	2	7.3	8.1
320(345.5)	250(273)	440	540.5	20	4	3	8.6	9.4
420(445.5)	350(373)	540	640.5	70	5	3	9.9	10.7
520(545.5)	450(473)	640	740.5	20	6	4	11.2	12
620(645.5)	550(573)	740	840.5	70	7	4	12.4	13.2
720(745.5)	650(673)	840	940.5	20	8	5	13.7	14.5
820(845.5)	750(773)	940	1040.5	70	9	5	14.9	15.7

*Indicates a value when two inner blocks are in close contact with each other.

Model KR46 (with a Cover)

Model KR46□□C (with a Single Short Nut Block)

Model KR46□□D (with Two Short Nut Blocks)

For model number coding, see **A2-96**.

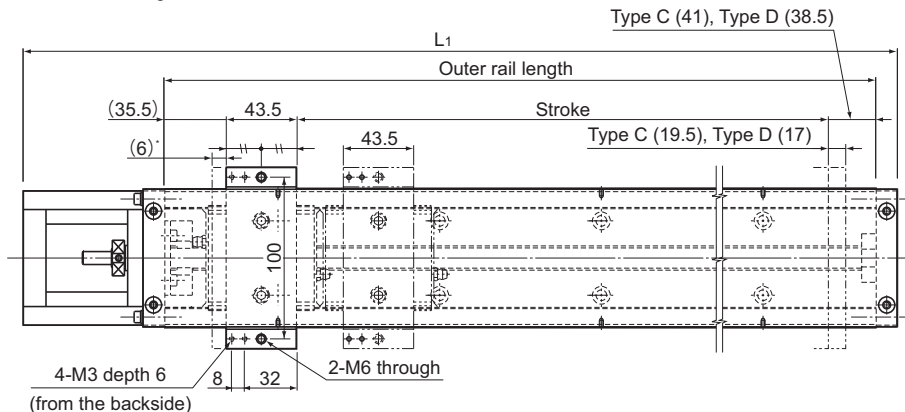

* Distance between the mechanical stopper and the stroke starting position.

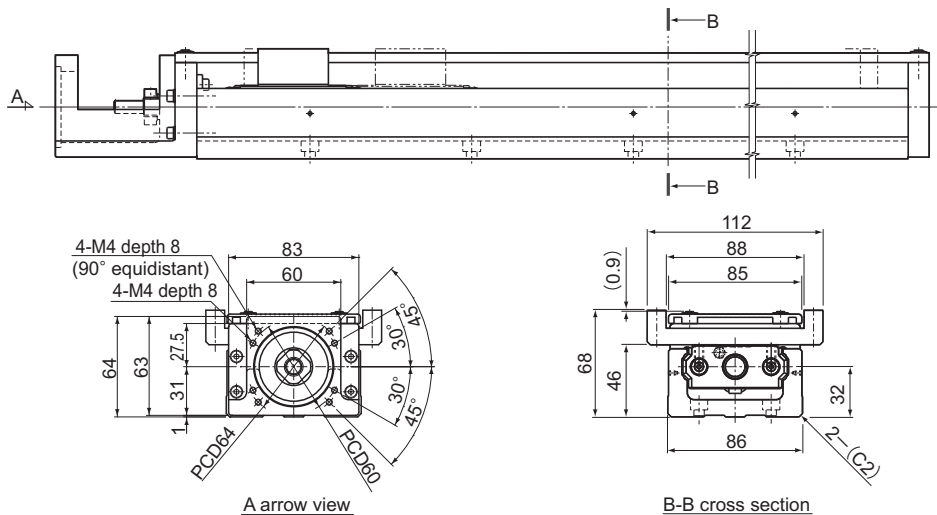

Stroke (mm) (stroke between mechanical stoppers)		Outer rail length (mm)	Overall length L ₁ (mm)	Overall main unit mass (kg)	
Type C	Type D			Type C	Type D
220(245.5)	150(173)	340	440.5	7.8	8.79
320(345.5)	250(273)	440	540.5	9.1	10.09
420(445.5)	350(373)	540	640.5	10.5	11.49
520(545.5)	450(473)	640	740.5	11.9	12.89
620(645.5)	550(573)	740	840.5	13.2	14.19
720(745.5)	650(673)	840	940.5	14.5	15.49
820(845.5)	750(773)	940	1040.5	15.8	16.79

*Indicates a value when two inner blocks are in close contact with each other.

Model KR55 Standard Type

Model KR5520A (with a Single Long Nut Block)

Model KR5520B (with Two Long Nut Blocks)

For model number coding, see **A2-96**.

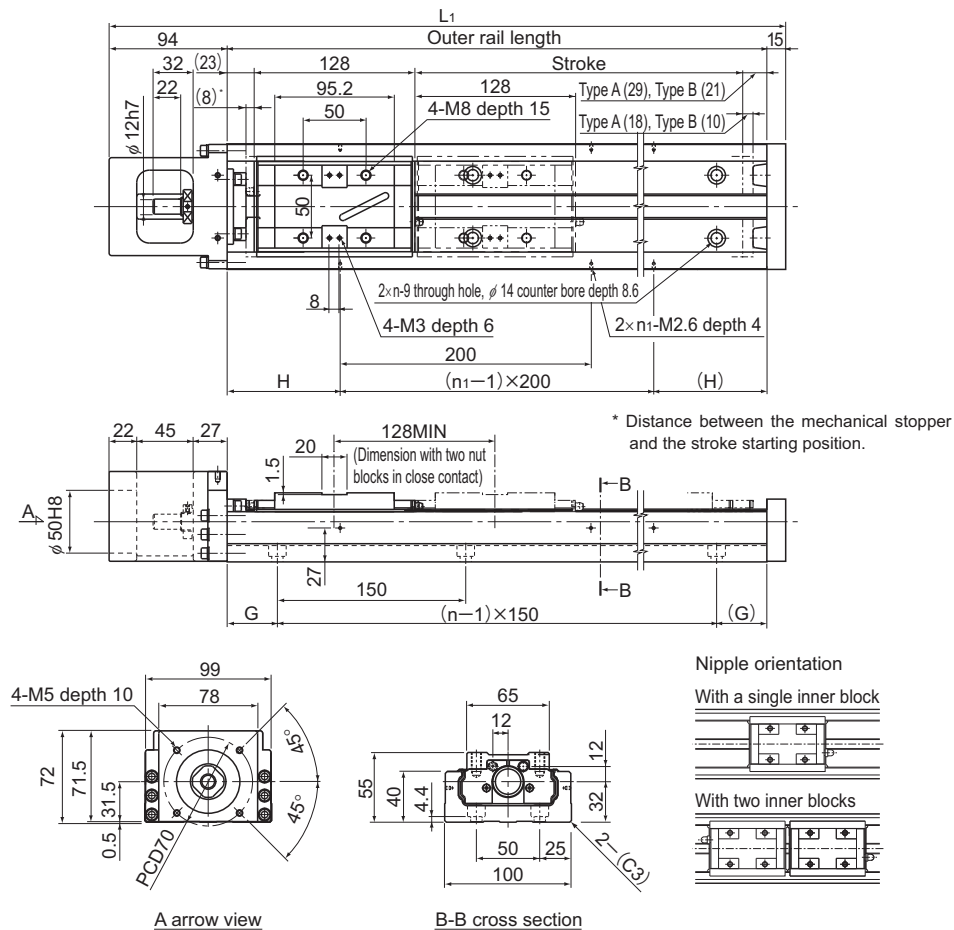

Stroke (mm) (stroke between mechanical stoppers)		Outer rail length (mm)	Overall length L_1 (mm)	H (mm)	G (mm)	n	n_1	Overall main unit mass (kg)	
Type A	Type B*							Type A	Type B
800(826)	680(698)	980	1089	90	40	7	5	19.9	21.6
900(926)	780(798)	1080	1189	40	15	8	6	21.7	23.4
1000(1026)	880(898)	1180	1289	90	65	8	6	23.4	25.1
1100(1126)	980(998)	1280	1389	40	40	9	7	25.1	26.8
1200(1226)	1080(1098)	1380	1489	90	15	10	7	26.9	28.6

*Indicates a value when two inner blocks are in close contact with each other.

Model KR55 (with a Cover)

Model KR5520A (with a Single Long Nut Block)

Model KR5520B (with Two Long Nut Blocks)

For model number coding, see **A2-96**.

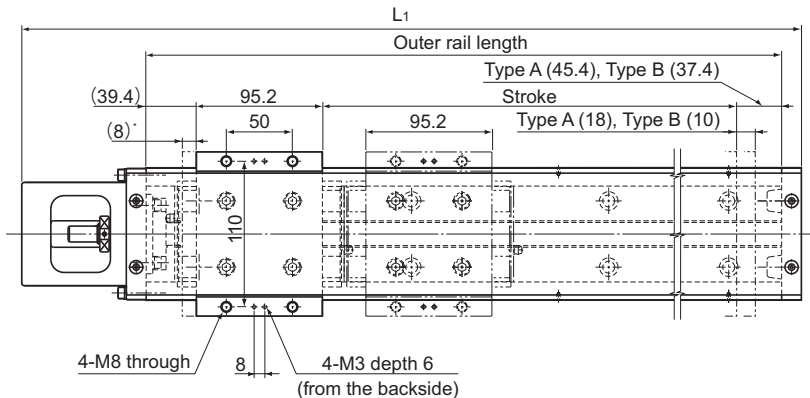

* Distance between the mechanical stopper and the stroke starting position.

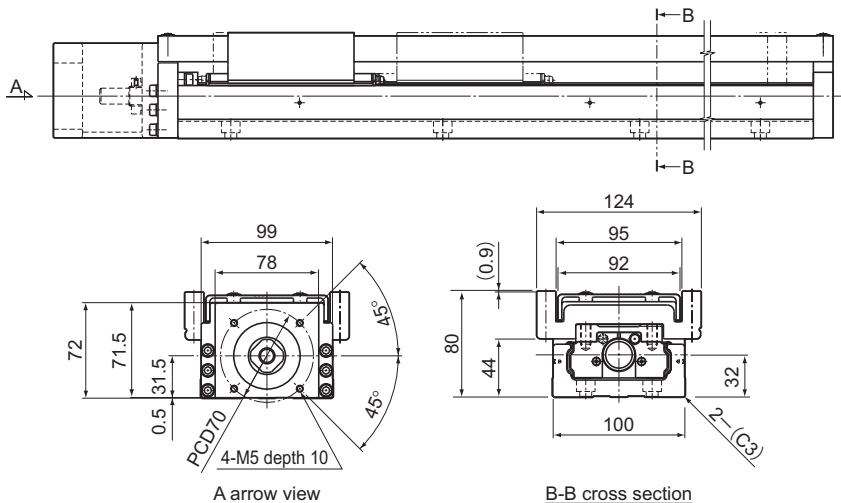

Stroke (mm) (stroke between mechanical stoppers)		Outer rail length (mm)	Overall length L_1 (mm)	Overall main unit mass (kg)	
Type A	Type B*			Type A	Type B
800(826)	680(698)	980	1089	22.7	26.2
900(926)	780(798)	1080	1189	24.6	28.1
1000(1026)	880(898)	1180	1289	26.4	29.9
1100(1126)	980(998)	1280	1389	28.1	31.6
1200(1226)	1080(1098)	1380	1489	30	33.5

*Indicates a value when two inner blocks are in close contact with each other.

Model KR65 Standard Type

Model KR6525A (with a Single Long Nut Block)

Model KR6525B (with Two Long Nut Blocks)

For model number coding, see **A2-96**.

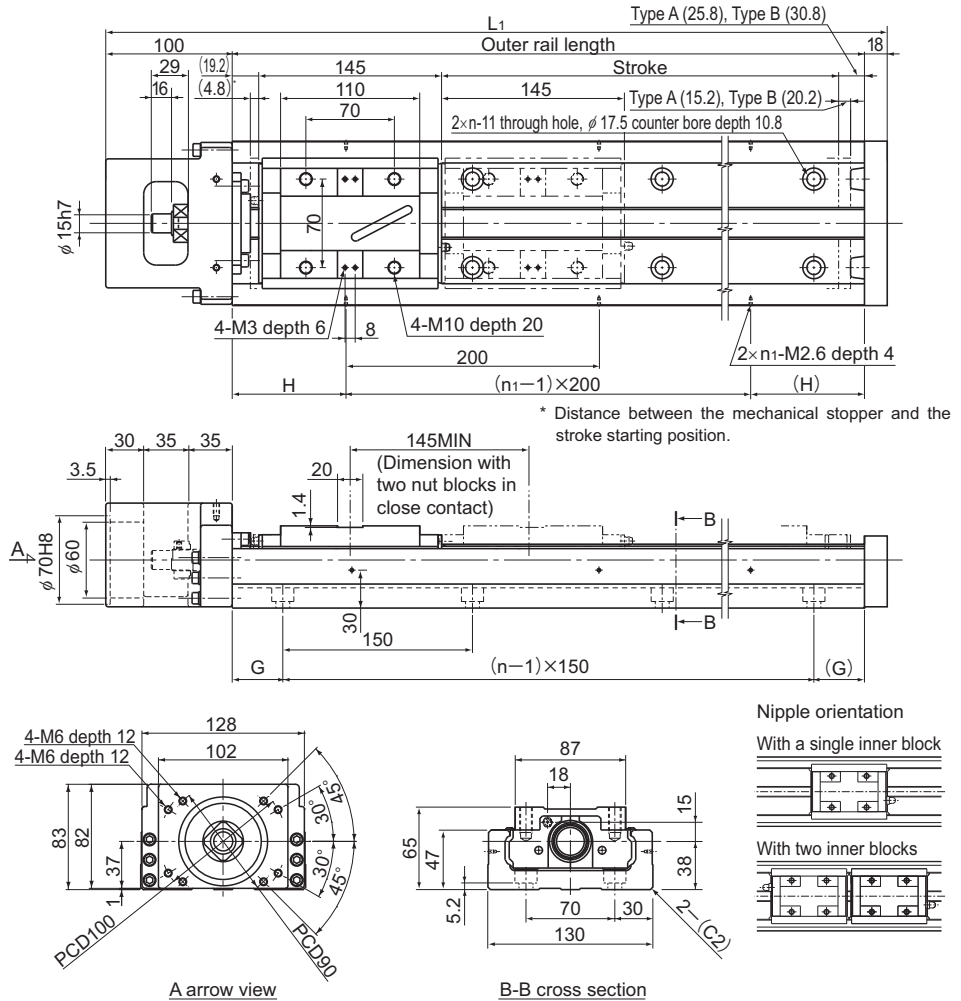

Stroke (mm) (stroke between mechanical stoppers)		Outer rail length (mm)	Overall length L_1 (mm)	H (mm)	G (mm)	n	n_1	Overall main unit mass (kg)	
Type A	Type B'							Type A	Type B
790(810)	640(665)	980	1098	90	40	7	5	31.6	34.6
990(1010)	840(865)	1180	1298	90	65	8	6	37	40
1190(1210)	1040(1065)	1380	1498	90	90	9	7	42.4	45.4
1490(1510)	1340(1365)	1680	1798	40	90	11	9	50.5	53.5

*Indicates a value when two inner blocks are in close contact with each other.

Model KR65 (with a Cover)

Model KR6525A (with a Single Long Nut Block)

Model KR6525B (with Two Long Nut Blocks)

For model number coding, see **A2-96**.

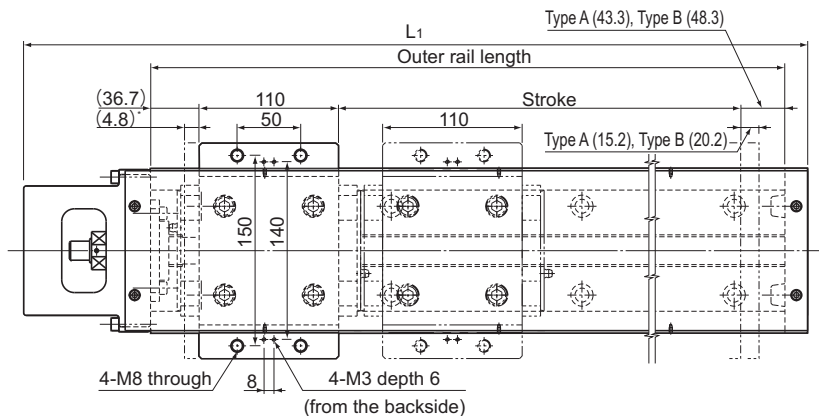

* Distance between the mechanical stopper and the stroke starting position.

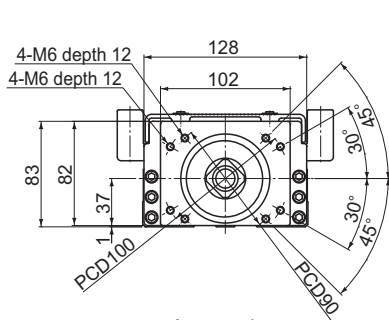
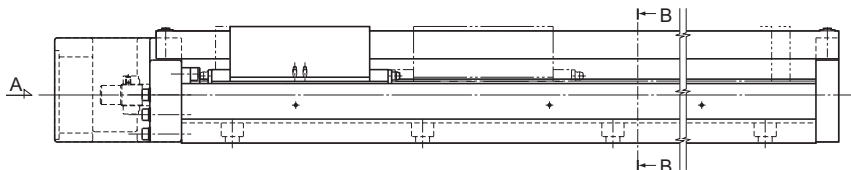

A arrow view

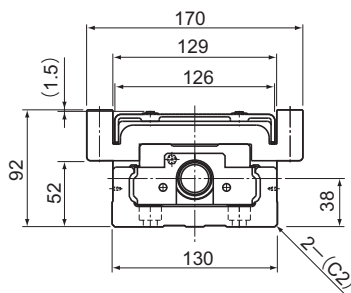

B-B cross section

Stroke (mm) (stroke between mechanical stoppers)		Outer rail length (mm)	Overall length L ₁ (mm)	Overall main unit mass (kg)	
Type A	Type B			Type A	Type B
790(810)	640(665)	980	1098	36.3	43
990(1010)	840(865)	1180	1298	42	48.7
1190(1210)	1040(1065)	1380	1498	47.6	54.3
1490(1510)	1340(1365)	1680	1798	56.1	62.8

*Indicates a value when two inner blocks are in close contact with each other.

Mass of Moving Element

Table13 shows the mass of the inner block and top table of model KR.

Table13 Mass of the Inner Block and Top table of KR

Unit: kg

Model No.	Long nut block types (A)		Short nut block types (C)	
	Inner block	Top table	Inner block	Top table
KR15	0.042	0.022	—	—
KR20	0.075	0.045	—	—
KR26	0.180	0.085	—	—
KR30H	0.30	0.13	0.17	0.07
KR33	0.35	0.13	0.23	0.07
KR45H	0.95	0.36	0.53	0.19
KR46	1.20	0.29	0.80	0.19
KR55	1.70	1.80	—	—
KR65	3.00	3.70	—	—

Bellows

For model KR, bellows are available for contamination protection in addition to a cover.

[Model KR-A (with a Single Long Nut Block)]

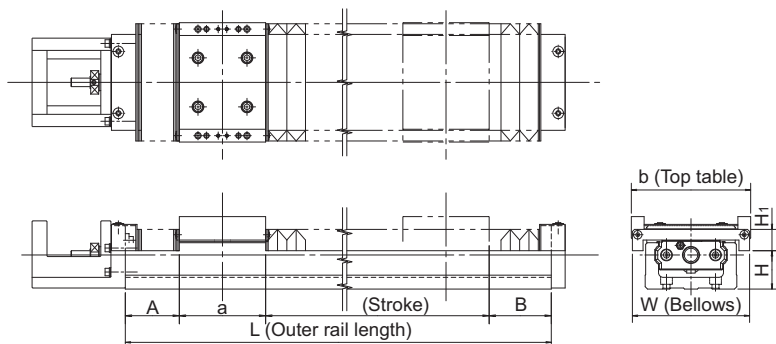

Unit: mm

Model No.	Stroke ¹⁾	Outer rail length L	A	B	a	b	W	H	H _i
KR15	15(22.2)	75	15.8	14	23	44	49	8	15.5
	30(37.2)	100	20.8	19					
	45(52.2)	125	25.8	24					
	60(67.2)	150	30.8	29					
	75(82.2)	175	35.8	34					
90(97.2)	200	40.8	39						
KR20	20(30.8)	100	18.8	17.2	33.2	52	60	10	20
	55(67.8)	150	25.3	23.7					
	80(93.6)	200	37	36.2					
KR26	50(61.3)	150	23.7	17.6	47.4	62	74	18	20
	80(91.6)	200	32.8	28.2					
	110(125.6)	250	40.8	36.2					
	160(175.6)	300	40.8	36.2					
KR30H	30(42)	150	28.5	25.5	54	80	80	21.5	17.5
	60(72)	200	38.5	35.5					
	130(142)	300	53.5	50.5					
	200(212)	400	68.5	65.5					
	270(282)	500	83.5	80.5					
340(352)	600	98.5	95.5						
KR33	30(42)	150	28.4	25.6	54	86	84	24.5	20
	70(82)	200	33.4	30.6					
	150(162)	300	43.4	40.6					
	220(232)	400	58.4	55.6					
	300(312)	500	68.4	65.6					
	370(382)	600	83.4	80.6					
450(462)	700	93.4	90.6						

Model No.	Stroke*1	Outer rail length L	A	B	a	b	W	H	H ₁
KR45H	160(177)	340	41.1	40.9	81	104	104	28	28
	240(255)	440	52.1	51.9					
	320(339)	540	60.1	59.9					
	400(423)	640	68.1	67.9					
	470(491)	740	84.1	83.9					
	550(575)	840	92.1	91.9					
KR46	640(659)	940	100.1	99.9	81	112	110	36	20
	140(155)	340	52.9	51.1					
	210(225)	440	67.9	66.1					
	290(305)	540	77.9	76.1					
	360(375)	640	92.9	91.1					
	440(455)	740	102.9	101.1					
KR55	510(525)	840	117.9	116.1	95.2	124	154	37	40
	590(605)	940	127.9	126.1					
	700(719.6)	980	84.6	80.6					
	790(809.6)	1080	89.6	85.6					
	870(889.6)	1180	99.6	95.6					
KR65	960(979.6)	1280	104.6	100.6	110	170	184	40	47
	1050(1069.6)	1380	109.6	105.6					
	680(703.2)	980	85.1	81.7					
	860(883.2)	1180	95.1	91.7					
	1030(1053.2)	1380	110.1	106.7					
	1290(1313.2)	1680	130.1	126.7					

*1 The value in the parentheses represents the maximum stroke.

*2 The bellows for KR55 and KR65 are only suitable for horizontal orientation. If the bellows is to be used in other orientations (vertical or wall-mounted), contact THK.

[Model KR-B (with Two Long Nut Blocks)]

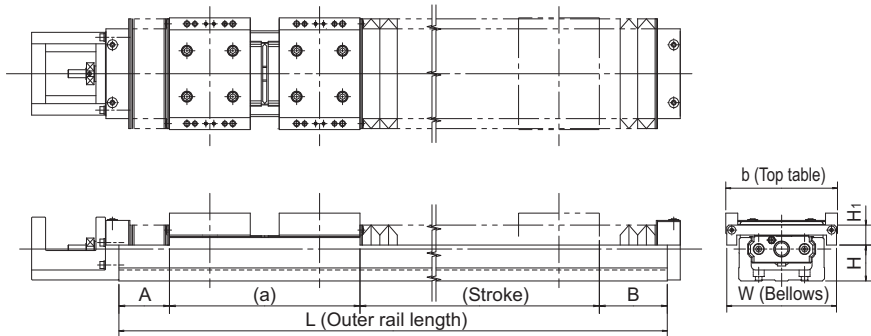

Unit: mm

Model No.	Stroke ^{1,2}	Outer rail length L	A	B	a	b	W	H	H ₁
KR15	20(29.2)	125	20.8	19	56	44	49	8	15.5
	35(44.2)	150	25.8	24					
	50(59.2)	175	30.8	29					
	65(74.2)	200	35.8	34					
KR20	25(34.8)	150	18.8	17.2	79.2	52	60	10	20
	60(71.8)	200	25.3	23.7					
KR26	35(47.3)	200	23.7	17.6	111.4	62	74	18	20
	65(77.6)	250	32.8	28.2					
	115(127.6)	300	32.8	28.2					
KR30H	85(97.6)	300	38.5	35.5	128.4	80	80	21.5	17.5
	155(167.6)	400	53.5	50.5					
	225(237.6)	500	68.5	65.5					
	295(307.6)	600	83.5	80.5					
KR33	80(96)	300	38.4	35.6	130	86	84	24.5	20
	160(176)	400	48.4	45.6					
	240(256)	500	58.4	55.6					
	310(326)	600	73.4	70.6					
	390(406)	700	83.4	80.6					
KR45H	80(95)	340	28.1	27.9	189	104	104	28	28
	155(170.5)	440	41.1	39.4					
	230(247)	540	52.1	51.9					
	310(331)	640	60.1	59.9					
	400(415)	740	68.1	67.9					
	465(483)	840	84.1	83.9					
KR46	550(567)	940	92.1	91.9	191	112	110	36	20
	60(75)	340	37.9	36.1					
	130(145)	440	52.9	51.1					
	210(225)	540	62.9	61.1					
	280(295)	640	77.9	76.1					
	360(375)	740	87.9	86.1					
	430(445)	840	102.9	101.1					
510(525)	940	112.9	111.1						

Model No.	Stroke ^{*1,2}	Outer rail length L	A	B	a	b	W	H	H ₁
KR55	590(612)	980	74.6	70.6	222.8	124	154	37	40
	670(692)	1080	84.6	80.6					
	760(782)	1180	89.6	85.6					
	850(872)	1280	94.6	90.6					
	930(952)	1380	104.6	100.6					
KR65	550(578.6)	980	75.1	71.7	254.6	170	184	40	47
	720(748.6)	1180	90.1	86.7					
	900(928.6)	1380	100.1	96.7					
	1160(1188.6)	1680	120.1	116.7					

*1 The strokes in the table are values when the blocks are in close contact with each other.

*2 The value in the parentheses represents the maximum stroke.

*3 The bellows for KR55 and KR65 are only suitable for horizontal orientation. If the bellows is to be used in other orientations (vertical or wall-mounted), contact THK.

Note) The bellows cannot be attached between the top tables.

[Model KR-C (with a Single Short Nut Block)]

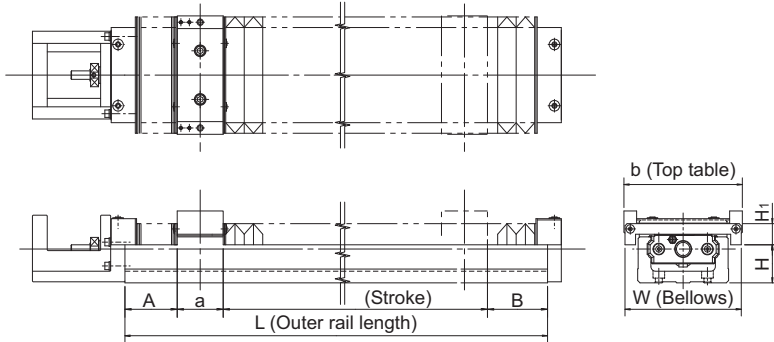

Unit: mm

Model No.	Stroke*	Outer rail length L	A	B	a	b	W	H	H ₁
KR30H	45(57.5)	150	33.5	30.5	28.5	80	80	21.5	17.5
	85(97.5)	200	38.5	35.5					
	155(167.5)	300	53.5	50.5					
	225(237.5)	400	68.5	65.5					
	295(307.5)	500	83.5	80.5					
365(377.5)	600	98.5	95.5						
KR33	55(67.5)	150	28.4	25.6	28.5	86	84	24.5	20
	95(107.5)	200	33.4	30.6					
	165(177.5)	300	48.4	45.6					
	245(257.5)	400	58.4	55.6					
	315(327.5)	500	73.4	70.6					
395(407.5)	600	83.4	80.6						
465(477.5)	700	98.4	95.6						
KR45H	190(208.5)	340	44.1	43.9	43.5	104	104	28	28
	275(292.5)	440	52.1	51.9					
	340(360.5)	540	68.1	67.9					
	425(444.5)	640	76.1	75.9					
	510(528.5)	740	84.1	83.9					
	580(596.5)	840	100.1	99.9					
660(680.5)	940	108.1	107.9						
KR46	170(182.5)	340	57.9	56.1	43.5	112	110	36	20
	240(252.5)	440	72.9	71.1					
	320(332.5)	540	82.9	81.1					
	390(402.5)	640	97.9	96.1					
	470(482.5)	740	107.9	106.1					
	540(552.5)	840	122.9	121.1					
620(632.5)	940	132.9	131.1						

*The value in the parentheses represents the maximum stroke.

[Model KR-D (with Two Short Nut Blocks)]

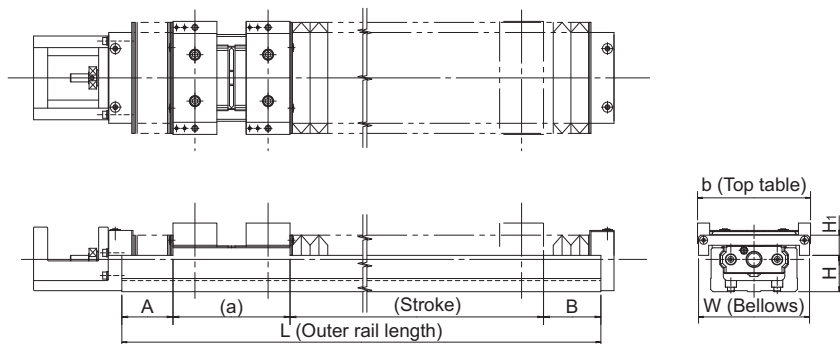

Unit: mm

Model No.	Stroke ^{*1,2}	Outer rail length L	A	B	a	b	W	H	H ₁
KR30H	15(28.6)	150	23.5	20.5	77.4	80	80	21.5	17.5
	45(58.6)	200	33.5	30.5					
	115(128.6)	300	48.5	45.5					
	185(198.6)	400	63.5	60.5					
	255(268.6)	500	78.5	75.5					
325(338.6)	600	93.5	90.5						
KR33	55(67)	200	28.4	25.6	79	86	84	24.5	20
	125(137)	300	43.4	40.6					
	205(217)	400	53.4	50.6					
	275(287)	500	68.4	65.6					
	355(367)	600	78.4	75.6					
425(437)	700	93.4	90.6						
KR45H	140(154)	340	36.1	35.9	114	104	104	28	28
	220(238)	440	44.1	43.9					
	290(306)	540	60.1	59.9					
	370(390)	640	68.1	67.9					
	455(474)	740	76.1	75.9					
	525(542)	840	92.1	91.9					
605(626)	940	100.1	99.9						
KR46	110(130)	340	47.9	46.1	116	112	110	36	20
	180(200)	440	62.9	61.1					
	260(280)	540	72.9	71.1					
	330(350)	640	87.9	86.1					
	410(430)	740	97.9	96.1					
	480(500)	840	112.9	111.1					
560(580)	940	122.9	121.1						

*1 The strokes in the table are values when the blocks are in close contact with each other.

*2 The value in the parentheses represents the maximum stroke.

Note) The bellows cannot be attached between the top tables.

Sensor

Optional photo sensors and proximity sensors are available for KR models.

[Example of Installation]

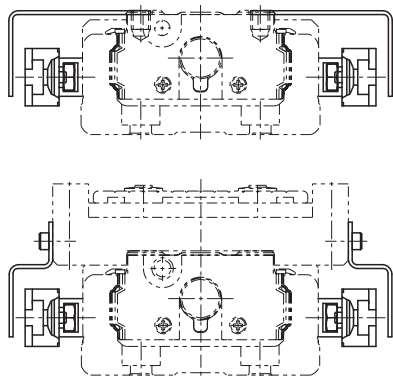

Table14 With/without a sensor

Symbol	Description	Type	Accessory *1
0	None	—	—
1	With sensor rail	—	Mounting screws, sensor rail
2	Photo Sensor ² [3 units]	EE-SX671 (Omron Corp.)	Mounting screw/nut, detecting plate, sensor rail, mounting plate, connector (EE-1001)
6	Photo Sensor ² [3 units]	EE-SX674 (Omron Corp.)	Mounting screw/nut, detecting plate, sensor rail, mounting plate, connector (EE-1001)
7	Proximity Sensor N.O. contact [3 units]	APM-D3A1-001 (Azbil Corp.)	Mounting screw/nut, detecting plate, sensor rail
B	Proximity Sensor N.C. contact [3 units]	APM-D3B1-003 (Azbil Corp.)	Mounting screw/nut, detecting plate, sensor rail
E	Proximity Sensor N.O. contact [1 unit] N.C. contact [2 units]	APM-D3A1-001 APM-D3B1-003 (Azbil Corp.)	Mounting screw/nut, detecting plate, sensor rail
H	Proximity Sensor N.O. contact [3 units]	GX-F12A (Panasonic Industrial Devices SUNX Co., Ltd.)	Mounting screw/nut, detecting plate, sensor rail
L	Proximity Sensor N.C. contact [3 units]	GX-F12B (Panasonic Industrial Devices SUNX Co., Ltd.)	Mounting screw/nut, detecting plate, sensor rail
J	Proximity Sensor N.O. contact [1 unit] N.C. contact [2 units]	GX-F12A GX-F12B (Panasonic Industrial Devices SUNX Co., Ltd.)	Mounting screw/nut, detecting plate, sensor rail
M	Proximity Sensor N.O. contact [1 unit] N.C. contact [2 units]	GX-F12A-P GX-F12B-P (Panasonic Industrial Devices SUNX Co., Ltd.)	Mounting screw/nut, detecting plate, sensor rail

N.O. contact: normally open contact

N.C. contact: normally closed contact

*1 If the stroke is less than 70 mm, 2 sensor flags and 2 sensor rails will be included. KR15, 20 and 26 ship with sensor rails already installed.

*2 The photo-sensors can be switched between ON when lit and ON when unlit.

[Proximity Sensor]

APM-D3A1-001 (Azbil Corp.)	3 units	GX-F12B (Panasonic Industrial Devices SUNX Co., Ltd.)	3 units
APM-D3B1-003 (Azbil Corp.)	3 units	GX-F12A-P (Panasonic Industrial Devices SUNX Co., Ltd.)	3 units
GX-F12A (Panasonic Industrial Devices SUNX Co., Ltd.)	3 units	GX-F12B-P (Panasonic Industrial Devices SUNX Co., Ltd.)	3 units

● Proximity Sensor: APM-D3A1-001 APM-D3B1-003 (Azbil Corp.)

Unit: mm

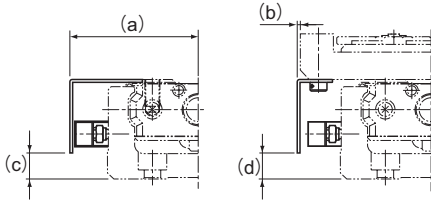

Model No.	a	b	c	d
KR15	27.8	5.8	1.4	1.4
KR20	32.5	6.6	6	6
KR26	37	6.4	8	8
KR30H	43.3	3.3	8.8	9
KR33	42.5	-0.6	8.8	9
KR45H	53.2	1.2	14	14
KR46	55.4	-0.6	21.8	22
KR55	62.4	0.4	22	22
KR65	77.4	-7.6	25.1	25

● Proximity sensor GX-F12A GX-F12B GX-F12A-P
GX-F12B-P (Panasonic Industrial Devices SUNX Co., Ltd.)

Unit: mm

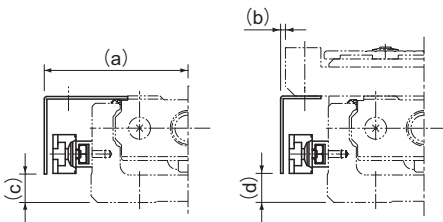

Model No.	a	b	c	d
KR20	34	8.1	3.6	4
KR26	38.5	7.9	6	6
KR30H	45	5	8.8	9
KR33	44.5	1.5	8.8	9
KR45H	54.8	2.8	13.8	14
KR46	57.5	1.5	21.8	22
KR55	64.5	2.5	22	22
KR65	79	-6	25.1	25

[Photo Sensor]

EE-SX671 (Omron Corp.) 3 units

EE-SX674 (Omron Corp.) 3 units

Connector EE-1001 (Omron Corp.) 3 units

(Note) The connector is an appended article.

● Photo Sensor: EE-SX671 (Omron Corp.)

Unit: mm

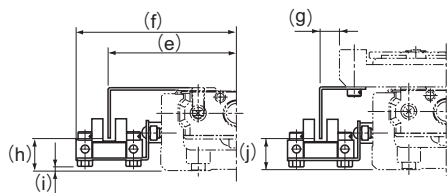

Model No.	e	f	g	h	i	j
KR20	41.3	53.8	15	9.4	0.9	9.5
KR26	46	58.7	14.9	11.4	2.9	11.5
KR30H	51.3	63.9	11.3	13.8	1.4	13.5
KR33	50.8	63.7	7.7	12.8	2.2	13
KR45H	61.2	73.8	9.3	18.3	6.4	18.5
KR46	63.6	76.6	7.7	25.8	15.2	26
KR55	70.7	83.5	8.6	24.5	13.6	25
KR65	85.5	98.5	0.6	28.1	16.6	28

● Photo Sensor: EE-SX674 (Omron Corp.)

Unit: mm

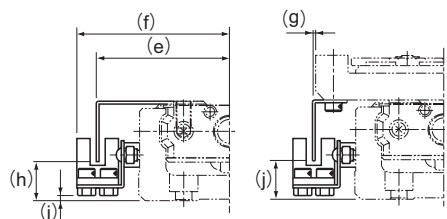

Model No.	e	f	g	h	i	j
KR20	38.3	44.8	12.5	10.9	0.6	11
KR26	43.5	49.7	12.5	12.9	2.6	13
KR30H	46.2	52.4	6.3	13.8	1.1	14
KR33	44.5	50.7	1.5	12.8	1.7	13
KR45H	56.2	62.3	4.2	19	6.1	19
KR46	57.5	63.6	1.5	25.8	14.1	26
KR55	63.5	70.5	1.5	24.5	13.1	24
KR65	79	85.5	-6	28.6	16.1	28

[Sensor Rail]

The sensor rail can be attached alone.

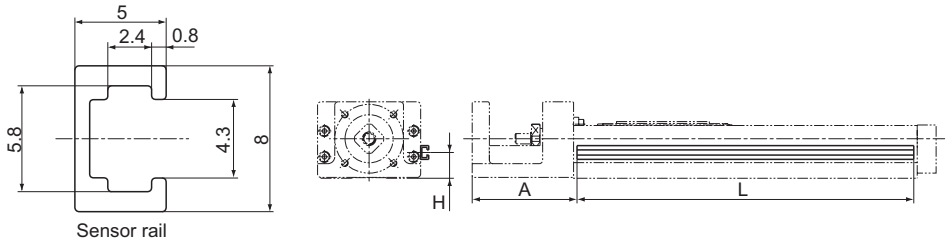

Sensor rail

Unit: mm

Model No.	Stroke*	Outer rail length	H	A	L
KR15	25	75	5.5	37.5	88
	50	100			113
	75	125			138
	100	150			163
	125	175			188
	150	200			213
KR20	30	100	10	43	111
	80	150			161
	130	200			211
KR26	60	150	12	54	161
	110	200			211
	160	250			261
	210	300			311
KR30H	50	150	14	61	146
	100	200			196
	200	300			296
	300	400			396
	400	500			496
	500	600			596
KR33	50	150	15	61	146
	100	200			196
	200	300			296
	300	400			396
	400	500			496
	500	600			596
	600	700			696
KR45H	200	340	19	90	336
	300	440			436
	400	540			536
	500	640			636
	600	740			736
	700	840			836
	800	940			936

Unit: mm

Model No.	Stroke*	Outer rail length	H	A	L
KR46	190	340	28	89.5	336
	290	440			436
	390	540			536
	490	640			636
	590	740			736
	690	840			836
	790	940			936
	800	980			976
KR55	900	1080	27	96	1076
	1000	1180			1176
	1100	1280			1276
	1200	1380			1376
KR65	790	980	30	102	976
	990	1180			1176
	1190	1380			1376
	1490	1680			1676

*Indicates stroke length when one long-type inner block is incorporated.

Housing

THK also offers Housing A provided with a separate motor, and a turnaround type of Housing A, as options in order to support a motor bracket or a turnaround section that the customer may separately produce.

[Housing A for a Separate Motor]

By using the fitting difference, the user can easily mount a separately manufactured motor bracket.

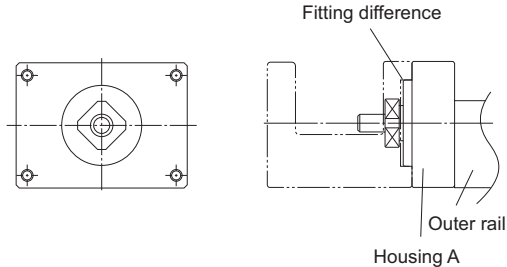

[Turnaround Housing A]

Since the mounting holes are drilled in constant pitches, the user can easily select a direction to mount the turnaround section.

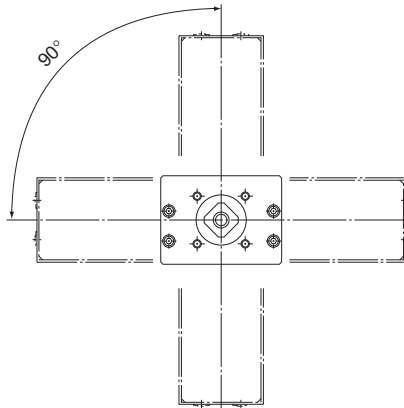

Intermediate Flange

[Motor Used and Applicable Intermediate Flanges for Model KR]

Several types of intermediate flanges for mounting motors are available for model KR. Specify an intermediate flange that matches the motor used.

Each intermediate flange is made of steel and provided with THK AP-C treatment, a surface treatment that provides excellent corrosion resistance.

Table15 Table of Motors Used and Corresponding Intermediate Flanges

Motor type		Rated output	Flange size	KR15	KR20	KR26	KR30H	KR33	KR45H	KR46	KR55	KR65			
AC servo motor	Yaskawa Electric	Σ-V	SGMMV-A1	10W	□25	AN	AN	AN	—	—	—	—			
			SGMMV-A2	20W		AN	AN	AN	—	—	—	—	—		
			SGMMV-A3	30W		—	AN	AN	—	—	—	—	—		
		SGMJV-A5	50W	□40	—	AQ	AQ	AQ	AQ	AQ	AQ	—	—		
		SGMAV-A5			—	AQ	AQ	AQ	AQ	AQ	AQ	—	—		
		SGMJV-01	100W	□40	—	—	—	AQ	AQ	AQ	AQ	—	—		
		SGMAV-01			—	—	—	AQ	AQ	AQ	AQ	—	—		
		SGMJV-C2	150W	□40	—	—	—	AQ	AQ	AQ	AQ	—	—		
		SGMJV-02	200W	□60	—	—	—	—	—	A0	40	A0	AV		
		SGMAV-02			—	—	—	—	—	A0	40	A0	AV		
		SGMJV-04	400W	□60	—	—	—	—	—	A0	40	A0	AV		
		SGMAV-04			—	—	—	—	—	A0	40	A0	AV		
		SGMJV-06	550W	□60	—	—	—	—	—	A0	40	A0	AV		
		SGMJV-08	750W	□80	—	—	—	—	—	—	—	—	AZ	AZ	
	SGMAV-08	—			—	—	—	—	—	—	—	AZ	AZ		
	Mitsubishi Electric	MELSERVO	Σ-7	SGM7J-A5	50W	□40	—	AQ	AQ	AQ	AQ	AQ	—	—	
				SGM7A-A5			—	AQ	AQ	AQ	AQ	AQ	AQ	—	—
				SGM7J-01	100W	□40	—	AQ	AQ	AQ	AQ	AQ	AQ	—	—
				SGM7A-01			—	AQ	AQ	AQ	AQ	AQ	AQ	—	—
				SGM7J-C2	150W	□40	—	AQ	AQ	AQ	AQ	AQ	AQ	—	—
				SGM7J-02	200W	□60	—	—	—	—	—	A0	40	A0	AV
				SGM7A-02			—	—	—	—	—	A0	40	A0	AV
			SGM7J-04	400W	□60	—	—	—	—	—	A0	40	A0	AV	
			SGM7A-04			—	—	—	—	—	A0	40	A0	AV	
			SGM7J-06	550W	□60	—	—	—	—	—	A0	40	A0	AV	
			SGM7J-08	750W	□80	—	—	—	—	—	—	—	—	AZ	AZ
			SGM7A-08			—	—	—	—	—	—	—	—	AZ	AZ
			Mitsubishi Electric	MELSERVO	J3	HF-MP053	50W	□40	—	AQ	AQ	AQ	AQ	AQ	—
HF-KP053						—			AQ	AQ	AQ	AQ	AQ	AQ	—
HF-MP13	100W	□40				—	—	—	AQ	AQ	AQ	AQ	—	—	
HF-KP13						—	—	—	AQ	AQ	AQ	AQ	—	—	
HF-MP23	200W	□60				—	—	—	—	—	A0	40	A0	AV	
HF-KP23						—	—	—	—	—	A0	40	A0	AV	
HF-MP43	400W	□60				—	—	—	—	—	A0	40	A0	AV	
HF-KP43					—	—	—	—	—	A0	40	A0	AV		
HF-MP73	750W	□80			—	—	—	—	—	—	—	AZ	AZ		
HF-KP73					—	—	—	—	—	—	—	AZ	AZ		
Mitsubishi Electric	MELSERVO	J4			HG-AK0136	10W	□25	AN	AN	AN	—	—	—	—	
					HG-AK0236	20W		AN	AN	AN	—	—	—	—	
					HG-AK0336	30W		—	AN	AN	—	—	—	—	
		HG-MR053			50W	□40	—	AQ	AQ	AQ	AQ	AQ	AQ	—	—
		HG-KR053					—	AQ	AQ	AQ	AQ	AQ	AQ	—	—
		HG-MR13			100W	□40	—	—	—	AQ	AQ	AQ	AQ	—	—
		HG-KR13					—	—	—	AQ	AQ	AQ	AQ	—	—
		HG-MR23	200W	□60	—	—	—	—	—	A0	40	A0	AV		
		HG-KR23			—	—	—	—	—	A0	40	A0	AV		
		HG-MR43	400W	□60	—	—	—	—	—	A0	40	A0	AV		
HG-KR43	—	—			—	—	—	A0	40	A0	AV				

AC servo motor		Motor type		Rated output	Flange size	KR15	KR20	KR26	KR30H	KR33	KR45H	KR46	KR55	KR65				
		Mitsubishi Electric																
SANYO DENKI	SANMOTION R	MELSERVO	J4	HG-MR73	750W	□80	—	—	—	—	—	—	—	AZ	AZ			
			HG-KR73	—			—	—	—	—	—	—	—	AZ	AZ			
			JN	HF-KN053	50W	□40	—	AQ	AQ	AQ	AQ	AQ	AQ	—	—	—	—	
			HF-KN13	100W	—	—	—	AQ	AQ	AQ	AQ	AQ	AQ	—	—	—	—	
			HF-KN23	200W	□60	—	—	—	—	—	—	A0	40	A0	A0	AV	AV	
		HF-KN43	400W	—	—	—	—	—	—	—	A0	40	A0	A0	AV	AV		
		Tamagawa Seiki Co., Ltd.	TBL-iII	TBL-iIV	TS4602	50W	□40	—	AQ	AQ	AQ	AQ	AQ	AQ	AQ	—	—	
					TS4603	100W		—	—	—	AQ	AQ	AQ	AQ	AQ	—	—	
					TS4604	150W	—	—	—	AQ	AQ	AQ	AQ	AQ	—	—	—	—
					TS4607	200W	□60	—	—	—	—	—	—	A0	40	A0	A0	AV
TS4609	400W				—	—	—	—	—	—	—	A0	40	A0	A0	AV		
TS4614	750W				□80	—	—	—	—	—	—	—	—	—	AZ	AZ		
TSM3101	30W				□40	—	AQ	AQ	—	—	—	—	—	—	—	—	—	
TSM3102	50W					—	AQ	AQ	AQ	AQ	AQ	AQ	AQ	—	—	—	—	
TSM3104	100W				—	—	—	AQ	AQ	AQ	AQ	AQ	AQ	—	—	—	—	
TSM3202	200W				□60	—	—	—	—	—	—	—	A0	40	A0	A0	AV	
TSM3204	400W	—	—	—		—	—	—	A0	40	A0	A0	AV	AV				
TSM3303	600W	□80	—	—	—	—	—	—	—	—	—	—	AZ	AZ				
TSM3304	750W		—	—	—	—	—	—	—	—	—	—	AZ	AZ				
Panasonic Corp.	MINAS	A5	MSMD5A	50W	□38	—	AP	AP	AP	AP	AP	AP	AP	—	—			
			MSME5A	—		—	AP	AP	AP	AP	AP	AP	—	—				
			MSMD01	100W	□38	—	—	—	AP	AP	AP	AP	AP	—	—	—		
			MSME01	—		—	—	AP	AP	AP	AP	AP	—	—				
			MSMD02	200W	□60	—	—	—	—	—	—	AY	30	—	—	—		
		MSME02	—	—		—	—	—	—	—	AY	30	—	—	—			
		MSMD04	400W	□60	—	—	—	—	—	—	AY	30	—	—	—			
		MSME04	—		—	—	—	—	—	—	AY	30	—	—	—			
		MSMD08	750W	□80	—	—	—	—	—	—	—	—	—	A5	A5			
		MSME08	—		—	—	—	—	—	—	—	—	—	A5	A5			
Keyence Corporation	SV	SV-M005	50W	□40	—	AQ	AQ	AQ	AQ	AQ	AQ	AQ	—	—				
		SV-M010	100W		—	—	—	AQ	AQ	AQ	AQ	AQ	—	—				
		SV-M020	200W	□60	—	—	—	—	—	—	A0	40	A0	AV				
		SV-M040	400W		—	—	—	—	—	—	A0	40	A0	AV				
		SV-M075	750W	□80	—	—	—	—	—	—	—	—	AZ	AZ				
	SV2	SV2-M005	50W	□40	—	AQ	AQ	AQ	AQ	AQ	AQ	AQ	AQ	—	—			
		SV2-M010	100W		—	—	—	AQ	AQ	AQ	AQ	AQ	AQ	—	—			
		SV2-M020	200W	□60	—	—	—	—	—	—	A0	40	A0	AV				
		SV2-M040	400W		—	—	—	—	—	—	A0	40	A0	AV				
		SV2-M075	750W	□80	—	—	—	—	—	—	—	—	AZ	AZ				
SANYO DENKI	SANMOTION R	R2□A04003	30W	□40	—	AQ	AQ	—	—	—	—	—	—	—				
		R2□A04005	50W		—	AQ	AQ	AQ	AQ	AQ	AQ	AQ	—	—				
		R2EA04008	80W		—	—	—	AQ	AQ	AQ	AQ	AQ	—	—				
		R2□A04010	100W		—	—	—	AQ	AQ	AQ	AQ	AQ	—	—				
		R2□A06020	200W	□60	—	—	—	—	—	—	A0	40	A0	AV				
		R2AA06040	400W		—	—	—	—	—	—	A0	40	A0	AV				
		R2AA08075	750W		□80	—	—	—	—	—	—	—	—	AZ	AZ			

		Motor type		Rated output	Flange size	KR15	KR20	KR26	KR30H	KR33	KR45H	KR46	KR55	KR65	
AC servo motor	Omron	OMNUCG5	R88M-K05030	50W	□40	—	AQ	AQ	AQ	AQ	AQ	AQ	—	—	
			R88M-K10030	100W		—	—	—	AQ	AQ	AQ	AQ	—	—	
			R88M-K20030	200W	□60	—	—	—	—	—	AY	30	—	—	
			R88M-K40030	400W		—	—	—	—	AY	30	—	—		
		R88M-K75030	750W	□80	—	—	—	—	—	—	—	A5	A5		
		R88M-1M10030	100W	□40	—	—	—	AQ	AQ	AQ	AQ	—	—		
		R88M-1M20030	200W	□60	—	—	—	—	—	AY	30	—	—		
		R88M-1M40030	400W		—	—	—	—	AY	30	—	—			
	R88M-1M75030	750W	□80	—	—	—	—	—	—	—	A5	A5			
	Fanuc	β series	βis0.2/5000	50W	□40	—	AQ	AQ	AQ	AQ	AQ	AQ	AQ	—	—
			βis0.3/5000	100W		—	—	—	AQ	AQ	AQ	AQ	—	—	
	Stepping motor	Oriental Motor	αStep	AZ2 *, AR2 *	□28	AS	AS	AS	—	—	—	—	—	—	—
				AZ4 *, AR4 *	□42	—	AR	AR	AR	AR	—	—	—	—	—
				AZ6 *, AR6 *	□60	—	—	—	AU	AU	AU	10	—	—	
				AZ9 *, AR9 *	□85	—	—	—	—	—	—	—	—	A6	A6
				CRK52 *	□28	AS	AS	AS	—	—	—	—	—	—	—
CRK54 *			□42	—	AR	AR	AR	AR	—	—	—	—	—		
CRK56 *			□60	—	—	—	AU	AU	AU	10	—	—			
CSK II			CSK59 *	□85	—	—	—	—	—	—	—	—	A6	A6	
5 phase			RK II	RKS54 *	□42	—	AR	AR	AR	AR	—	—	—	—	—
				RKS56 *	□60	—	—	—	AU	AU	AU	10	—	—	
				RKS59 *	□85	—	—	—	—	—	—	—	—	A6	A6
			PKA	PKA544	□42	—	AR	AR	AR	AR	—	—	—	—	—
				PKA566	□60	—	—	—	AU	AU	AU	10	—	—	
CVK			CVK52 *	□28	AS	AS	AS	—	—	—	—	—	—	—	
			CVK54 *	□42	—	AR	AR	AR	AR	—	—	—	—	—	
			CVK56 *	□60	—	—	—	AU	AU	AU	10	—	—		
2 phase		CMK	CMK22 *	□28	AS	AS	AS	—	—	—	—	—	—	—	
			CMK24 *	□42	—	AR	AR	AR	AR	—	—	—	—		
			CMK26 *	□56.4	—	—	—	AT	AT	—	—	—	—		
		CVK	CVK22 *	□28	AS	AS	AS	—	—	—	—	—	—	—	
			CVK23 *	□35	—	—	—	—	—	—	—	—	—	—	
			CVK24 *	□42	—	AR	AR	AR	AR	—	—	—	—	—	
			CVK26 *	□56.4	—	—	—	AT	AT	—	—	—	—	—	
SANYO DENKI		PB	PBDM28 *	□28	AS	AS	AS	—	—	—	—	—	—	—	
			PBDM423, PBA * * 423	□42	—	AR	AR	AR	AR	—	—	—	—		
			PBDM60 *, PBA * * 60 *	□60	—	—	—	AU	AU	AU	10	—	—		
		5 phase	FAF/FDF52 *	□28	AS	AS	AS	—	—	—	—	—	—		
			FAF54 */FDF54 */ FA511M42/FB511M42	□42	—	AR	AR	AR	AR	—	—	—	—		
			FAM56 */FDM56 */ FA512M60/FA512M60	□60	—	—	—	AU	AU	AU	10	—	—		
		2 phase	D * 14S28 *	DB14H52 *	□28	AS	AS	AS	—	—	—	—	—	—	
				DU15H52 *	□42	—	AR	AR	AR	AR	—	—	—	—	
D * 16H71 *			D * 16H71 *	□56.4	—	—	—	AT	AT	—	—	—	—		
	DB16H78 *		□60	—	—	—	AU	AU	AU	10	—	—			
Keyence Corporation	2 phase	QS-M28	□28	AS	AS	AS	—	—	—	—	—	—			
		QS-M42	□42	—	AR	AR	AR	AR	—	—	—	—			
		QS-M60	□60	—	—	—	AU	AU	AU	10	—	—			

Note 1) The symbols in the table indicate the housing A and intermediate flange.

Note 2) For motor coupling, contact THK.

Note 3) The motor types in the table represent only some of the types available. For details regarding different types, please see the catalog from each respective motor manufacturer.

Note 4) Model KR15 has a limit in input torque. The permissible input torque for model KR1501 is 0.051 N·m at a maximum and that for model KR1502 is 0.103 N·m at a maximum. If the maximum torque of the motor mounted to model KR15 exceeds the permissible input torque, take a safety measure such as setting a torque limit.

[Dimensional Drawing of Housing A/Intermediate Flange for Model KR]

● For Model KR15

KR**	··· Actuator model number
●	··· ●: Housing A
◇	··· ◇: Intermediate Flange

■ Housing A

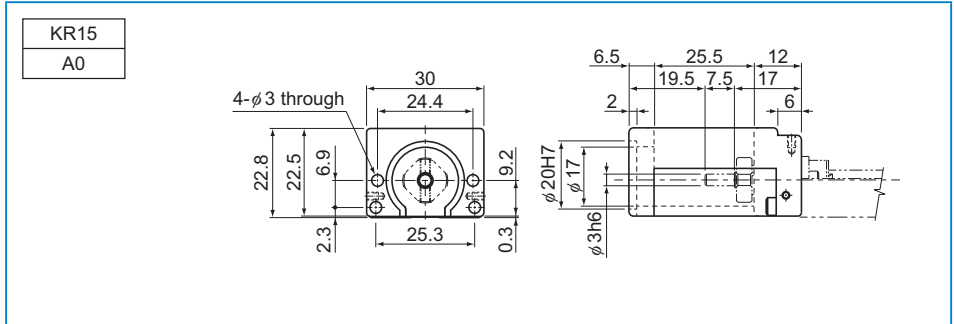

■ Intermediate Flange

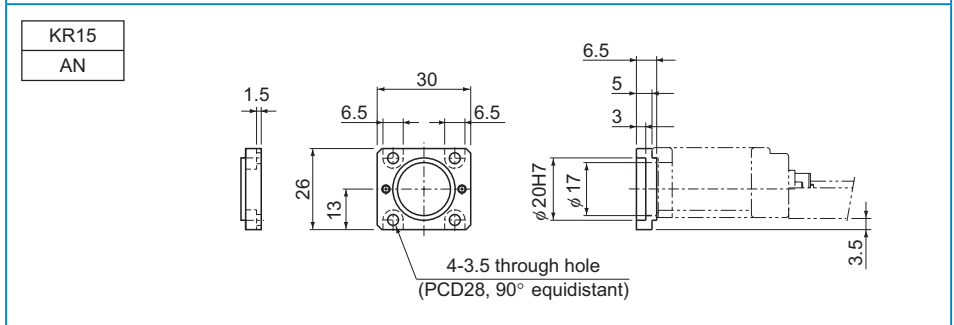
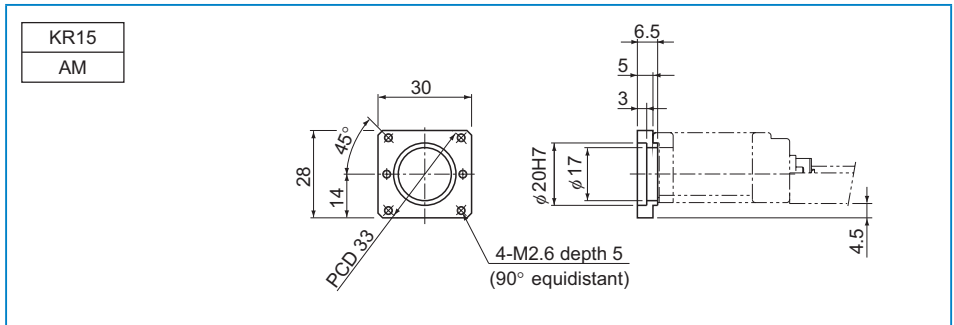

KR15
AS

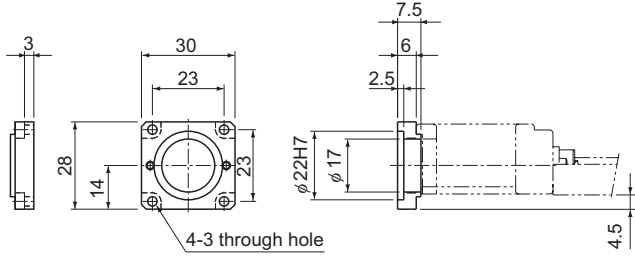

● For Model KR20

KR**	···· Actuator model number
●◇	····●: Housing A
	◇: Intermediate Flange

■ Housing A

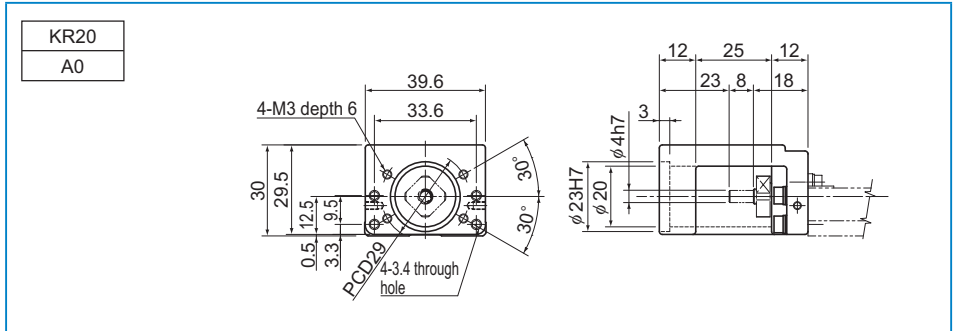

■ Intermediate Flange

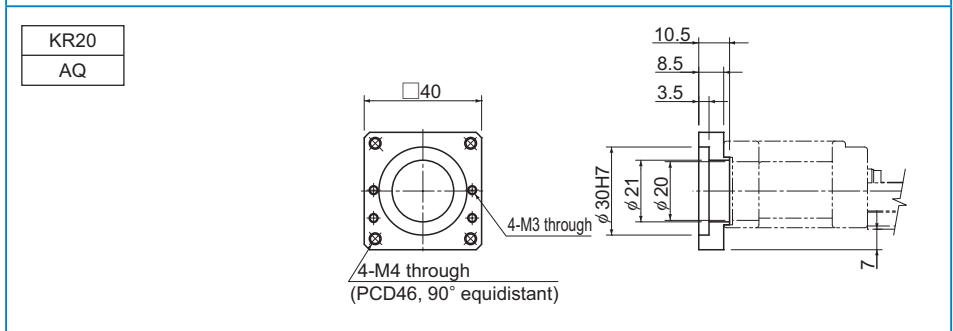
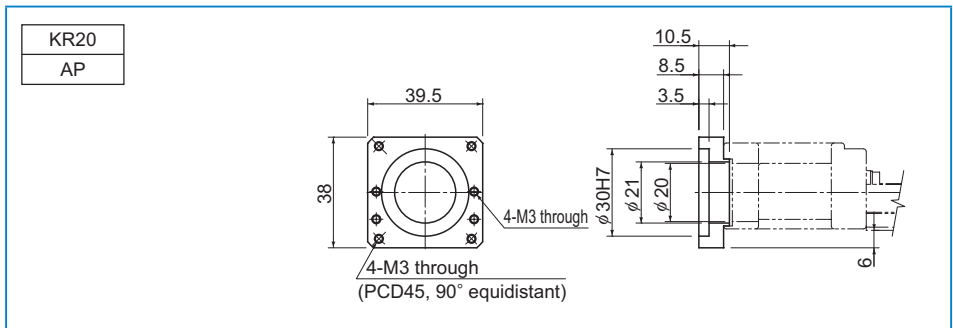

KR20

AR

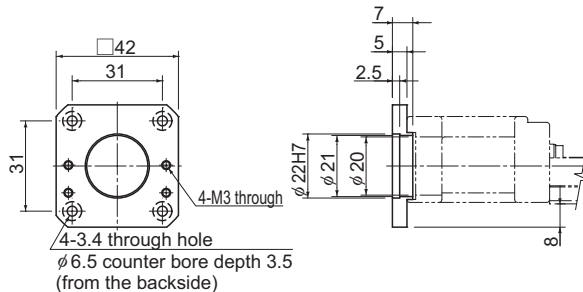

KR20

AS

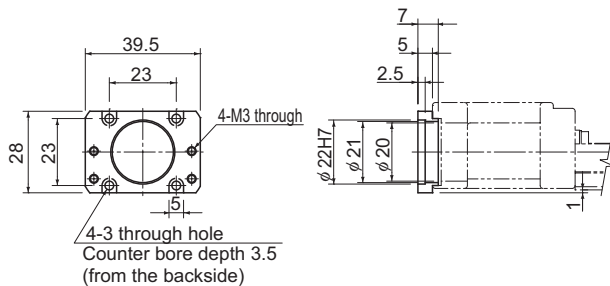

KR20

AM

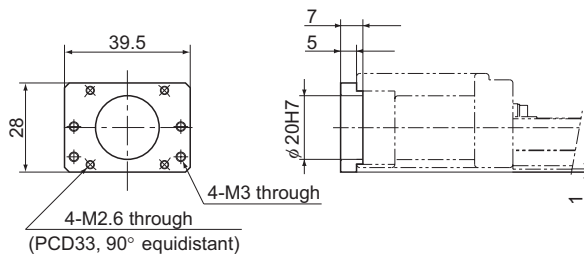

KR20

AN

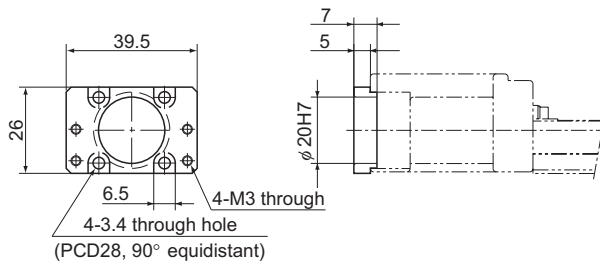

● For Model KR26

KR**	····Actuator model number
● ◇	····●: Housing A ◇: Intermediate Flange

■Housing A

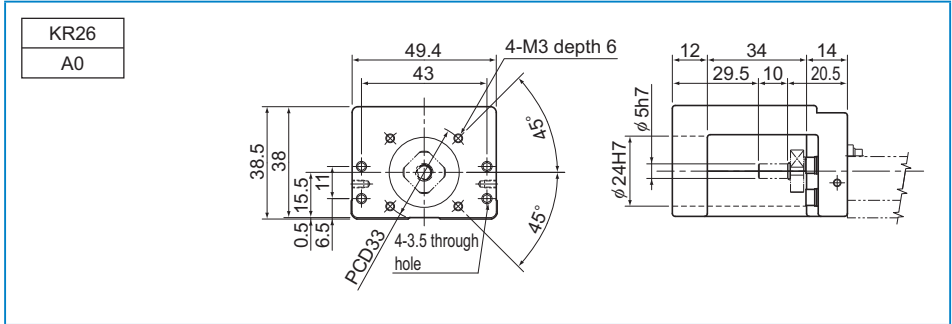

■Intermediate Flange

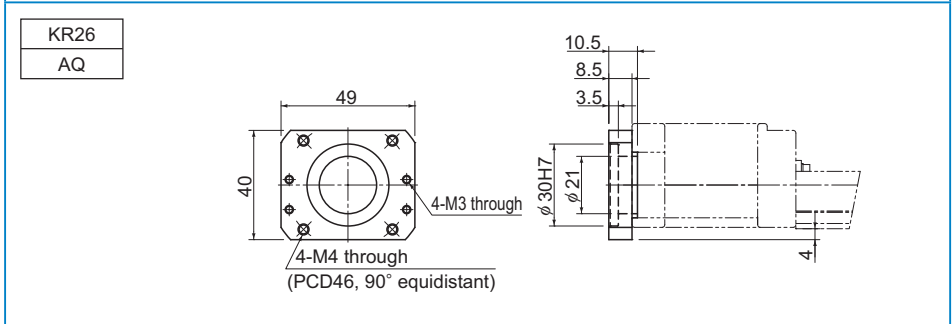
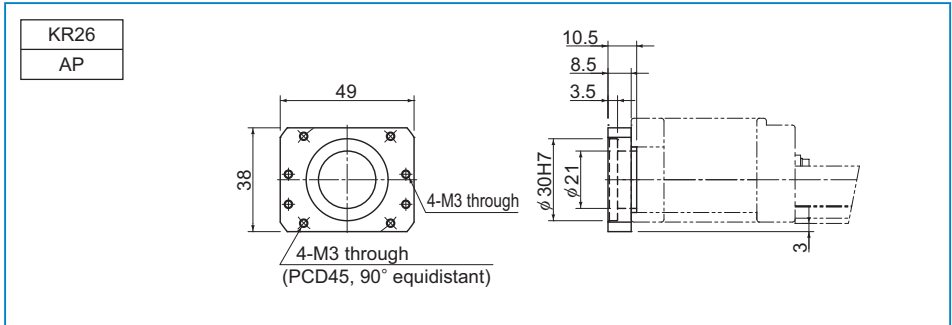

KR26

AR

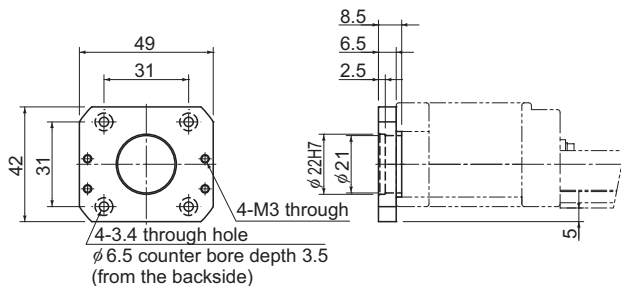

KR26

AS

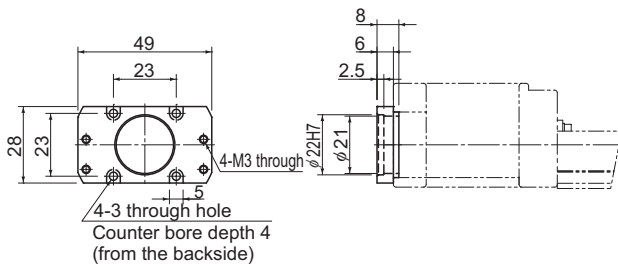

KR26

AM

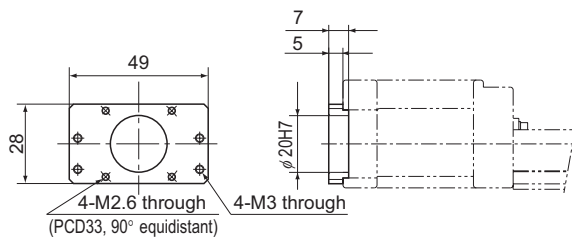

KR26

AN

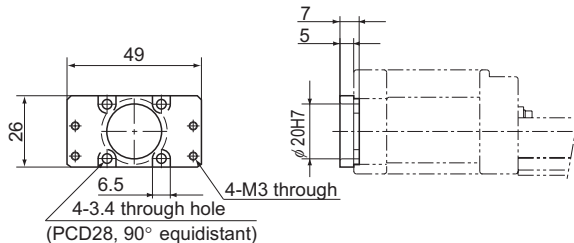

● For Model KR30H

KR**	··· Actuator model number
●	··· Housing A
◇	◇ Intermediate Flange

■ Housing A

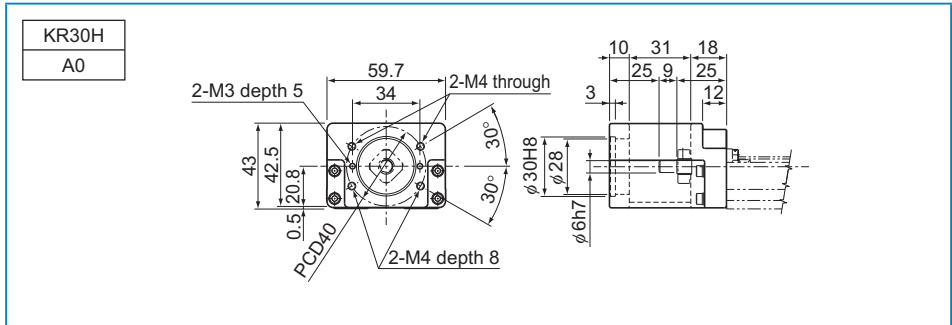

■ Intermediate Flange

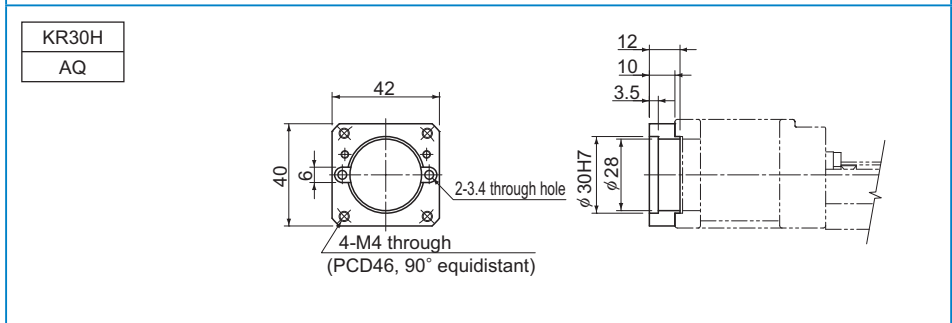
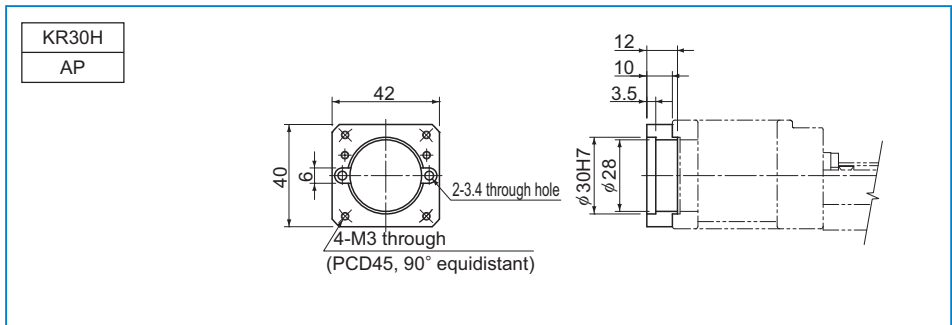

KR30H

AR

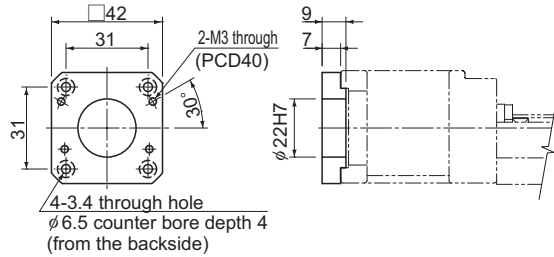

KR30H

AT

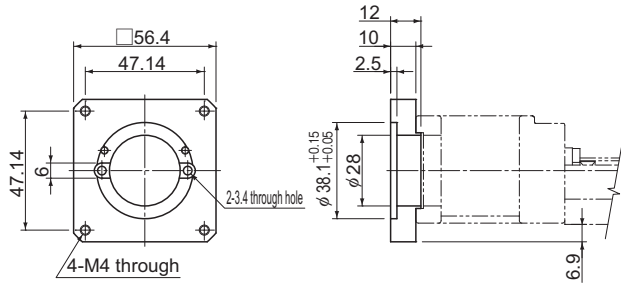

KR30H

AU

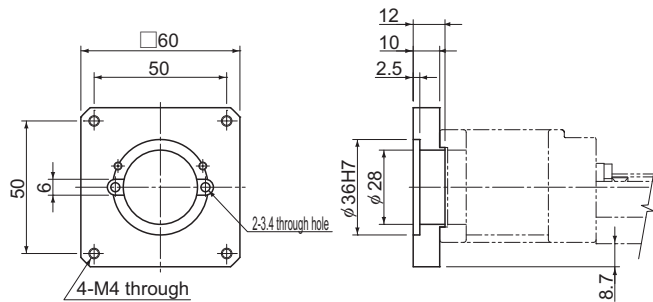

● For Model KR33

KR**	···· Actuator model number
● ◇	····●: Housing A ◇: Intermediate Flange

■ Housing A

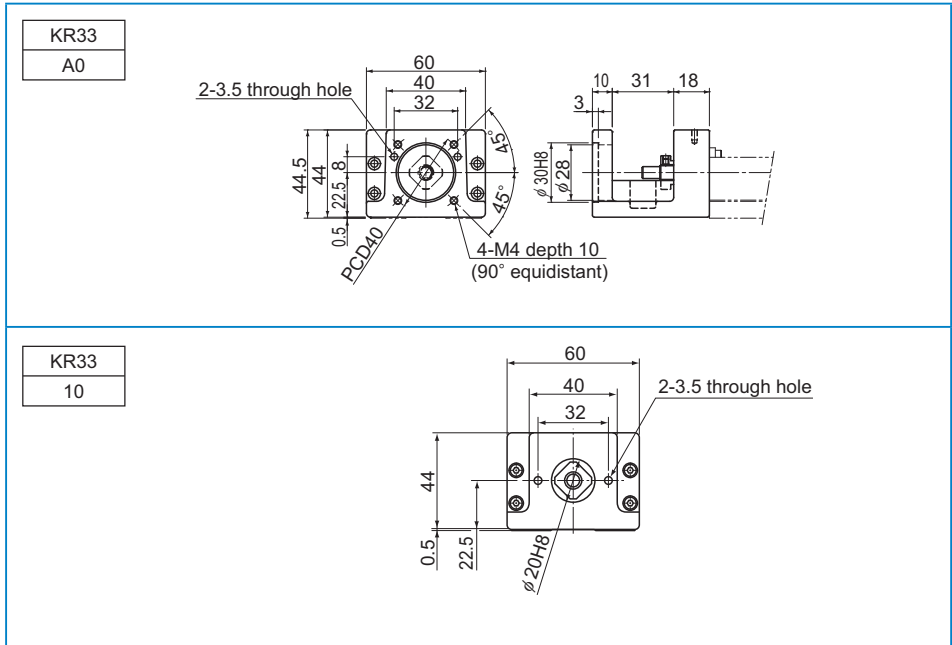

■Housing A for a Separate Motor

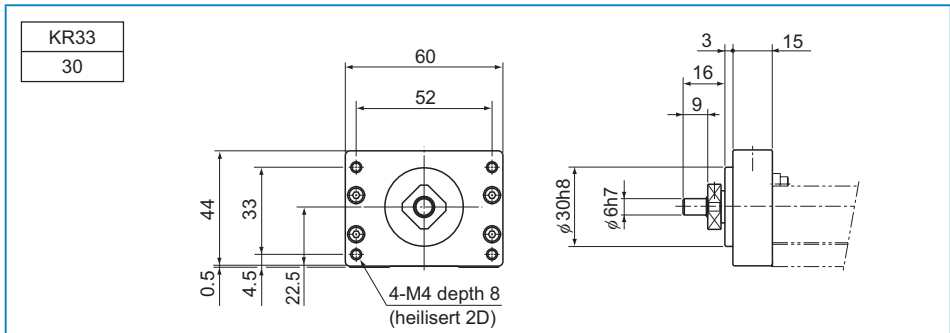

■Turnaround Housing A

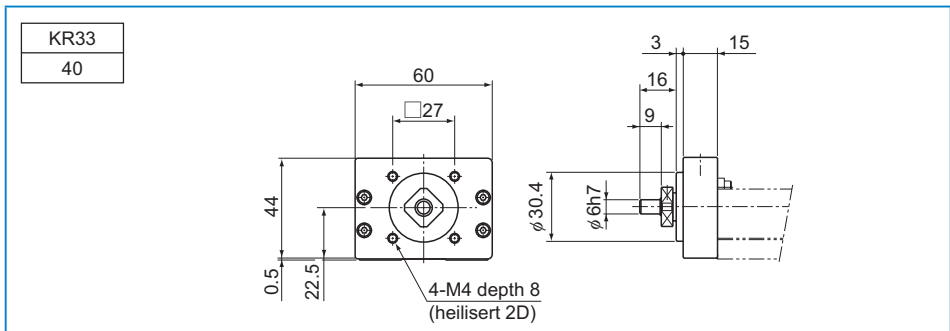

■Intermediate Flange

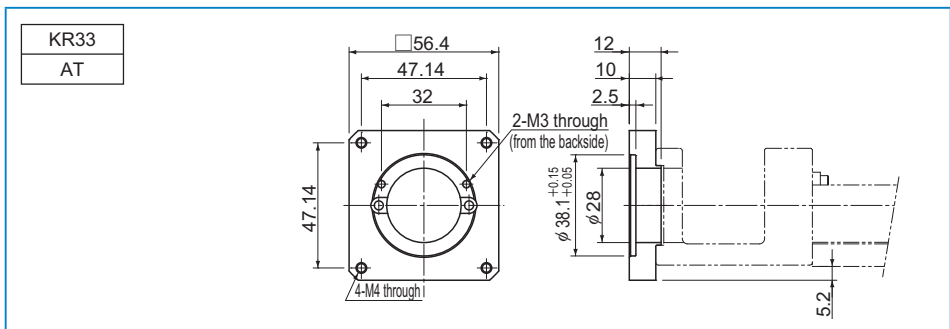

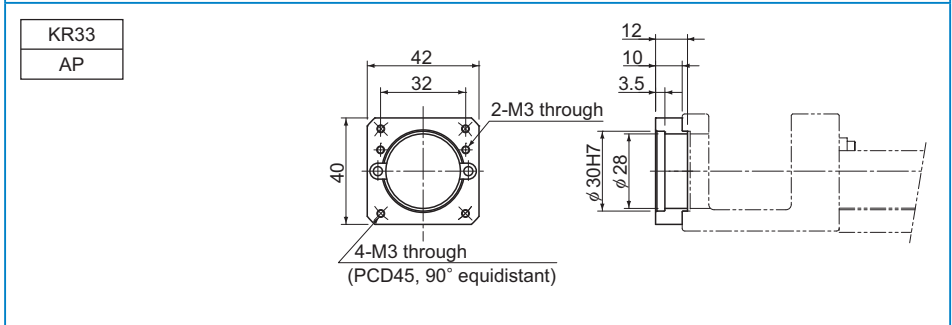
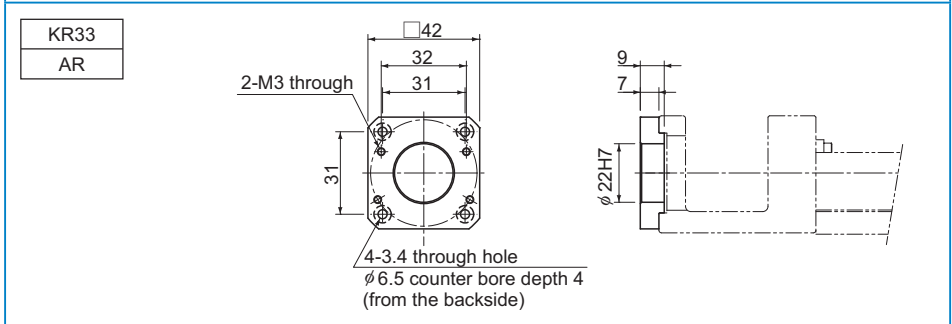
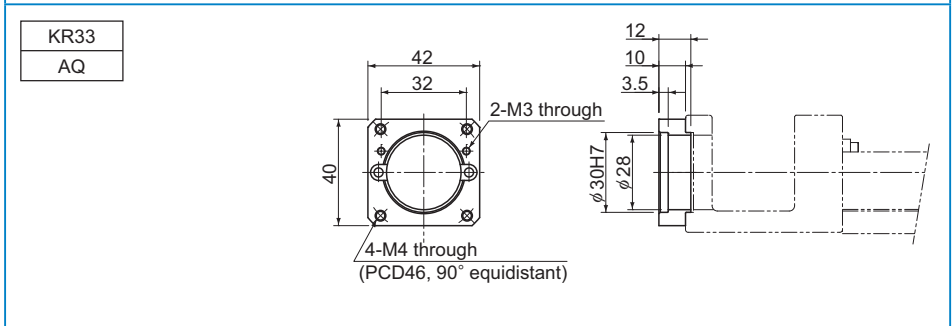
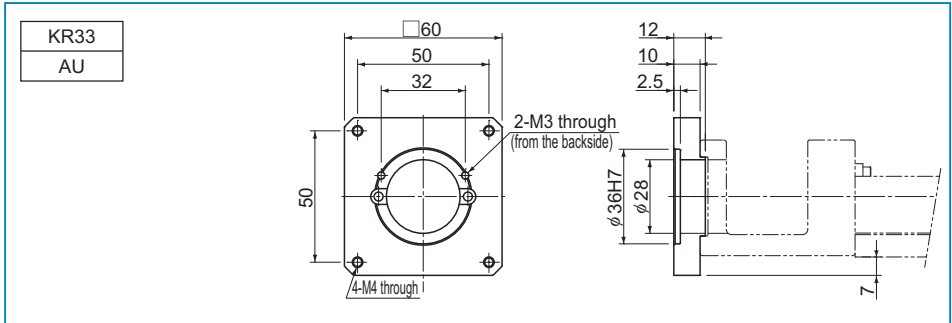

● For Model KR45H

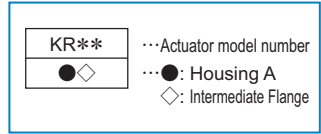

■Housing A

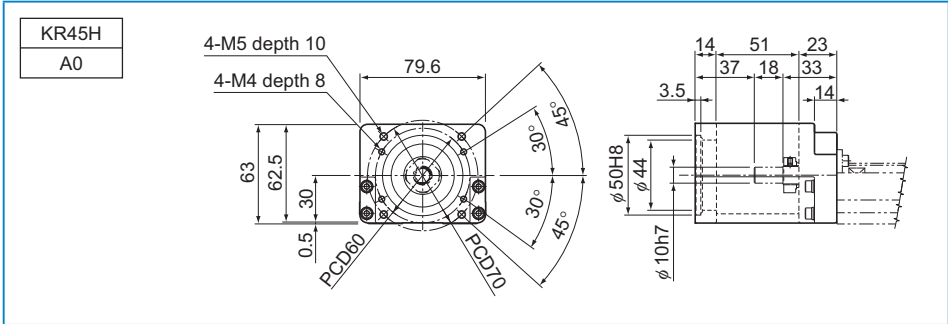

■Intermediate Flange

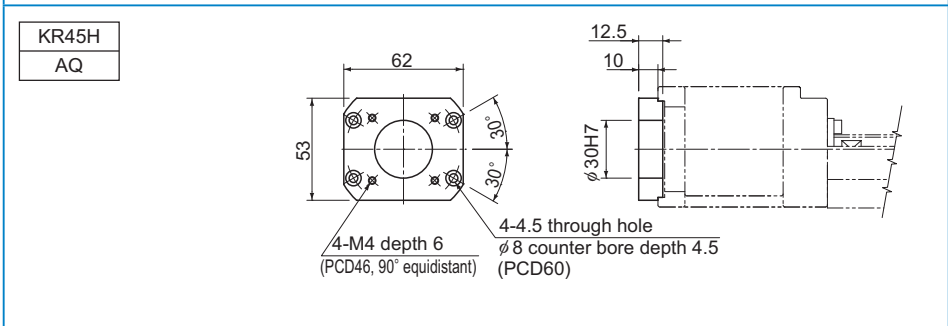
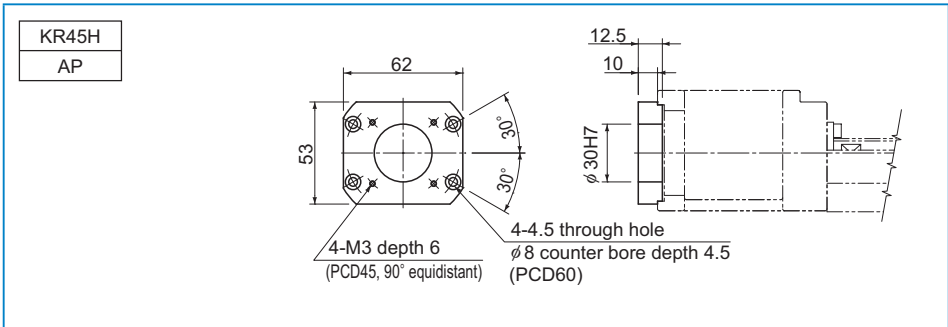

LM Guide Actuator (Options)

KR45H

AY

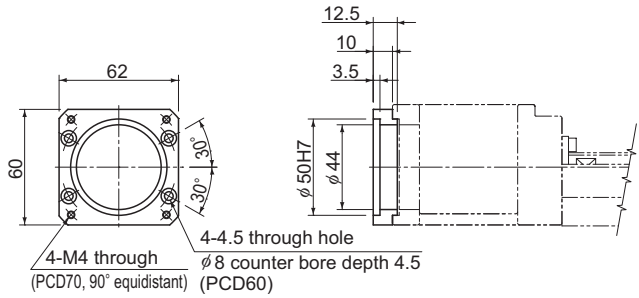

KR45H

AU

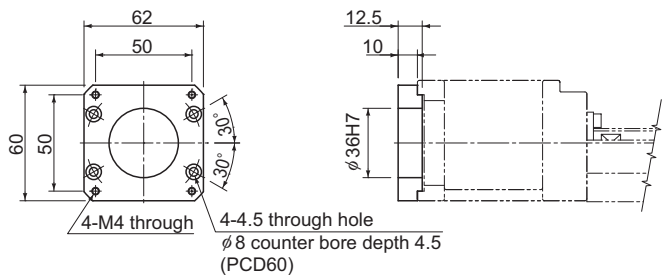

● For Model KR46

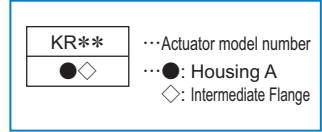

■ Housing A

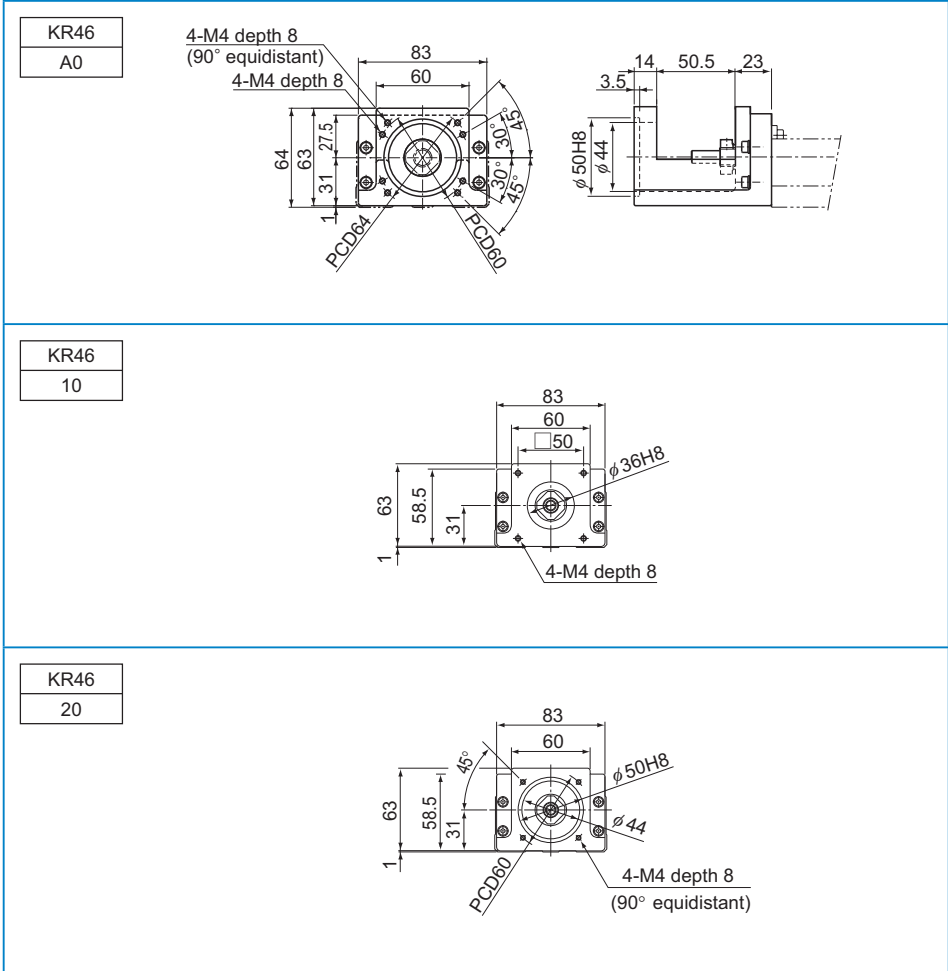

LM Guide Actuator (Options)

KR46

30

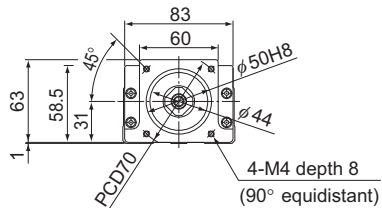

KR46

40

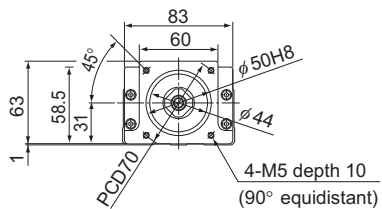

■Housing A for a Separate Motor

KR46

50

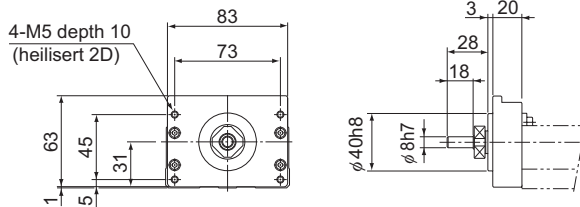

Turnaround Housing A

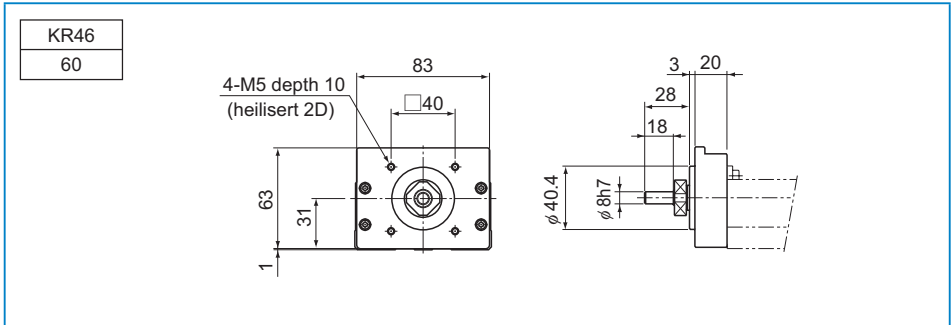

Intermediate Flange

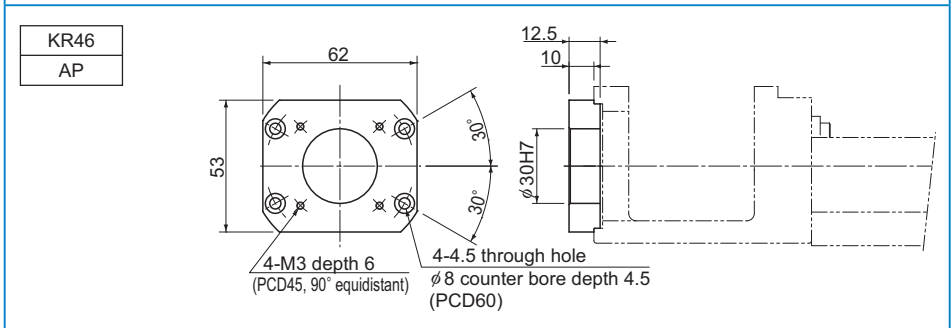
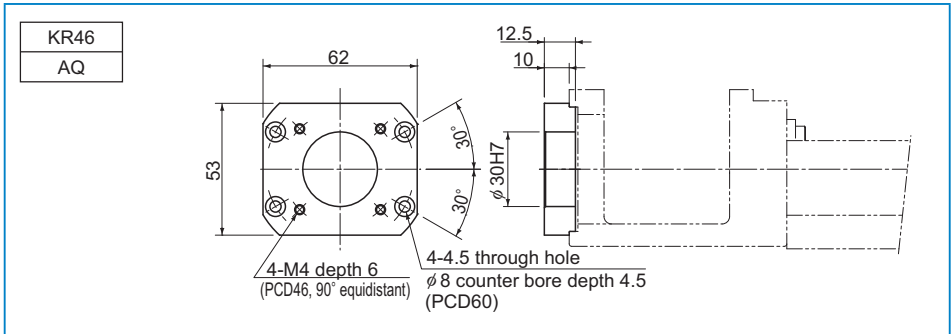

● For Model KR55

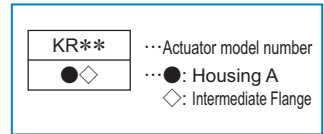

■ Housing A

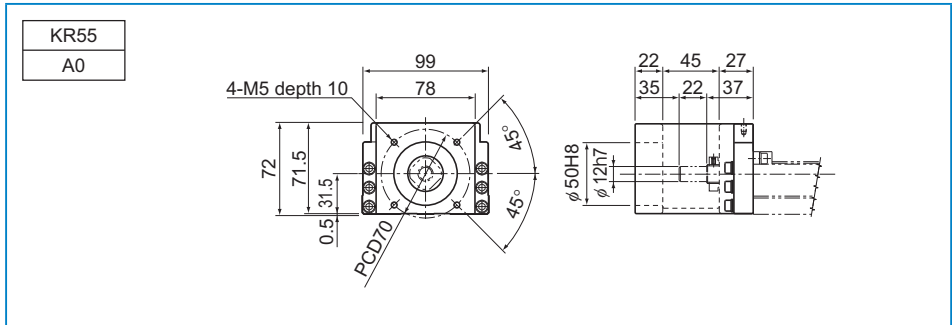

■ Turnaround Housing A

Note) Specify mounting holes when ordering.

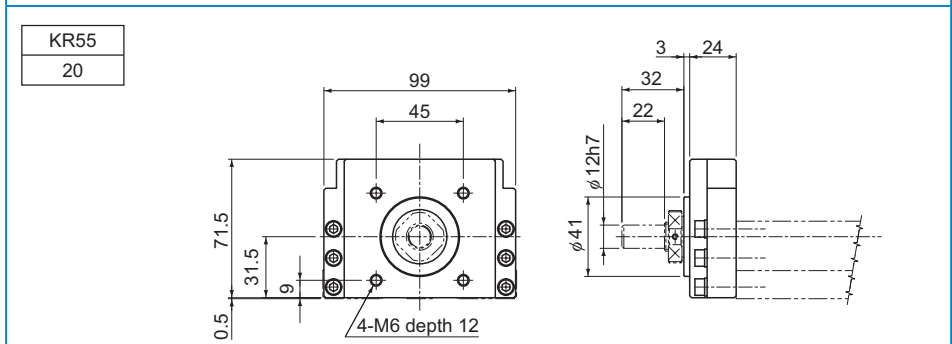
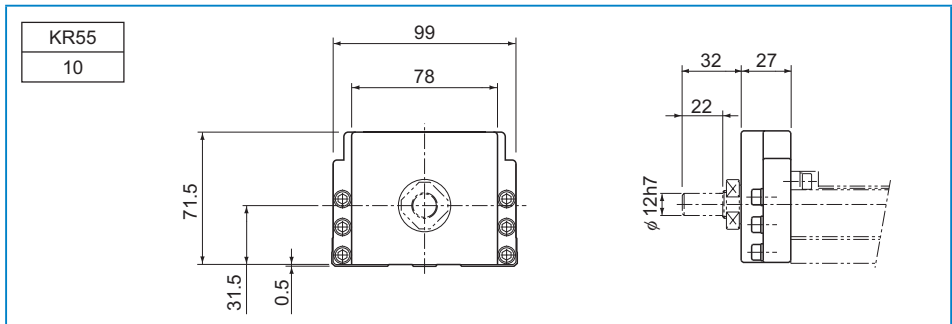

Intermediate Flange

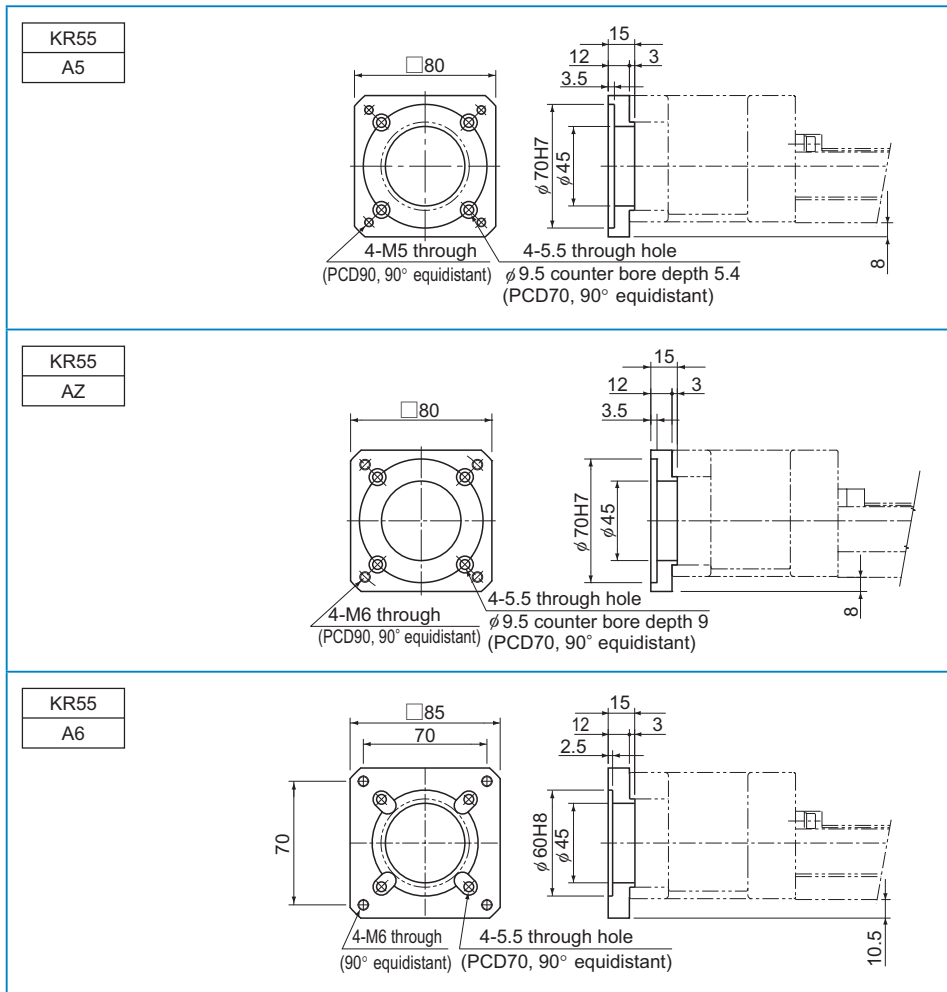

● For Model KR65

KR**	···Actuator model number
●◇	···●: Housing A ◇: Intermediate Flange

■Housing A

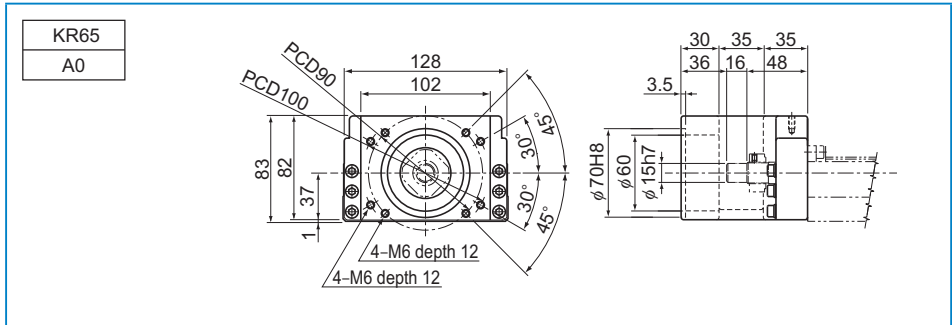

■Turnaround Housing A

Note) Specify mounting holes when ordering.

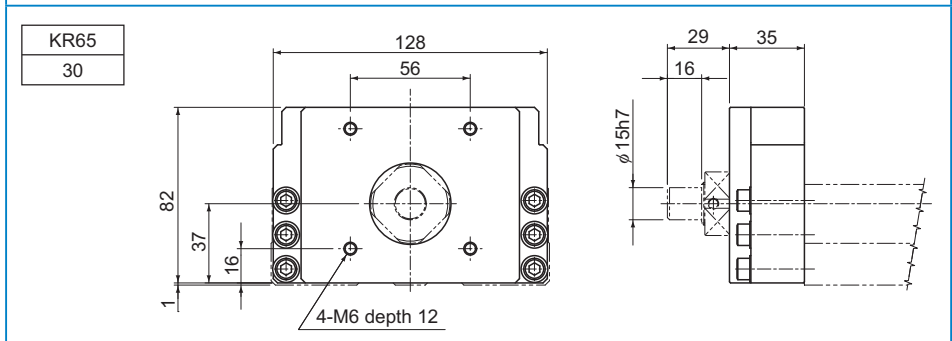
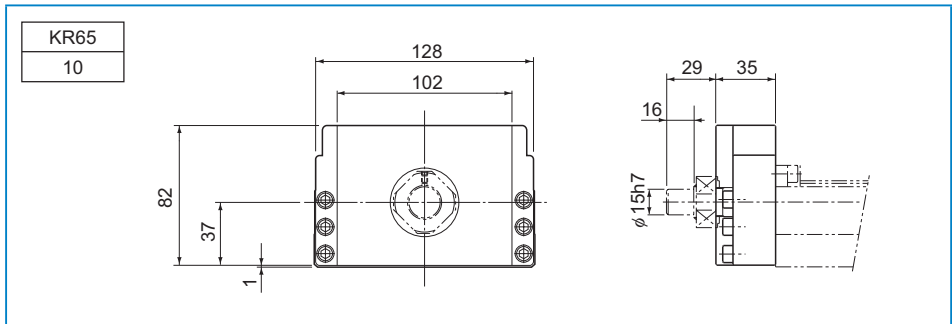

Intermediate Flange

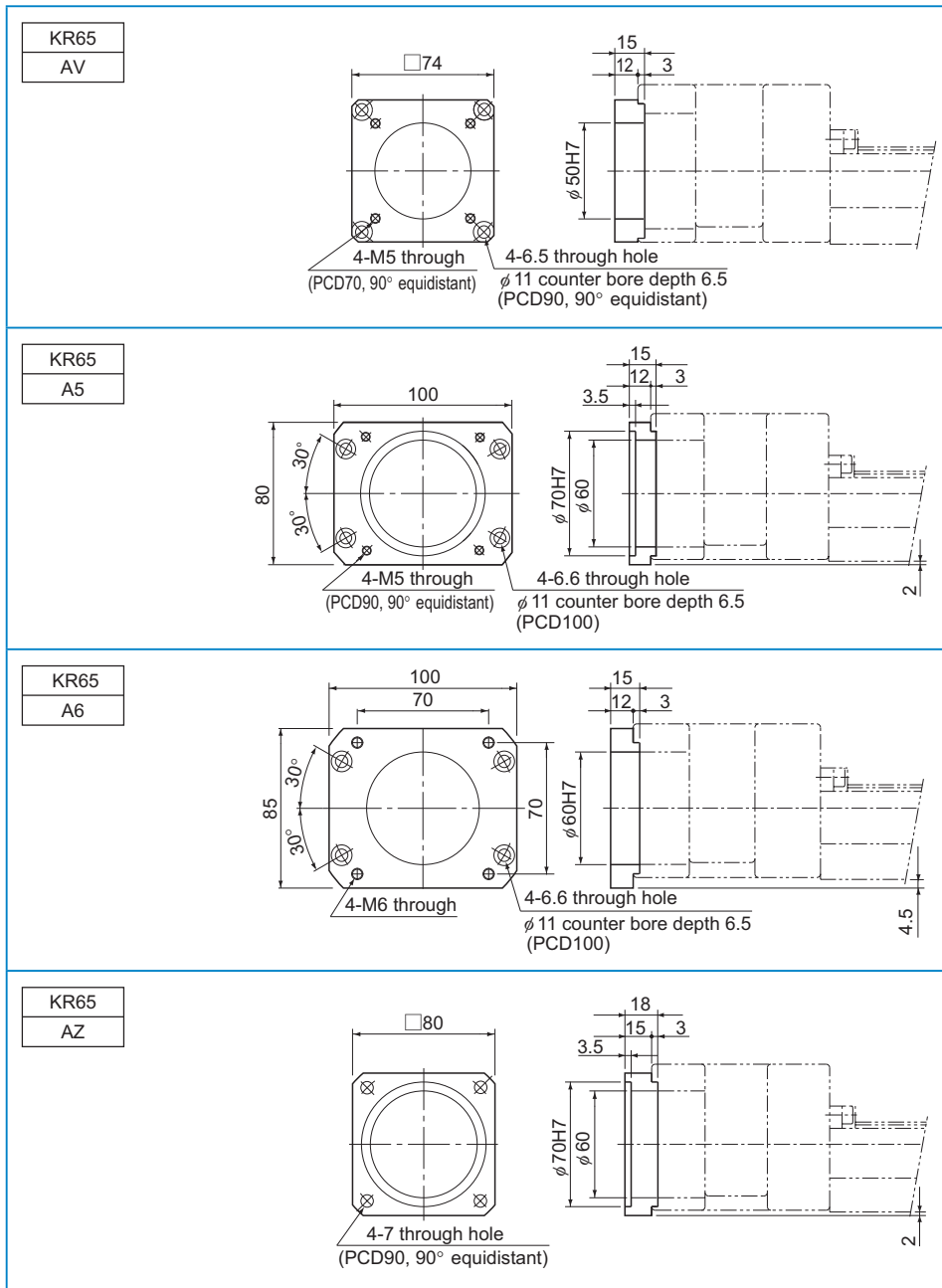

Motor Wrap Type

Model KR is available in “Motor Wrap” types that allow the motor to be turned around in order to minimize the dimension in the longitudinal direction. (Pulley ratio: 1:1).
Contact THK for details.

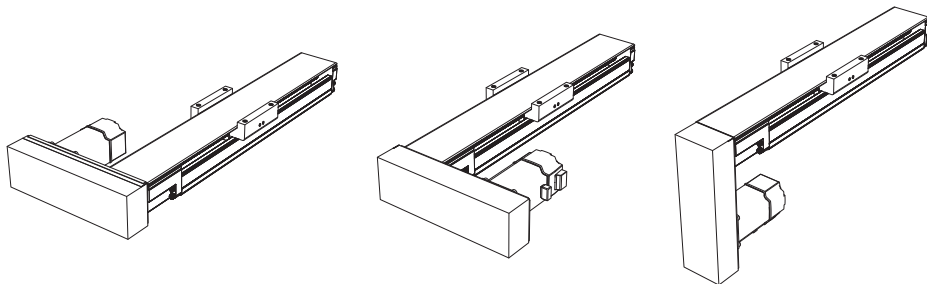

XY Bracket (for Reference)

Brackets for installing models SKR33/46 and models KR33/46 only are available. The brackets use aluminum to reduce the weights and keep the inertia as low as possible.

[KR-008XS (for Model KR33, Single-Shaft Type, and for Model SKR33, without Cover, Single-Shaft Type)]

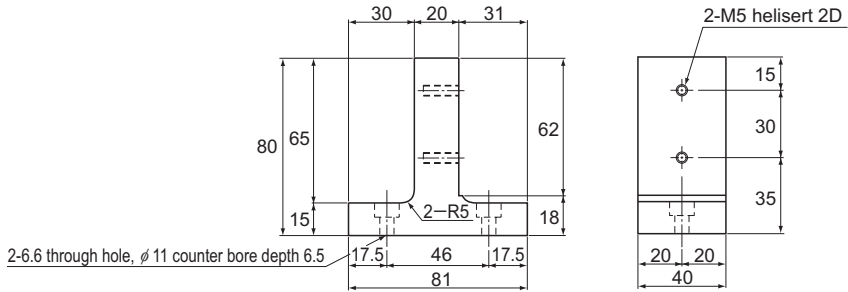

[KR-008XL (for Model KR46, Single-Shaft Type, and for Model SKR46, Single-Shaft Type)]

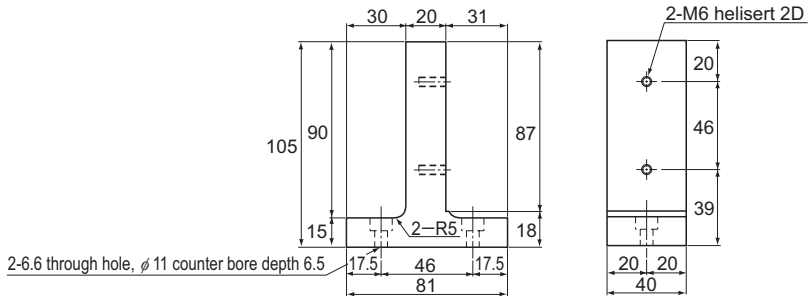

[KR-003XS (for Model KR33, Outer Rail Fixed, and for Model SKR33, without Cover, Outer Rail Fixed)]

KR46A+KR33A

SKR46A+SKR33A
Without a cover

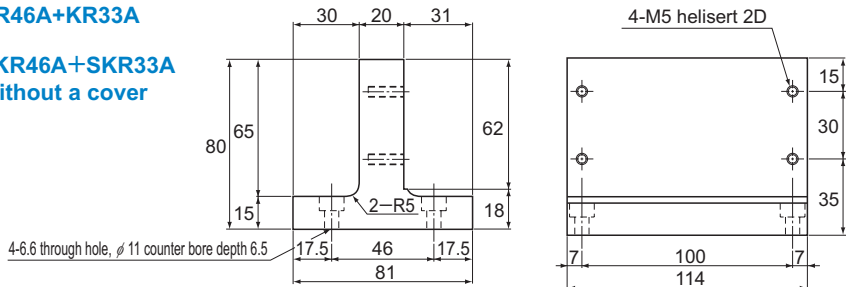

[KR-003XL (for Model KR46, Outer Rail Fixed, and for Model SKR46, Outer Rail Fixed)]

KR46A+KR46A

SKR46A+SKR46A

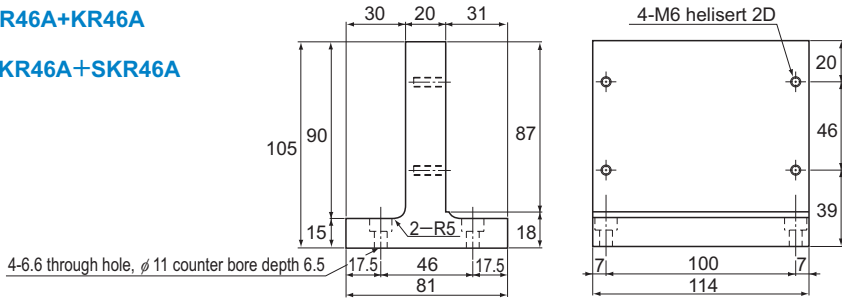

[KR-002XS (for Model KR33, Slider Fixed, and for Model SKR33, with Cover, Slider Fixed)]

KR46A+KR33A

SKR46A+SKR33A
With a cover

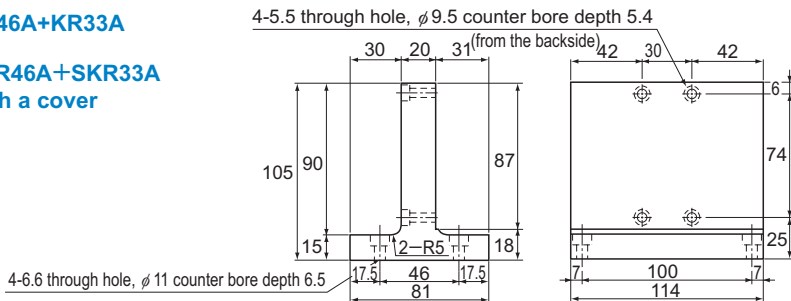

[Example of Combinations]

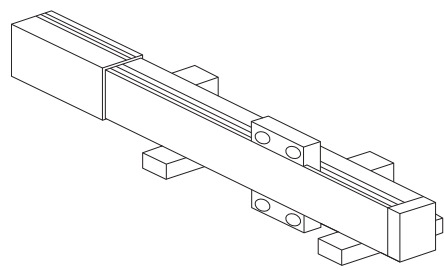

For single shaft

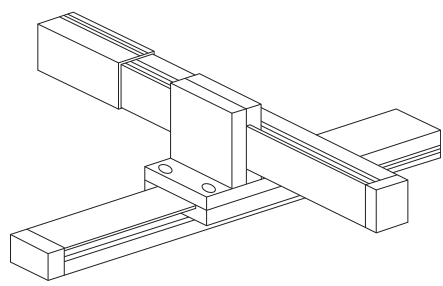

Slider fixed

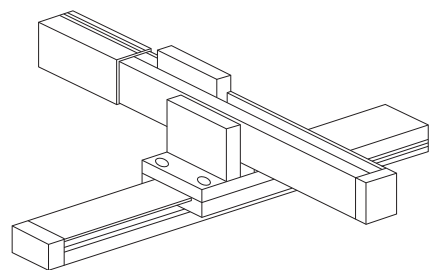

Outer rail fixed

LM Guide Actuator (Options)

Model No.

LM Guide Actuator

Model No.	Ball Screw Lead	Inner block type	Stroke	Accuracy
SKR33	10	A	0195	P

①

②

③

④

⑤

SKR20	01 : 1mm	A	0025 : 25mm	No symbol: normal grade H : High accuracy grade P : Precision Grade
SKR26	02 : 2mm	B	0050 : 50mm	
SKR33	06 : 6mm	C	∅	
SKR46	10 : 10mm	D	1490 : 1490mm	
SKR55	20 : 20mm			
SKR65	25 : 25mm			
	30 : 30mm			
KR15	40 : 40mm			
KR20	50 : 50mm			
KR26				
KR30H				
KR33				
KR45H				
KR46				
KR55				
KR65				

If "2" (with Bellows) was selected for the cover ⑦, specify a stroke incorporating the bellows (→ **A2-47**, **A2-125**).

The available ball screw leads differ depending on the model.

SKR20 : "01", "06"

SKR26 : "02", "06"

SKR33 : "06", "10", "20" (20 mm available for inner block A and B only)

SKR46 : "10", "20"

SKR55 : "20", "30", "40"

SKR65 : "20", "25", "30", "50"

KR15 : "01", "02"

KR20 : "01", "06"

KR26 : "02", "06"

KR30H : "06", "10"

KR33 : "06", "10"

KR45H : "10", "20"

KR46 : "10", "20"

KR55 : "20"

KR65 : "25"

With/without a motor	Cover	Sensor	Housing A/ Intermediate Flange																																												
0	1	B	AQ																																												
⑥	⑦	⑧	⑨																																												
<table border="1"> <tr> <td>0: direct-coupled (without a motor)</td> </tr> <tr> <td>1: direct-coupled (with a motor, specified by the customer)</td> </tr> </table>	0: direct-coupled (without a motor)	1: direct-coupled (with a motor, specified by the customer)	<table border="1"> <tr> <td>0: without a cover</td> </tr> <tr> <td>1: with a cover</td> </tr> <tr> <td>2: with a bellows</td> </tr> </table>	0: without a cover	1: with a cover	2: with a bellows	<table border="1"> <tr> <td>0: none</td> <td>10</td> </tr> <tr> <td>1</td> <td>20</td> </tr> <tr> <td>2</td> <td>30</td> </tr> <tr> <td>6</td> <td>40</td> </tr> <tr> <td>7</td> <td>50 (KR only)</td> </tr> <tr> <td>B</td> <td>60</td> </tr> <tr> <td>E</td> <td>A0</td> </tr> <tr> <td>H</td> <td>A5</td> </tr> <tr> <td>L</td> <td>A6</td> </tr> <tr> <td>J</td> <td>AM</td> </tr> <tr> <td>M</td> <td>AN</td> </tr> <tr> <td></td> <td>AP</td> </tr> <tr> <td></td> <td>AQ</td> </tr> <tr> <td></td> <td>AR</td> </tr> <tr> <td></td> <td>AS</td> </tr> <tr> <td></td> <td>AT</td> </tr> <tr> <td></td> <td>AU</td> </tr> <tr> <td></td> <td>AV</td> </tr> <tr> <td></td> <td>AY</td> </tr> <tr> <td></td> <td>AZ</td> </tr> </table>	0: none	10	1	20	2	30	6	40	7	50 (KR only)	B	60	E	A0	H	A5	L	A6	J	AM	M	AN		AP		AQ		AR		AS		AT		AU		AV		AY		AZ
0: direct-coupled (without a motor)																																															
1: direct-coupled (with a motor, specified by the customer)																																															
0: without a cover																																															
1: with a cover																																															
2: with a bellows																																															
0: none	10																																														
1	20																																														
2	30																																														
6	40																																														
7	50 (KR only)																																														
B	60																																														
E	A0																																														
H	A5																																														
L	A6																																														
J	AM																																														
M	AN																																														
	AP																																														
	AQ																																														
	AR																																														
	AS																																														
	AT																																														
	AU																																														
	AV																																														
	AY																																														
	AZ																																														
<p>If "0" is selected, a coupling is not attached. If a coupling is required, please indicate so.</p> <p>"1" means that a motor specified by the customer is mounted. For item ⑨, select a housing A/intermediate flange that matches the specified motor.</p>																																															
<p>Several motors by different manufacturers can be mounted. Contact THK for details.</p>																																															

A type with a wrap-around housing A and a motor wrap-around type, which are not contained in the catalog, are also available. Contact THK for details.

[Handling]

- (1) Do not disassemble the parts. This will result in loss of functionality.
- (2) Take care not to drop or strike the parts. Doing so may cause injury or damage. Giving an impact to it could also cause damage to its function even if the product looks intact.
- (3) When handling the product, wear protective gloves, safety shoes, etc., as necessary to ensure safety.

[Precautions on Use]

- (1) Prevent foreign material, such as cutting chips or coolant, from entering the product. Failure to do so may cause damage.
- (2) If the product is used in an environment where cutting chips, coolant, corrosive solvents, water, etc., may enter the product, use bellows, covers, etc., to prevent them from entering the product.
- (3) If foreign material such as cutting chips adheres to the product, replenish the lubricant after cleaning the product.
- (4) The service temperature range of this product is 0 to 40°C (no freezing or condensation). If you consider using this product outside the service temperature range, contact THK.
- (5) Exceeding the dangerous speed may lead the components to be damaged or cause an accident. Be sure to use the product within the specification range designated by THK.
- (6) Micro-strokes tend to obstruct oil film to form on the raceway in contact with the rolling element, and may lead to fretting corrosion. Take consideration using grease offering excellent fretting prevention. It is also recommended that a stroke movement corresponding to the length of the nut block be made on a regular basis to make sure oil film is formed between the raceway and rolling element.
- (7) Do not use undue force when fitting parts (pin, key, etc.) to the product. This may generate permanent deformation on the raceway, leading to loss of functionality.
- (8) If the product is operating or in the ready state, never touch a moving part. In addition, do not enter the operating area of the actuator.
- (9) If two or more people are involved in the operation, confirm the procedures such as a sequence, signs and anomalies in advance, and appoint another person for monitoring the operation.
- (10) Insufficient rigidity or accuracy of mounting members causes the bearing load to concentrate on one point and the bearing performance will drop significantly. Accordingly, give sufficient consideration to the rigidity/accuracy of the housing and base and strength of the fixing bolts.

[Lubrication]

- (1) Thoroughly wipe off the anti-rust oil before using the product.
- (2) Lubrication is needed to let the models KR/SKR demonstrate their functions fully. Using the product without sufficient lubrication may increase wear of the rolling elements or shorten the service life. Note the standard grease used in the product as follows.

Model KR15	THK AFF Grease
Models SKR20, SKR26, KR20, KR26	THK AFA Grease
Models SKR33, SKR46, SKR55, SKR65, KR30H, KR33, KR45H, KR46, KR55, KR65	THK AFB-LF Grease

- (3) Do not mix different lubricants. Mixing greases using the same type of thickening agent may still cause adverse interaction between the two greases if they use different additives, etc.
- (4) When using the product in locations exposed to constant vibrations or in special environments such as clean rooms, vacuum and low/high temperature, use the grease appropriate for the specification/environment.
- (5) When adopting oil lubrication method, contact THK.
- (6) Because the intervals between greasing vary depending on the conditions of product use, it is recommended that the greasing interval be determined through an initial inspection. Although the lubrication interval may vary according to use conditions and the service environment, lubrication should be performed approximately every 100 km in travel distance (three to six months). Set the final lubrication interval/amount based on the actual machine.
- (7) The consistency of grease changes according to the temperature. Take note that the slide resistance of the models KR/SKR also changes as the consistency of grease changes.
- (8) After lubrication, the slide resistance of the models KR/SKR may increase due to the agitation resistance of grease. Be sure to perform a break-in to let the grease spread fully, before operating the machine.
- (9) Excess grease may scatter immediately after lubrication, so wipe off scattered grease as necessary.
- (10) The properties of grease deteriorate and its lubrication performance drops over time, so grease must be checked and added properly according to the use frequency of the machine.

[Storage]

When storing the models KR/SKR, enclose them in a package designated by THK and store them in a room in a horizontal orientation while avoiding high temperature, low temperature and high humidity.

After the product has been in storage for an extended period of time, lubricant inside may have deteriorated, so add new lubricant before use.

[Disposal]

Dispose of the product properly as industrial waste.

[Instruction Manual]

You can download the “LM Guide Actuator Models KR/SKR -- Instruction Manual” from the THK technical support website.

Technical support website: <https://tech.thk.com/>



LM Guide Actuator

THK General Catalog

LM Guide Actuator

THK General Catalog

B Support Book

Features	B 2-4
Features of the LM Guide Actuator.....	B 2-4
• Structure and Features	B 2-4
• Caged Ball Technology (SKR).....	B 2-6
Point of Selection	B 2-7
Static Safety Factor	B 2-7
Service Life.....	B 2-8
Example of Calculating the Nominal Life ..	B 2-11
Options	B 2-20
Cover	B 2-21
Bellows	B 2-21
Sensor	B 2-22
Housing	B 2-22
Motor Wrap Type	B 2-23
XY Bracket (for Reference)	B 2-23
Model No.	B 2-24
Precautions on Use	B 2-26

A Product Descriptions (Separate)

Caged Ball LM Guide Actuator Model SKR ..	A2-4
• Structure and Features	A2-4
• Caged Ball Technology	A2-6
• Types and Features	A2-9
• Load Ratings in All Directions and Static Permissible Moment ..	A2-10
• Maximum Speeds with Different Strokes ..	A2-16
• Lubrication	A2-18
• Static Safety Factor	A2-19
• Service Life	A2-20
• Accuracy Standards	A2-23
• Model Number Coding	A2-28

Dimensional Drawing, Dimensional Table

Model SKR20 Standard Type	A2-30
Model SKR20 (with a Cover)	A2-31
Model SKR26 Standard Type	A2-32
Model SKR26 (with a Cover)	A2-33
Model SKR33 Standard Type	A2-34
Model SKR33 (with a Cover)	A2-35
Model SKR33 Standard Type	A2-36
Model SKR33 (with a Cover)	A2-37
Model SKR46 Standard Type	A2-38
Model SKR46 (with a Cover)	A2-39
Model SKR46 Standard Type	A2-40
Model SKR46 (with a Cover)	A2-41
Model SKR55 Standard Type	A2-42
Model SKR55 (with a Cover)	A2-43
Model SKR65 Standard Type	A2-44
Model SKR65 (with a Cover)	A2-45
• Mass of Moving Element	A2-46

Options	A2-47
Bellows	A2-47
Sensor	A2-52
Housing	A2-56
Intermediate Flange	A2-57
Motor Wrap Type	A2-72

LM Guide Actuator Model KR	A2-74
• Structure and Features	A2-74
• Types and Features	A2-78
• Load Ratings in All Directions and Static Permissible Moment ..	A2-79
• Maximum Speeds with Different Strokes ..	A2-84
• Lubrication	A2-86
• Static Safety Factor	A2-87
• Service Life	A2-88
• Accuracy Standards	A2-91
• Model Number Coding	A2-96

Dimensional Drawing, Dimensional Table

Model KR15 Standard Type	A2-98
Model KR15 (with a Cover)	A2-99
Model KR20 Standard Type	A2-100
Model KR20 (with a Cover)	A2-101
Model KR26 Standard Type	A2-102
Model KR26 (with a Cover)	A2-103
Model KR30H Standard Type	A2-104
Model KR30H (with a Cover)	A2-105
Model KR30H Standard Type	A2-106
Model KR30H (with a Cover)	A2-107
Model KR33 Standard Type	A2-108
Model KR33 (with a Cover)	A2-109
Model KR33 Standard Type	A2-110
Model KR33 (with a Cover)	A2-111
Model KR45H Standard Type	A2-112
Model KR45H (with a Cover)	A2-113
Model KR45H Standard Type	A2-114
Model KR45H (with a Cover)	A2-115
Model KR46 Standard Type	A2-116
Model KR46 (with a Cover)	A2-117
Model KR46 Standard Type	A2-118
Model KR46 (with a Cover)	A2-119
Model KR55 Standard Type	A2-120
Model KR55 (with a Cover)	A2-121
Model KR65 Standard Type	A2-122
Model KR65 (with a Cover)	A2-123
• Mass of Moving Element	A2-124

Options	A2-125
Bellows	A2-125
Sensor	A2-131
Housing	A2-135
Intermediate Flange	A2-136
Motor Wrap Type	A2-160
XY Bracket (for Reference)	A2-161

Model No.	A2-164
-----------------------	---------------

Precautions on Use	A2-166
---------------------------------	---------------

Features of the LM Guide Actuator

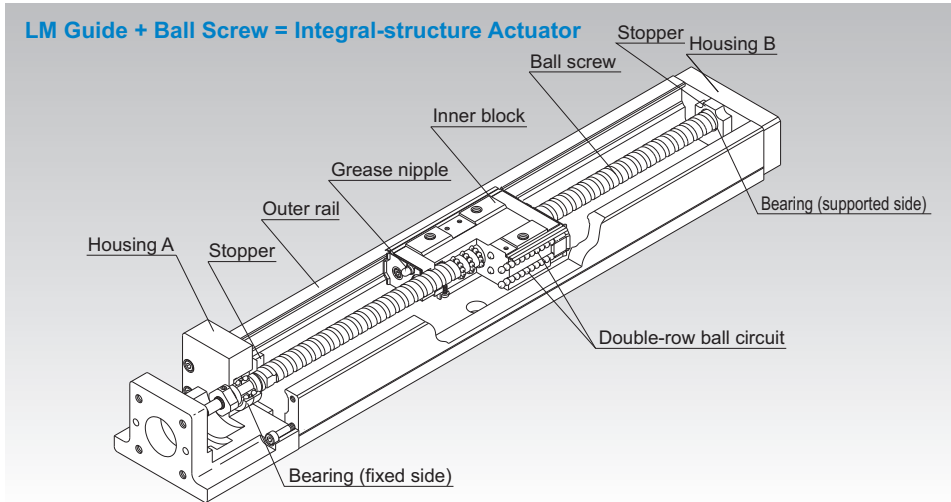

Fig.1 Structure of LM Guide Actuator Model KR

Structure and Features

Because of its integral-structure inner block consisting of a highly rigid outer rail with a U-shaped cross section, LM Guide units on both side faces and a Ball Screw unit in the center, the LM Guide Actuator model SKR/KR achieves a highly rigid and highly accurate actuator in a minimal space. In addition, since the housings A and B also serve as support units and the inner block as a table, this model allows significant reduction of man-hours required for design and assembly, thus contributing to total cost cutting.

By using ball cages in the LM Guide unit and the Ball Screw unit, model SKR achieves higher speed operation, lower noise, longer-term maintenance-free operation, etc. than the previous model KR (a ball cage is used only for the LM Guide unit of models SKR20 and SKR26 and their Ball Screw units are fitted with QZ Lubricator).

Features

Features of the LM Guide Actuator

[4-way Equal Load]

Each row of balls is arranged at a contact angle of 45° so that the rated load on the inner block is uniform under loads applied to the inner block in the four directions (radial, reverse radial and lateral directions). As a result, model KR can be used in any mounting orientation.

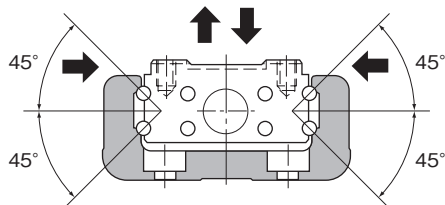

Fig.2 Load Capacity and Contact Angle of Model SKR/KR

[High Accuracy]

Since the linear guide section consists of 4 rows of circular-arc grooves that enable balls to smoothly move even under a preload, a highly rigid guide with no clearance is achieved. Additionally, variation in frictional resistance caused by load fluctuation is minimized, allowing the system to follow highly accurate feed.

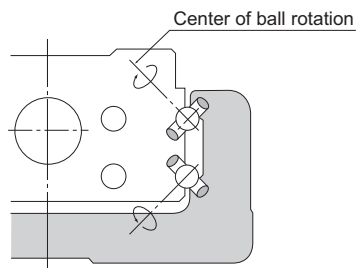

Fig.3 Contact Structure of Model SKR/KR

[High Rigidity]

Use of an outer rail with a U-shaped cross section increases the rigidity against a moment and torsion.

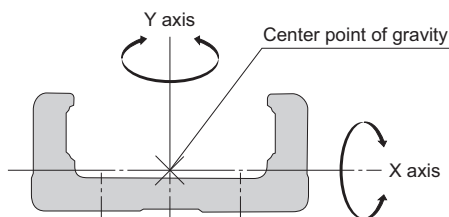

Fig.4 Cross Section of the Outer Rail

Table1 Cross-sectional Characteristics of the Outer rail Rail

Model No.	$I_x[\text{mm}^4]$	$I_y[\text{mm}^4]$	Mass[kg/m]
SKR20	6.0×10^3	6.14×10^4	2.6
SKR26	1.66×10^4	1.48×10^5	3.9
SKR33	5.35×10^4	3.52×10^5	6.1
SKR46	2.05×10^5	1.45×10^6	12.6
SKR55	2.07×10^5	2.09×10^6	13.2
SKR65	4.51×10^5	5.73×10^6	22.1
KR15	9.08×10^2	1.42×10^4	1.04
KR20	6.1×10^3	6.2×10^4	2.6
KR26	1.7×10^4	1.5×10^5	3.9
KR30H	2.7×10^4	2.8×10^5	5.0
KR33	6.2×10^4	3.8×10^5	6.6
KR45H	8.4×10^4	8.9×10^5	9.0
KR46	2.4×10^5	1.5×10^6	12.6
KR55	2.2×10^5	2.3×10^6	15.0
KR65	4.6×10^5	5.9×10^6	23.1

I_x =geometrical moment of inertia around X axis

I_y =geometrical moment of inertia around Y axis

Caged Ball Technology (SKR)

[High Lubricity]

Model SKR uses ball cages to eliminate friction between balls and significantly improve torque characteristics. As a result, the torque fluctuation is reduced and superb lubricity is achieved.

Item	Description
Shaft diameter/lead	$\phi 13/10\text{mm}$
Shaft rotation speed	60min^{-1}

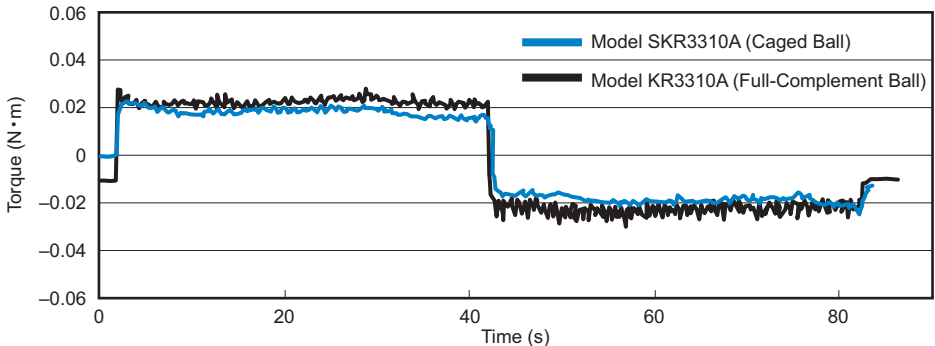

Fig.5 Comparison of Torque Fluctuation between Model SKR and Model KR

[Low Noise, Acceptable Running Sound]

In model SKR, the use of a ball cage in the LM Guide section and Ball Screw section (excluding models SKR20/26) has eliminated collision noise between the balls. As a result, low noise and acceptable running sound are achieved.

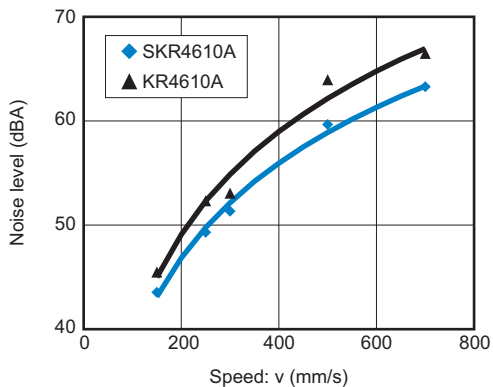

Fig.6 Comparison of Noise between Model SKR4610A and Model KR4610A

Static Safety Factor

[Calculating the Static Safety Factor]

● LM Guide Unit

To calculate a load applied to the LM Guide of model SKR/KR, the average load required for calculating the service life and the maximum load needed for calculating the static safety factor must be obtained first. In particular, if the system starts and stops frequently, or if a large moment caused by an overhung load is applied to the system, it may receive an unexpectedly large load.

When selecting a model number, make sure that the desired model is capable of receiving the required maximum load (whether stationary or in motion).

$$f_s = \frac{C_0}{P_{\max}}$$

f_s : Static safety factor

C_0 : Basic static load rating (N)

P_{\max} : Maximum applied load (N)

*The basic static load rating is a static load with a constant direction and magnitude whereby the sum of the permanent deformation of the rolling element and that of the raceway on the contact area under the maximum stress is 0.0001 times the rolling element diameter.

● Ball Screw Unit/Bearing Unit(Fixed Side)

If an unexpected external force is applied in the axial direction as a result of an inertia caused by an impact or start and stop while model SKR/KR is stationary or operating, it is necessary to take into account the static safety factor.

$$f_s = \frac{C_{0a}}{F_{\max}}$$

f_s : Static safety factor

C_{0a} : Basic static load rating (N)

F_{\max} : Maximum applied load (N)

[Standard Values for the Static Safety Factor (f_s)]

Machine type	Load conditions	Minimum Static Safety Factor (f_s)
General industrial machinery	Without vibration or impact	1.0 to 3.5
	With vibration or impact	2.0 to 5.0

*The standard value of the static safety factor may vary depending on the load conditions as well as environment, lubrication status, mounting accuracy, and/or rigidity.

Service Life

Model SKR/KR consists of an LM Guide, a Ball Screw and a support bearing. The nominal life of each component can be obtained using the basic dynamic load rating indicated in **A2-12**Table4 and **A2-80**Table3 (Rated Load of Model KR).

[LM Guide Unit]

● Nominal Life

$$L = \left(\frac{f_c \cdot C}{f_w \cdot P_c} \right)^3 \times 50$$

- L : Nominal life (km)
 (The total travel distance that 90% of a group of identical LM Guide units independently operating under the same conditions can achieve without showing flaking)
- C : Basic dynamic load rating (N)
- P_c : Calculated applied load (N)
- f_w : Load factor (see Table2 on **B2-10**)
- f_c : Contact factor (see Table1 on **B2-10**)

- If a moment is applied to model SKR-B/D or KR-B/D using two inner blocks in close contact with each other, calculate the equivalent load by multiplying the applied moment by the equivalent factor indicated in **A2-22**Table10 and **A2-90**Table9.

$$P_m = K \cdot M$$

- P_m : Equivalent load (per inner block) (N)
- K : Equivalent moment factor
 (see **A2-22**Table10 and **A2-90**Table9)
- M : Applied moment (N-mm)
 (If planning to use with a wide inner block span, contact THK.)
- If moment M_c is applied to model SKR-B/D or KR-B/D

$$P_m = \frac{K_c \cdot M_c}{2}$$

- If a radial load (P) and a moment are simultaneously applied to model SKR/KR

$$P_E = P_m + P$$

- P_E : Total equivalent radial load (N)
 Perform a nominal life calculation using the above data.

● Service Life Time

When the nominal life (L) has been obtained, the service life time is obtained using the following equation (if the stroke length and the number of reciprocations per minute are constant).

$$L_h = \frac{L \times 10^6}{2 \cdot \ell_s \cdot n_1 \times 60}$$

L_h : Service life time (h)

ℓ_s : Stroke length (mm)

n_1 : Number of reciprocations per minute (min^{-1})

[Ball Screw Unit/Bearing Unit(Fixed Side)]

● Nominal Life

$$L = \left(\frac{C_a}{f_w \cdot F_a} \right)^3 \times 10^6$$

L : Nominal life (rev)

(The total number of revolutions that 90% of a group of identical Ball Screw units independently operating under the same conditions can achieve without showing flaking)

C_a : Basic dynamic load rating (N)

F_a : Applied load (N)

f_w : Load factor (see Table2 on **B2-10**)

● Service Life Time

When the nominal life (L) has been obtained, the service life time is obtained using the following equation (if the stroke length and the number of reciprocations per minute are constant).

$$L_h = \frac{L \cdot \ell}{2 \cdot \ell_s \cdot n_1 \times 60}$$

L_h : Service life time (h)

ℓ_s : Stroke length (mm)

n_1 : Number of reciprocations per minute (min^{-1})

ℓ : Ball Screw lead (mm)

■ f_c : Contact Factor

If two inner blocks are used in close contact with each other with models SKR-B/D and KR-B/D, multiply the basic load rating by the corresponding contact factor indicated in Table1.

Table1 Contact Factor (f_c)

Inner block types	Contact factor f_c
Model SKR, KR-B Model SKR, KR-D	0.81

■ f_w : Load Factor

Table2 shows load factors.

Table2 Load Factor (f_w)

Vibrations/impact	Speed(V)	f_w
Faint	Very low $V \leq 0.25\text{m/s}$	1 to 1.2
Weak	Slow $0.25 < V \leq 1\text{m/s}$	1.2 to 1.5
Medium	Medium $1 < V \leq 2\text{m/s}$	1.5 to 2
Strong	High $V > 2\text{m/s}$	2 to 3.5

■ K : Moment Equivalent Factor (LM Guide Unit)

When the product travels under a moment, the distribution of load applied to the LM Guide is locally large (see **A1-40**). In such cases, calculate the load by multiplying the moment value by the corresponding moment equivalent factor indicated in **A2-22**Table10 and **A2-90**Table9.

Symbols K_a , K_b and K_c indicate the moment equivalent loads in the M_a , M_b and M_c directions, respectively.

Example of Calculating the Nominal Life

[Condition (Horizontal Installation)]

Assumed model number	: KR 5520A
LM Guide unit	($C = 38100\text{N}$, $C_0 = 61900\text{N}$)
Ball Screw unit	($C_a = 3620\text{N}$, $C_{0a} = 9290\text{N}$)
Bearing unit(Fixed Side)	($C_a = 7600\text{N}$, $P_{0a} = 3990\text{N}$)
Mass	: $m = 30\text{kg}$
Speed	: $v = 500\text{mm/s}$
Acceleration	: $\alpha = 2.4\text{m/s}^2$
Stroke	: $l_s = 1200\text{mm}$
Gravitational acceleration	: $g = 9.807\text{m/s}^2$
Velocity diagram	: see Fig.1

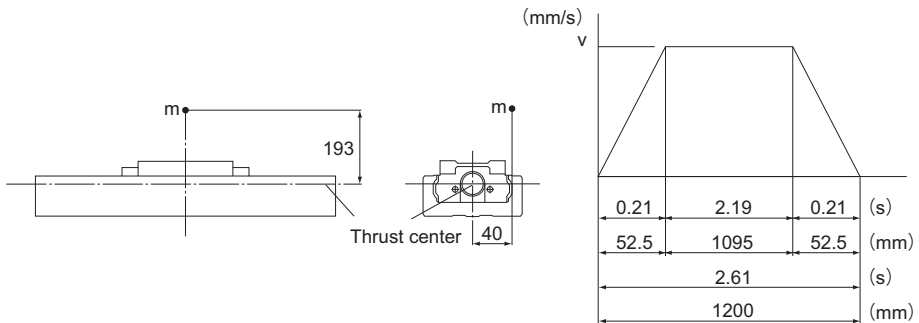

Fig.1 Velocity Diagram

[Consideration]

● Studying the LM Guide Unit

■ Load Applied to the Inner Block

* Assuming that a single inner block is used, convert applied moments M_A and M_B into applied load by multiplying them by the moment equivalent factor ($K_A = K_B = 8.63 \times 10^{-2}$).

* Assuming that a single shaft is used, convert applied moment M_C into applied load by multiplying it by the moment equivalent factor ($K_C = 2.83 \times 10^{-2}$).

- During uniform motion:

$$P_1 = mg + K_c \cdot mg \times 40 = 627 \text{ N}$$

- During acceleration:

$$P_{1a} = P_1 + K_A \cdot m\alpha \times 193 = 1826 \text{ N}$$

$$P_{1aT} = -K_B \cdot m\alpha \times 40 = -249 \text{ N}$$

- During deceleration:

$$P_{1d} = P_1 - K_A \cdot m\alpha \times 193 = -572 \text{ N}$$

$$P_{1dT} = K_B \cdot m\alpha \times 40 = 249 \text{ N}$$

* Since the groove under a load is different from the assumed groove, give "0" (zero) to P_{1aT} and P_{1dT} .

■ Combined Radial And Thrust Load

- During uniform motion:

$$P_{1E} = P_1 = 627 \text{ N}$$

- During acceleration:

$$P_{1aE} = P_{1a} + P_{1aT} = 1826 \text{ N}$$

- During deceleration:

$$P_{1dE} = P_{1d} + P_{1dT} = 249 \text{ N}$$

■ Static Safety Factor

$$f_s = \frac{C_0}{P_{\max}} = \frac{C_0}{P_{1aE}} = 33.9$$

■ Nominal Life

- Average load

$$P_m = \sqrt[3]{\frac{1}{\ell_s} (P_{1E}^3 \times 1095 + P_{1aE}^3 \times 52.5 + P_{1dE}^3 \times 52.5)} = 790 \text{ N}$$

- Nominal life

$$L = \left(\frac{C}{f_w \cdot P_m} \right)^3 \times 50 = 3.25 \times 10^6 \text{ km}$$

$$f_w \quad : \text{ Load factor} \quad (1.2)$$

● Studying the Ball Screw Unit

■ Axial load

- During forward uniform motion:

$$F_{a1} = \mu \cdot mg + f = 11 \text{ N}$$

μ : Friction coefficient(0.005)

f : Rolling resistance of one KR inner block + seal resistance(10.0 N)

- During forward acceleration:

$$F_{a2} = F_{a1} + m\alpha = 83 \text{ N}$$

- During forward deceleration:

$$F_{a3} = F_{a1} - m\alpha = -61 \text{ N}$$

- During uniform backward motion

$$F_{a4} = -F_{a1} = -11 \text{ N}$$

- During backward acceleration:

$$F_{a5} = F_{a4} - m\alpha = -83 \text{ N}$$

- During backward deceleration:

$$F_{a6} = F_{a4} + m\alpha = 61 \text{ N}$$

* Since the groove under a load is different from the assumed groove, give "0" (zero) to F_{a3} , F_{a4} and F_{a5} .

■ Static Safety Factor

$$f_s = \frac{C_{0a}}{F_{amax}} = \frac{C_{0a}}{F_{a2}} = 111.9$$

■ Buckling Load

$$P_1 = \frac{n \cdot \pi^2 \cdot E \cdot I}{l_a^2} \times 0.5 = 11000 \text{ N}$$

P_1 : Buckling load (N)

l_a : Distance between two mounting surfaces (1300 mm)

E : Young's modulus ($2.06 \times 10^5 \text{ N/mm}^2$)

n : Factor for mounting method (fixed-fixed: 4.0, see **■ 15-30**)

0.5 : Safety factor

I : Minimum geometrical moment of inertia of the shaft (mm^4)

$$I = \frac{\pi}{64} \cdot d_1^4$$

d_1 : Screw-shaft thread minor diameter (17.5 mm)

■ Permissible tensile Compressive Load

$$P_2 = \delta \cdot \frac{\pi}{4} \cdot d_1^2 = 35300 \text{ N}$$

P_2	: Permissible tensile compressive load	(N)
δ	: Permissible tensile compressive stress	(147 N/mm ²)
d_1	: Screw-shaft thread minor diameter	(17.5mm)

■ Dangerous Speed

$$N_1 = \frac{60 \cdot \lambda^2}{2\pi \cdot \ell_b^2} \cdot \sqrt{\frac{E \times 10^3 \cdot I}{\gamma \cdot A}} \times 0.8 = 1560 \text{ min}^{-1}$$

N_1	: Dangerous speed	(min ⁻¹)
ℓ_b	: Distance between two mounting surfaces	(1300mm)
γ	: Density	(7.85 × 10 ⁻⁶ kg/mm ³)
λ	: Factor according to the mounting method (fixed-supported 3.927, see A15-32)	
0.8	: Safety factor	

■ DN Value

$$DN = 31125 (\leq 50000)$$

D	: Ball center-to-center diameter	(20.75mm)
N	: Maximum working rotation speed	(1500min ⁻¹)

■ Nominal Life

- Average axial load

$$F_{am} = \sqrt[3]{\frac{1}{2 \cdot \ell_s} (F_{a1}^3 \times 1095 + F_{a2}^3 \times 52.5 + F_{a6}^3 \times 52.5)} = 26.2 \text{ N}$$

- Nominal life

$$L = \left(\frac{C_a}{f_w \cdot F_{am}} \right)^3 \cdot \ell = 3.05 \times 10^7 \text{ km}$$

f_w	: Load factor	(1.2)
ℓ	: Ball Screw lead	(20mm)

● **Bearing Unit (Fixed Side)**

■ **Axial Load (Same as the Ball Screw Unit)**

$$F_{a1} = 11 \text{ N}$$

$$F_{a2} = 83 \text{ N}$$

$$F_{a3} = 0 \text{ N}$$

$$F_{a4} = 0 \text{ N}$$

$$F_{a5} = 0 \text{ N}$$

$$F_{a6} = 61 \text{ N}$$

■ **Static Safety Factor**

$$f_s = \frac{P_{0a}}{F_{amax}} = \frac{P_{0a}}{F_{a2}} = 48.0$$

■ **Nominal Life**

● Average axial load

$$F_{am} = \sqrt[3]{\frac{1}{2 \cdot \ell_s} (F_{a1}^3 \times 1095 + F_{a2}^3 \times 52.5 + F_{a6}^3 \times 52.5)} = 26.2 \text{ N}$$

● Nominal life

$$L = \left(\frac{C_a}{f_w \cdot F_{am}} \right)^3 \times 10^6 = 1.41 \times 10^{13} \text{ rev}$$

$$f_w : \text{Load factor} \quad (1.2)$$

* Convert the above nominal life into the service life in travel distance of the Ball Screw.

$$L_s = L \cdot \ell \times 10^{-6} = 2.82 \times 10^8 \text{ km}$$

[Result]

The table below shows the result of the examination.

KR5520A	LM guide unit	Ball screw unit	Bearing unit (Fixed side)
Static safety factor	33.9	111.9	48.0
Buckling load(N)	—	11000	—
Permissible tensile compressive load(N)	—	35300	—
Dangerous speed(min ⁻¹)	—	1560	—
DN Value	—	31125	—
Nominal life(km)	3.25×10^8	3.05×10^7	2.82×10^8
Maximum working rotation speed(min ⁻¹)	—	1500	—

Note1) From the static safety coefficient and other values above, it is judged that the assumed model can be used.

Note2) Of the rated lives of the three components, the shortest value (of LM Guide unit) is considered the nominal life of the assumed model KR 5520A.

[Condition (Vertical Installation)]

Assumed model number	: KR 5520A
LM Guide Unit	($C = 38100 \text{ N}$, $C_0 = 61900 \text{ N}$)
Ball Screw Unit	($C_a = 3620 \text{ N}$, $C_{0a} = 9290 \text{ N}$)
Bearing Unit(Fixed Side)	($C_a = 7600 \text{ N}$, $P_{0a} = 3990 \text{ N}$)
Mass	: $m = 30 \text{ kg}$
Speed	: $v = 500 \text{ mm/s}$
Acceleration	: $\alpha = 2.4 \text{ m/s}^2$
Stroke	: $l_s = 1200 \text{ mm}$
Gravitational acceleration	: $g = 9.807 \text{ m/s}^2$
Velocity diagram	see Fig.2

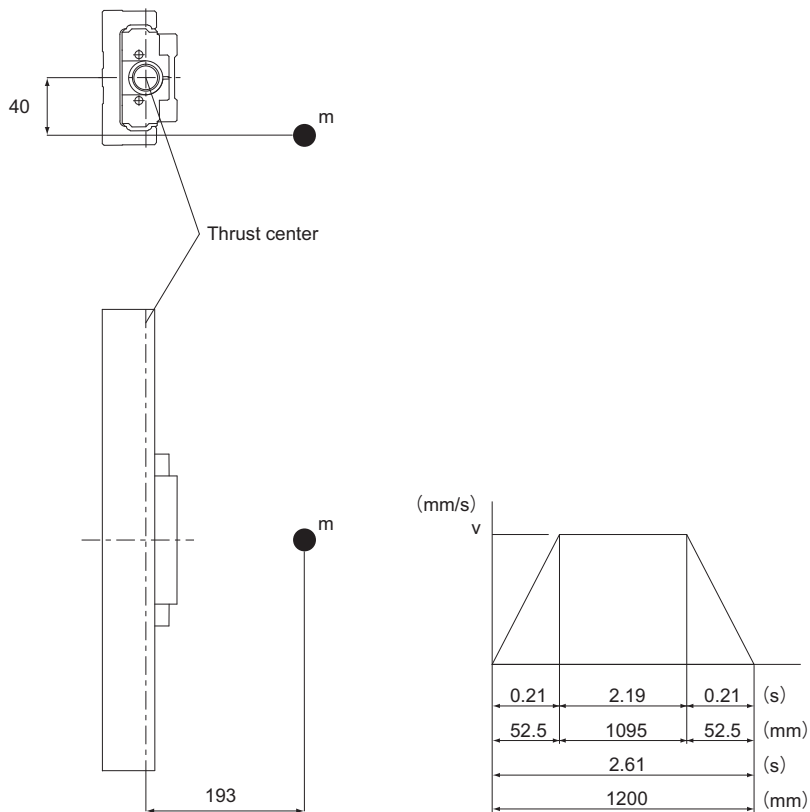

Fig.2 Velocity Diagram

[Consideration]● **Studying the LM Guide Unit**■ **Load Applied to the Inner Block**

* Assuming that a single inner block is used, convert applied moments M_A and M_B into applied load by multiplying them by the moment equivalent factor ($K_A = K_B = 8.63 \times 10^{-2}$).

- During uniform motion:

$$P_1 = K_A \cdot mg \times 193 = 4900 \text{ N}$$

$$P_{1T} = K_B \cdot mg \times 40 = 1016 \text{ N}$$

- During acceleration:

$$P_{1a} = P_1 + K_A \cdot m\alpha \times 193 = 6100 \text{ N}$$

$$P_{1aT} = P_{1T} + K_B \cdot m\alpha \times 40 = 1264 \text{ N}$$

- During deceleration:

$$P_{1d} = P_1 - K_A \cdot m\alpha \times 193 = 3701 \text{ N}$$

$$P_{1dT} = P_{1dT} - K_B \cdot m\alpha \times 40 = 767 \text{ N}$$

■ **Combined Radial And Thrust Load**

- During uniform motion:

$$P_{1E} = P_1 + P_{1T} = 5916 \text{ N}$$

- During acceleration:

$$P_{1aE} = P_{1a} + P_{1aT} = 7364 \text{ N}$$

- During deceleration:

$$P_{1dE} = P_{1d} + P_{1dT} = 4468 \text{ N}$$

■ **Static Safety Factor**

$$f_s = \frac{C_0}{P_{\max}} = \frac{C_0}{P_{1aE}} = 8.4$$

■ **Nominal Life**

- Average load

$$P_m = \sqrt[3]{\frac{1}{\ell_s} (P_{1E}^3 \times 1095 + P_{1aE}^3 \times 52.5 + P_{1dE}^3 \times 52.5)} = 5947 \text{ N}$$

- Nominal life

$$L = \left(\frac{C}{f_w \cdot P_m} \right)^3 \times 50 = 7.61 \times 10^3 \text{ km}$$

$$f_w : \text{Load factor} \quad (1.2)$$

● Studying the Ball Screw Unit

■ Axial Load

- During upward uniform motion:
 $F_{a1} = mg + f = 304 \text{ N}$
 f : Sliding resistance per block (10.0 N)
- During upward acceleration:
 $F_{a2} = F_{a1} + m\alpha = 376 \text{ N}$
- During upward deceleration:
 $F_{a3} = F_{a1} - m\alpha = 232 \text{ N}$
- During downward uniform motion:
 $F_{a4} = mg - f = 284 \text{ N}$
- During downward acceleration:
 $F_{a5} = F_{a4} - m\alpha = 212 \text{ N}$
- During downward deceleration:
 $F_{a6} = F_{a4} + m\alpha = 356 \text{ N}$

■ Static Safety Factor

$$f_s = \frac{C_{0a}}{F_{\max}} = \frac{C_{0a}}{F_{a2}} = 24.7$$

■ Buckling Load

Same as Horizontal Installation

■ Permissible Tensile Compressive Load

Same as Horizontal Installation

■ Dangerous Speed

Same as Horizontal Installation

■ DN Value

Same as Horizontal Installation

■ Nominal Life

- Average axial load

$$F_m = \sqrt[3]{\frac{1}{2 \cdot \ell_s} (F_{a1}^3 \times 1095 + F_{a2}^3 \times 52.5 + F_{a3}^3 \times 52.5 + F_{a4}^3 \times 1095 + F_{a5}^3 \times 52.5 + F_{a6}^3 \times 52.5)} = 296 \text{ N}$$

- Nominal life

$$L = \left(\frac{C_a}{f_w \cdot F_m} \right)^3 \times \ell = 2.11 \times 10^4 \text{ km}$$

f_w : Load factor (1.2) ℓ : Ball Screw lead (20mm)

● **Bearing Unit (Fixed Side)**

■ **Axial Load (Same as the Ball Screw Unit)**

$$F_{a1} = 304 \text{ N}$$

$$F_{a2} = 376 \text{ N}$$

$$F_{a3} = 232 \text{ N}$$

$$F_{a4} = 284 \text{ N}$$

$$F_{a5} = 212 \text{ N}$$

$$F_{a6} = 356 \text{ N}$$

■ **Static Safety Factor**

$$f_s = \frac{P_{0a}}{F_{\max}} = \frac{P_{0a}}{F_{a2}} = 10.6$$

■ **Nominal Life**

● **Average axial load**

$$F_m = \sqrt[3]{\frac{1}{2 \cdot \ell_s} (F_{a1}^3 \times 1095 + F_{a2}^3 \times 52.5 + F_{a3}^3 \times 52.5 + F_{a4}^3 \times 1095 + F_{a5}^3 \times 52.5 + F_{a6}^3 \times 52.5)} = 296 \text{ N}$$

● **Nominal life**

$$L = \left(\frac{C_a}{f_w \cdot F_m} \right)^3 \times 10^6 = 9.80 \times 10^9 \text{ rev}$$

$$f_w : \text{Load factor} \quad (1.2)$$

* Convert the above nominal life into the service life in travel distance of the Ball Screw.

$$L_s = L \cdot \ell \times 10^{-6} = 1.95 \times 10^5 \text{ km}$$

[Result]

The table below shows the result of the examination.

KR5520A	LM guide unit	Ball screw unit	Bearing unit (Fixed side)
Static safety factor	8.4	24.7	10.6
Buckling load(N)	—	11000	—
Permissible tensile compressive load(N)	—	35300	—
Dangerous speed(min ⁻¹)	—	1560	—
DN Value	—	31125	—
Nominal life(km)	7.61 × 10 ³	2.11 × 10 ⁴	1.95 × 10 ⁵
Maximum working rotation speed(min ⁻¹)	—	1500	—

Note1) From the static safety coefficient and other values above, it is judged that the assumed model can be used.

Note2) Of the rated lives of the three components, the shortest value (of LM Guide unit) is considered the nominal life of the assumed model KR 5520A.

Options

LM Guide Actuator (Options)

Various types of options are available for models SKR and KR. Select an appropriate model according to your application. There are also options not contained in this catalog. Contact THK for details.

Name		Overview
Cover	Cover	Serve as contamination protection accessories or the likes
	Bellows	
Sensor	Proximity sensor	Supporting manufacturers: Azbil Corp., Panasonic Industrial Devices SUNX Co., Ltd.
	Photo sensor	Supporting manufacturer: Omron
	Sensor rail	For mounting a sensor
Motor bracket	Housing A with a separate motor/wrap-around housing	If the customer provides a motor bracket and a motor wrap-around section
	Intermediate Flange	Supporting manufacturer: Yaskawa Electric, Mitsubishi Electric, Panasonic, Sanyo Electric, Omron, Fanuc, Keyence and Oriental Motor

Table1 Table of Applicable Options

Model No.	Cover	Bellows	Proximity sensor	Photo sensor	Housing A for a Separate Motor	Turnaround Housing A	Intermediate Flange
SKR20	○	○	○	○	—	△	○
SKR26	○	○	○	○	—	△	○
SKR33	○	○	○	○	—	△	○
SKR46	○	○	○	○	—	△	○
SKR55	○	○	○	○	—	○	○
SKR65	○	○	○	○	—	○	○
KR15	○	○	○	—	—	△	○
KR20	○	○	○	○	—	—	○
KR26	○	○	○	○	—	—	○
KR30H	○	○	○	○	—	△	○
KR33	○	○	○	○	○	○	○
KR45H	○	○	○	○	—	△	○
KR46	○	○	○	○	○	○	○
KR55	○	○	○	○	—	○	○
KR65	○	○	○	○	—	○	○

△ : There are also options not contained in this catalog. Contact THK for details.

Cover

- For the dimensions of models SKR and KR with covers attached, see [A Product Descriptions](#).

For models SKR and KR, covers are available as an option.

[Example of Installation]

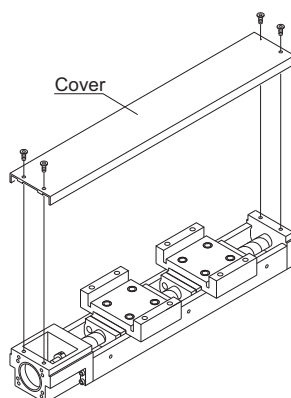

Model SKR33(with a Cover)

Bellows

- For dimensions of the bellows, see [A2-47 to A2-51](#) and [A2-125 to A2-130](#).

For models SKR and KR, bellows are available for contamination protection in addition to a cover.

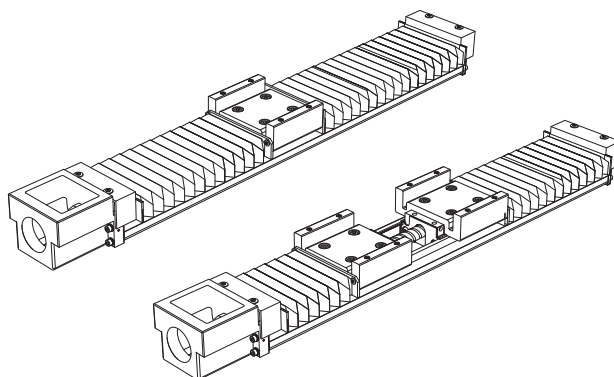

Sensor

● For detailed dimensions, see [A2-52 to A2-55](#) and [A2-131 to A2-134](#).

Optional proximity and photo sensors are available for models SKR and KR.

[Installed Example]

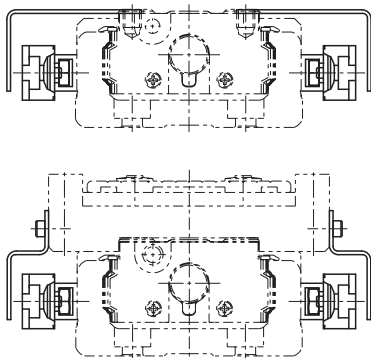

Housing

● For detailed dimensions, see [A2-56 to A2-72](#) and [A2-135 to A2-163](#).

THK also offers Housing A provided with a separate motor, and a turnaround type of Housing A, as options in order to support a motor bracket or a turnaround section that the customer may separately produce.

[Housing A for a Separate Motor]

By using the fitting difference, the user can easily mount a separately manufactured motor bracket.

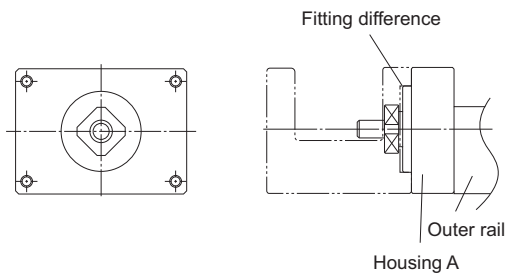

Options

Motor Wrap Type

[Turnaround Housing A]

Since the mounting holes are drilled in constant pitches, the user can easily select a direction to mount the turnaround section.

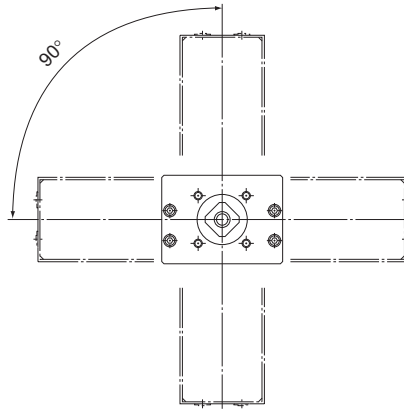

Motor Wrap Type

Models SKR and KR are available in "Motor Wrap" types that allow the motor to be turned around in order to minimize the dimension in the longitudinal direction (Pulley ratio:1:1). Contact THK for details.

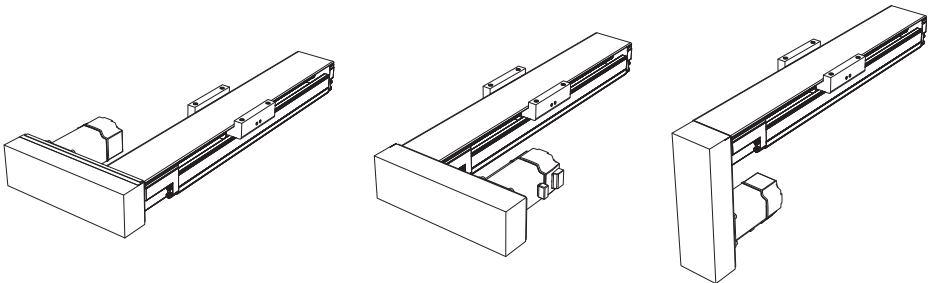

XY Bracket (for Reference)

Brackets for installing models SKR33/46 and models KR33/46 are available. The brackets use aluminum to reduce the weights and keep the inertia as low as possible.

Model No.

LM Guide Actuator

Model No.	Ball Screw Lead	Inner block type	Stroke	Accuracy
SKR33	10	A	0195	P

①

②

③

④

⑤

SKR20	01 : 1mm	A	0025 : 25mm	No symbol: normal grade H : High accuracy grade P : Precision Grade
SKR26	02 : 2mm	B	0050 : 50mm	
SKR33	06 : 6mm	C	∟	
SKR46	10 : 10mm	D	1490 : 1490mm	
SKR55	20 : 20mm			
SKR65	25 : 25mm			
	30 : 30mm			
KR15	40 : 40mm			
KR20	50 : 50mm			
KR26				
KR30H				
KR33				
KR45H				
KR46				
KR55				
KR65				

If "2" (with Bellows) was selected for the cover ⑦, specify a stroke incorporating the bellows (→ **A2-47** **A2-125**).

The available ball screw leads differ depending on the model.

SKR20 : "01", "06"

SKR26 : "02", "06"

SKR33 : "06", "10", "20" (20 mm available for inner block A and B only)

SKR46 : "10", "20"

SKR55 : "20", "30", "40"

SKR65 : "20", "25", "30", "50"

KR15 : "01", "02"

KR20 : "01", "06"

KR26 : "02", "06"

KR30H : "06", "10"

KR33 : "06", "10"

KR45H : "10", "20"

KR46 : "10", "20"

KR55 : "20"

KR65 : "25"

With/without a motor	Cover	Sensor	Housing A/ Intermediate Flange																																												
0	1	B	AQ																																												
⑥	⑦	⑧	⑨																																												
<table border="1"> <tr> <td>0: direct-coupled (without a motor)</td> </tr> <tr> <td>1: direct-coupled (with a motor, specified by the customer)</td> </tr> </table>	0: direct-coupled (without a motor)	1: direct-coupled (with a motor, specified by the customer)	<table border="1"> <tr> <td>0: without a cover</td> </tr> <tr> <td>1: with a cover</td> </tr> <tr> <td>2: with a bellows</td> </tr> </table>	0: without a cover	1: with a cover	2: with a bellows	<table border="1"> <tr> <td>0: none</td> <td>10</td> </tr> <tr> <td>1</td> <td>20</td> </tr> <tr> <td>2</td> <td>30</td> </tr> <tr> <td>6</td> <td>40</td> </tr> <tr> <td>7</td> <td>50 (KR only)</td> </tr> <tr> <td>B</td> <td>60</td> </tr> <tr> <td>E</td> <td>A0</td> </tr> <tr> <td>H</td> <td>A5</td> </tr> <tr> <td>L</td> <td>A6</td> </tr> <tr> <td>J</td> <td>AM</td> </tr> <tr> <td>M</td> <td>AN</td> </tr> <tr> <td></td> <td>AP</td> </tr> <tr> <td></td> <td>AQ</td> </tr> <tr> <td></td> <td>AR</td> </tr> <tr> <td></td> <td>AS</td> </tr> <tr> <td></td> <td>AT</td> </tr> <tr> <td></td> <td>AU</td> </tr> <tr> <td></td> <td>AV</td> </tr> <tr> <td></td> <td>AY</td> </tr> <tr> <td></td> <td>AZ</td> </tr> </table>	0: none	10	1	20	2	30	6	40	7	50 (KR only)	B	60	E	A0	H	A5	L	A6	J	AM	M	AN		AP		AQ		AR		AS		AT		AU		AV		AY		AZ
0: direct-coupled (without a motor)																																															
1: direct-coupled (with a motor, specified by the customer)																																															
0: without a cover																																															
1: with a cover																																															
2: with a bellows																																															
0: none	10																																														
1	20																																														
2	30																																														
6	40																																														
7	50 (KR only)																																														
B	60																																														
E	A0																																														
H	A5																																														
L	A6																																														
J	AM																																														
M	AN																																														
	AP																																														
	AQ																																														
	AR																																														
	AS																																														
	AT																																														
	AU																																														
	AV																																														
	AY																																														
	AZ																																														
<p>If "0" is selected, a coupling is not attached. If a coupling is required, please indicate so.</p> <p>"1" means that a motor specified by the customer is mounted. For item ⑨, select a housing A/intermediate flange that matches the specified motor.</p>																																															
<p>Several motors by different manufacturers can be mounted. Contact THK for details.</p>																																															

A type with a wrap-around housing A and a motor wrap-around type, which are not contained in the catalog, are also available. Contact THK for details.

[Handling]

- (1) Do not disassemble the parts. This will result in loss of functionality.
- (2) Take care not to drop or strike the parts. Doing so may cause injury or damage. Giving an impact to it could also cause damage to its function even if the product looks intact.
- (3) When handling the product, wear protective gloves, safety shoes, etc., as necessary to ensure safety.

[Precautions on Use]

- (1) Prevent foreign material, such as cutting chips or coolant, from entering the product. Failure to do so may cause damage.
- (2) If the product is used in an environment where cutting chips, coolant, corrosive solvents, water, etc., may enter the product, use bellows, covers, etc., to prevent them from entering the product.
- (3) If foreign material such as cutting chips adheres to the product, replenish the lubricant after cleaning the product.
- (4) The service temperature range of this product is 0 to 40°C (no freezing or condensation). If you consider using this product outside the service temperature range, contact THK.
- (5) Exceeding the dangerous speed may lead the components to be damaged or cause an accident. Be sure to use the product within the specification range designated by THK.
- (6) Micro-strokes tend to obstruct oil film to form on the raceway in contact with the rolling element, and may lead to fretting corrosion. Take consideration using grease offering excellent fretting prevention. It is also recommended that a stroke movement corresponding to the length of the nut block be made on a regular basis to make sure oil film is formed between the raceway and rolling element.
- (7) Do not use undue force when fitting parts (pin, key, etc.) to the product. This may generate permanent deformation on the raceway, leading to loss of functionality.
- (8) If the product is operating or in the ready state, never touch a moving part. In addition, do not enter the operating area of the actuator.
- (9) If two or more people are involved in the operation, confirm the procedures such as a sequence, signs and anomalies in advance, and appoint another person for monitoring the operation.
- (10) Insufficient rigidity or accuracy of mounting members causes the bearing load to concentrate on one point and the bearing performance will drop significantly. Accordingly, give sufficient consideration to the rigidity/accuracy of the housing and base and strength of the fixing bolts.

[Lubrication]

- (1) Thoroughly wipe off the anti-rust oil before using the product.
- (2) Lubrication is needed to let the models KR/SKR demonstrate their functions fully. Using the product without sufficient lubrication may increase wear of the rolling elements or shorten the service life. Note the standard grease used in the product as follows.

Model KR15	THK AFF Grease
Models SKR20, SKR26, KR20, KR26	THK AFA Grease
Models SKR33, SKR46, SKR55, SKR65, KR30H, KR33, KR45H, KR46, KR55, KR65	THK AFB-LF Grease

- (3) Do not mix different lubricants. Mixing greases using the same type of thickening agent may still cause adverse interaction between the two greases if they use different additives, etc.
- (4) When using the product in locations exposed to constant vibrations or in special environments such as clean rooms, vacuum and low/high temperature, use the grease appropriate for the specification/environment.
- (5) When adopting oil lubrication method, contact THK.
- (6) Because the intervals between greasing vary depending on the conditions of product use, it is recommended that the greasing interval be determined through an initial inspection. Although the lubrication interval may vary according to use conditions and the service environment, lubrication should be performed approximately every 100 km in travel distance (three to six months). Set the final lubrication interval/amount based on the actual machine.
- (7) The consistency of grease changes according to the temperature. Take note that the slide resistance of the models KR/SKR also changes as the consistency of grease changes.
- (8) After lubrication, the slide resistance of the models KR/SKR may increase due to the agitation resistance of grease. Be sure to perform a break-in to let the grease spread fully, before operating the machine.
- (9) Excess grease may scatter immediately after lubrication, so wipe off scattered grease as necessary.
- (10) The properties of grease deteriorate and its lubrication performance drops over time, so grease must be checked and added properly according to the use frequency of the machine.

[Storage]

When storing the models KR/SKR, enclose them in a package designated by THK and store them in a room in a horizontal orientation while avoiding high temperature, low temperature and high humidity.

After the product has been in storage for an extended period of time, lubricant inside may have deteriorated, so add new lubricant before use.

[Disposal]

Dispose of the product properly as industrial waste.

[Instruction Manual]

You can download the “LM Guide Actuator Models KR/SKR -- Instruction Manual” from the THK technical support website.

Technical support website: <https://tech.thk.com/>

