

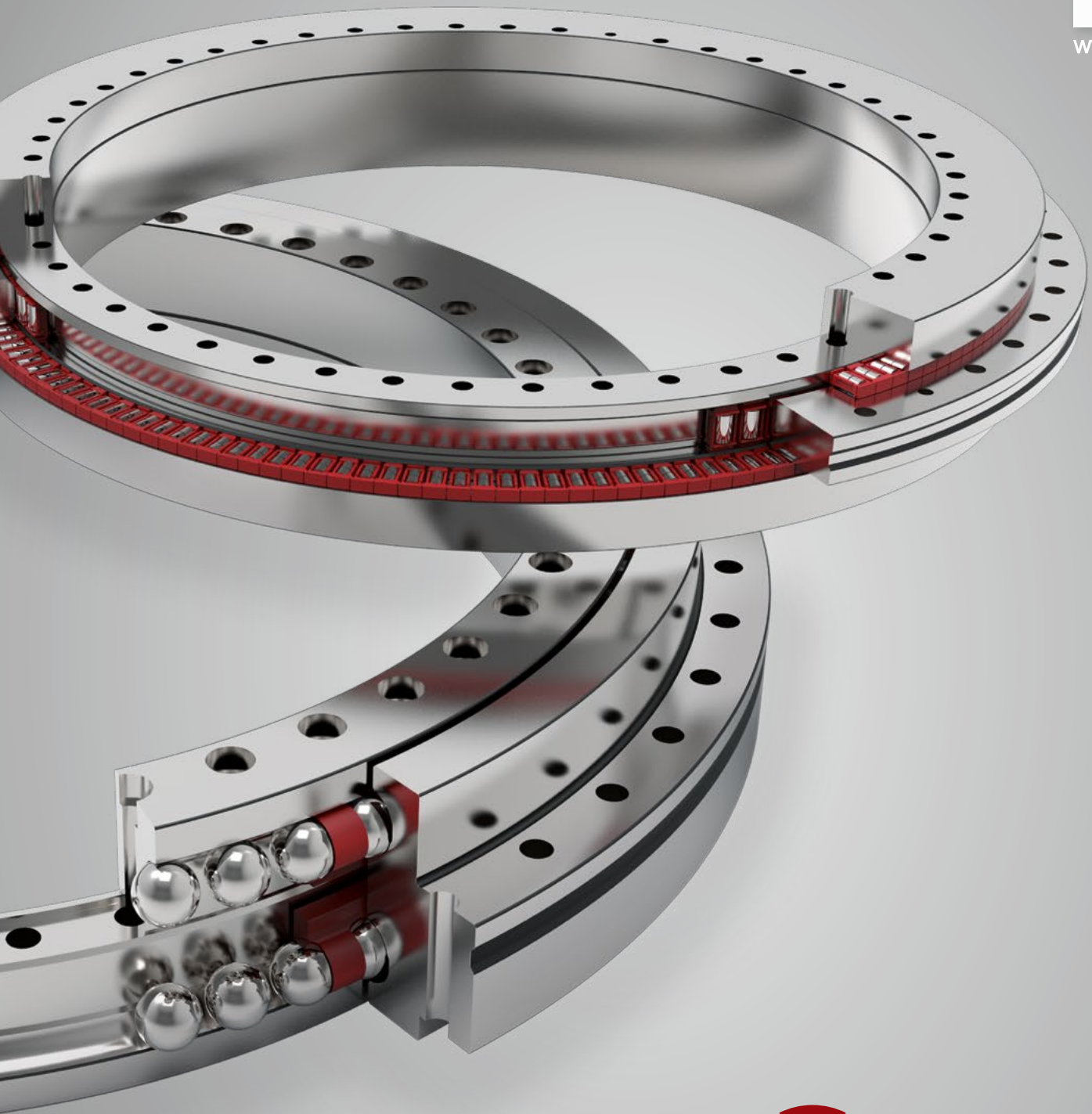



[www.krw.de](http://www.krw.de)



**ROTAB<sup>®</sup>**

The new excellence class  
of rotary table bearings



All data have been prepared with a great deal of care and checked for their accuracy. However, no liability can be assumed for any incorrect or incomplete data. We reserve the right to make technical modifications.

© KRW Leipzig GmbH

Issued: 2017, September

# The Kugel- und Rollenlagerwerk Leipzig GmbH

Evolved from the company "Deutsche Kugellagerfabrik" (DKF) we belong to the pioneers of the bearing industry. Since 1993 we operate as Kugel- und Rollenlagerwerk Leipzig GmbH. About 220 highly qualified and motivated employees manufacture our quality bearings - Made in Germany.

Flexible and focused on the needs of our customers, we deliver our bearing solutions to companies in a wide range of industries, worldwide. Advanced manufacturing technologies, experienced engineers and continuous research on the further development of our products make us the innovative specialist for rolling bearings that we are today.

In recent years, we developed from a supplier of high precision standard bearings in the field of machine tools to a system provider of innovative bearing solutions. KRW offers, in addition to spindle bearings for large turning or grinding machines, a wide range of rotary table bearings and customized special solutions. Based on the wishes of our customers for more turning speed, lower friction and higher process reliability, we developed the new ROTAB ® Series for rotary tables. On the following pages we present our product range of KRW ROTAB ® Bearings as well as all information on their installation and use.

KRW – Precision made in Germany



# ROTAB®

The new excellence class  
of rotary table bearings

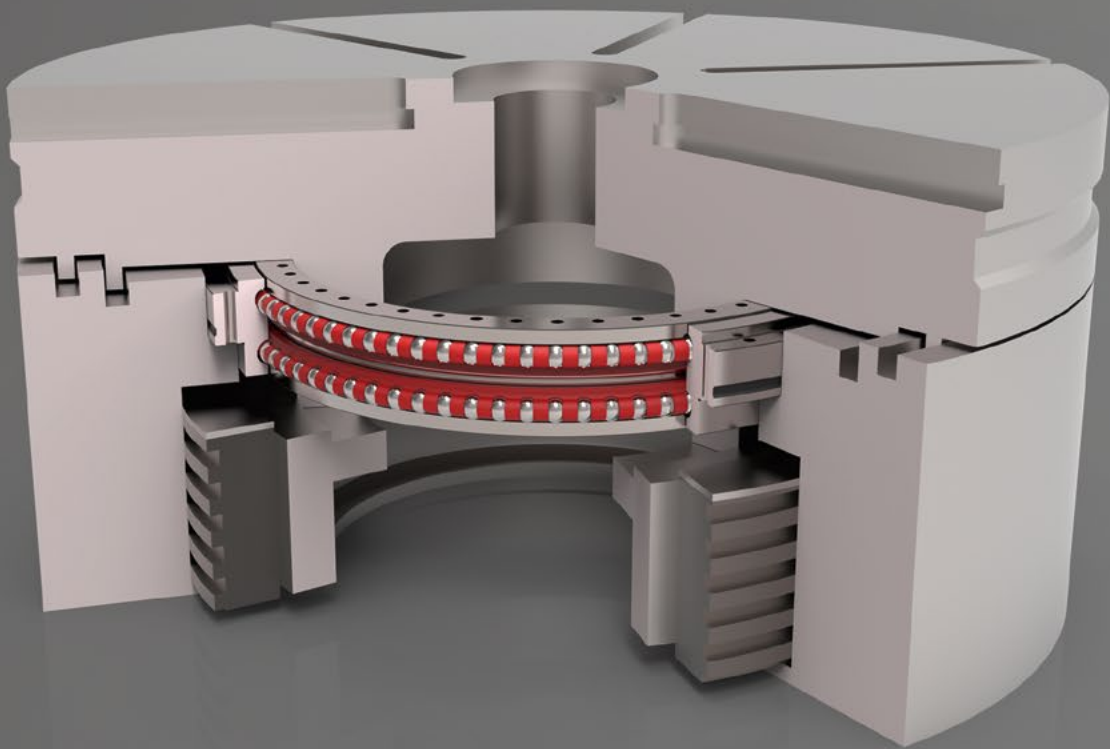

Rotary table bearings of KRW ROTAB series are high precision roller bearings for the most challenging processing tasks for machine tools. The ready to install, pre-loaded and greased bearing units support combined axial and radial loads as well as bending moments. With the ROTAB series KRW offers the first modular and interchangeable single-bearing solution within the segment of large rotary table bearings for heavy milling and high-speed turning.

## ROTAB® ARS

The consequent further development of the proven axial-radial bearing combines the high rigidity and load capacity of this bearing type with considerably increased rotational speed. The entirely new developed inner geometry of the ROTAB ARS combined with a special roller design and super finished surfaces reduces the frictional moment by up to 50% compared to established competing products. Furthermore, the smart cage design reliably prevents lubricating grease loss even at high rotational speeds. This significantly reduces lubricant consumption and improves operational reliability. Associated downtime due to lubrication intervals is considerably reduced.

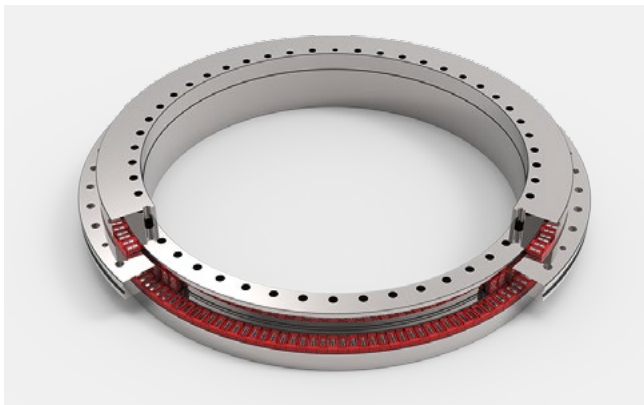

## ROTAB® DBS

The ROTAB DBS sets a new standard for high-speed machine tool bearings. The pre-loaded, double directional ball bearing unit is able to reach extreme speeds and offers sufficient rigidity, even for challenging milling tasks. Thanks to the sophisticated design and the high accuracy of the bearing, the friction moment is significantly reduced compared to a conventional axial-radial bearing. This results in very low self-heating of the system in addition to considerable energy savings during the machine operating time. Therefore a simple to realise grease lubrication is adequate for almost every application. This reduces the costs of the table design as well as the maintenance effort for high-speed rotary tables significantly.



## ROTAB® AR

For standard applications on lower-speed rotary tables, the ROTAB series also offers the classic version of the axial-radial bearing.

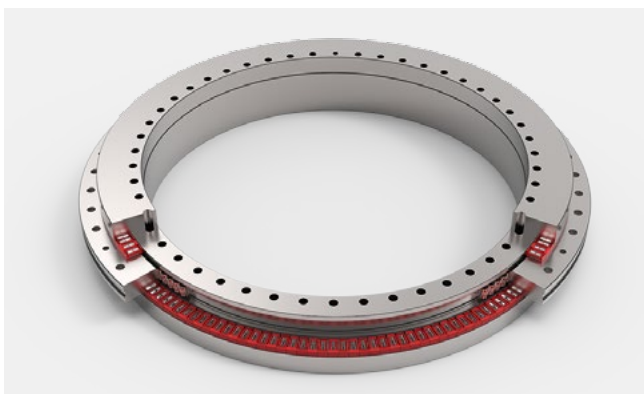

# Model and Suffixes

## Standard model

### ROTAB® AR/ROTAB® ARS

In the standard configuration, both bearing types come with a lithium complex soap grease on a partially synthetic oil base. The high pressure absorption capacity of this grease also guarantees a stable lubricating film and low-wear running even with heavy loads. Relubrication is done by using the three relubrication holes on the outer ring.

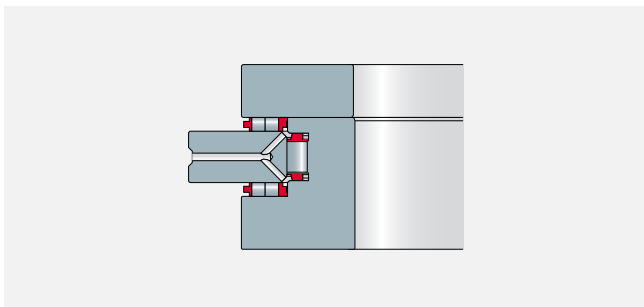

Lubrication hole ROTAB® ARS

### ROTAB® DBS

In the standard configuration, the bearing unit comes with a lithium complex soap grease with a partially synthetic oil base. The low-viscosity oil (NLGI class 2 grease) guarantees minor frictional torque and thus less self-heating, even in the case of high speeds. Relubrication is done by using the three relubrication holes on the outer ring.

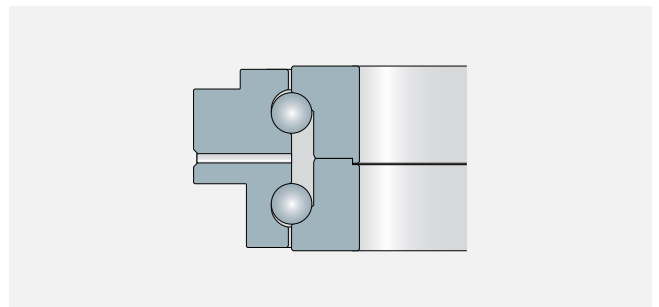

Lubrication hole ROTAB® DBS

## ordering example

### ROTAB® DBS 850

ROTAB® DBS 850 standard design

### ROTAB® ARS 650.SIR3.H1.VU

ROTAB® ARS 650 with 3 additional radial lubrication holes in the inner ring, constricted connection dimension H1, and a preload match for a supported L-section ring.

# Suffixes

Model (design)	Suffix	Description
Three radial relubrication holes in the outer ring	Standard	
Three additional radial relubrication holes in the inner ring	SIR3	
One additional, planar-side relubrication hole in the outer ring <i>( Information to axial positionings for SARP1 see page 12 )</i>	SARP1	
Two additional, flat-sided relubrication holes in the outer ring, on both sides next to the locating pin hole / raceways can be lubricated separately <i>( Information to axial positionings for SARP2 see page 12 )</i>	SARP2	
Six additional, flat-sided relubrication holes in the outer ring distributed by 60° / raceways can be lubricated separately <i>( Information to axial positionings for SARP6 see page 12 )</i>	SARP6	
Axial and radial runout tolerance restricted by 50 %	PR50	Axial and radial runout tolerances according to table „bearing tolerances“ restricted by 50 %
Constricted connection dimension H1	H1	Connection dimension according to table „bearing tolerances“ restricted
Constricted connection dimension H1	H2	Connection dimension according to table „bearing tolerances“ restricted
Bearing preload for installation with supported L-section ring	VU	
Bearing preload customized, specific to application	VAX.VRY	X corresponds to individual axial preload in $\mu\text{m}$ Y corresponds to individual radial preload in $\mu\text{m}$
Ungreased bearings	L0	Bearing is delivered in an ungreased, preserved condition
Individual specifications	FV5XX	Customization

## Design of the adjacent construction

Proper design and precision manufacturing of the adjacent construction are prerequisites for taking full advantage of the bearing's precision and running characteristics within the rotary table. Along with optimal selection of fitting, it is necessary to manufacture all the surrounding parts according to the corresponding exact tolerances for shape and position. Depending on the specifications, it must be determined which precision grade, is needed for the bearing (normal tolerance or constricted axial and radial runout suffix PR50) and whether the inner ring or outer ring represents the rotating component of the bearing.

Generally, it is important to note:

- Fit interferences that are too large increase the preload and, as a result, the friction of the bearing. Higher frictional power leads to higher self-heating and, therewith, to a restriction of the bearing's turning speed.
- Too large fitting tolerance, particularly on the rotating ring, can impair the radial runout of the table. Dimensional modifications during operation caused by temperature differences between the inner and outer ring can also lead to constraining forces of the screw connection between bearing and the adjacent construction.

We recommend designing the shape and position tolerances of the adjacent geometry for the standard design of the ROTAB series according to the following tables. If there are even more exact specifications for the bearing's axial and radial runout, then the design and manufacturing must be that much more precise.

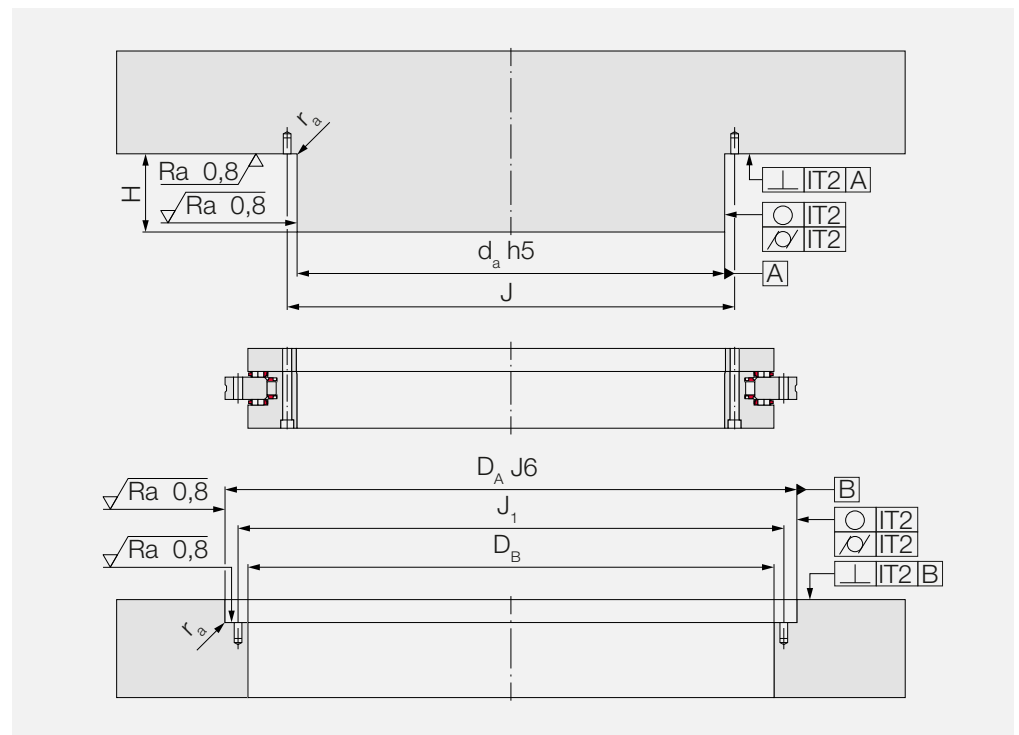

Shape and position tolerances of the mating parts



## Shaft Tolerances

In general, all bearings in the ROTAB series must be supported on the full length of the inner diameter. For the slowly rotating standard bearing ROTAB AR it is sufficient to set the shaft tolerance according to tolerance class h5. In the case of suboptimal tolerances, a too high interference value leading to an increase of the bearing preload.

For high-speed ROTAB ARS and ROTAB DBS bearings, it is necessary to achieve a near-zero fitting tolerance for the bearing's full rotational ability. All of the ROTAB series bearings are delivered including a measurement report with the actual value for the bore diameter according to, the shaft tolerance can be established. Bearings with special tolerances are possible upon request.

Shaft diameter		Shape and position tolerances	Edge radius
$d_a$	h5	IT2	$r_a$ max.
[mm]	[mm]	[mm]	[mm]
200	-0,02	0,007	0,1
260	-0,023	0,008	0,3
325	-0,025	0,009	0,3
395	-0,025	0,009	0,3
460	-0,027	0,01	1
580	-0,032	0,011	1
650	-0,036	0,013	1
850	-0,04	0,015	1
950	-0,04	0,015	1
1030	-0,047	0,018	1

shaft tolerances /rotating inner ring

## Housing Fit

The outer ring is mainly mounted in the casing and represents the stationary part of the bearing. In this case, a J6 fit is recommended for exact centering. In most cases involving mounting an H7 fit is also sufficient. However, it must be noted that a tightly fitting outer ring (press fit), caused by the heating up of the bearing while in operation, can very quickly lead to a high preload.

For applications in which the outer ring rotates, it is necessary to have a near-zero fitting tolerance for the highest precision in radial runout. All of the ROTAB series bearings come with a measurement report with the actual value of the bore hole, according to which the casing or housing fit can be established. Bearings with special tolerances are possible upon request.

Housing bore hole		Shape and position tolerances	Edge radius
$D_A$	J6	IT2	$r_a$ max.
[mm]	[mm]	[mm]	[mm]
300	+0,025/-0,007	0,008	0,1
385	+0,029/-0,007	0,009	0,3
450	+0,033/-0,007	0,01	0,3
525	+0,034/-0,010	0,011	0,3
600	+0,034/-0,010	0,011	1
750	+0,038/-0,012	0,013	1
870	+0,044/-0,012	0,015	1
1095	+0,052/-0,014	0,018	1
1200	+0,052/-0,014	0,018	1
1300	+0,052/-0,014	0,018	1

shaft tolerances /rotating outer ring

# Mounting

The bearing rings with the shaft and housing are to be tightened crosswise in three steps according to the following diagram. Note that all KRW ROTAB series bearings are delivered with 2 retaining screws. These must be loosened when installing the bearing and included in the screw tightening process.

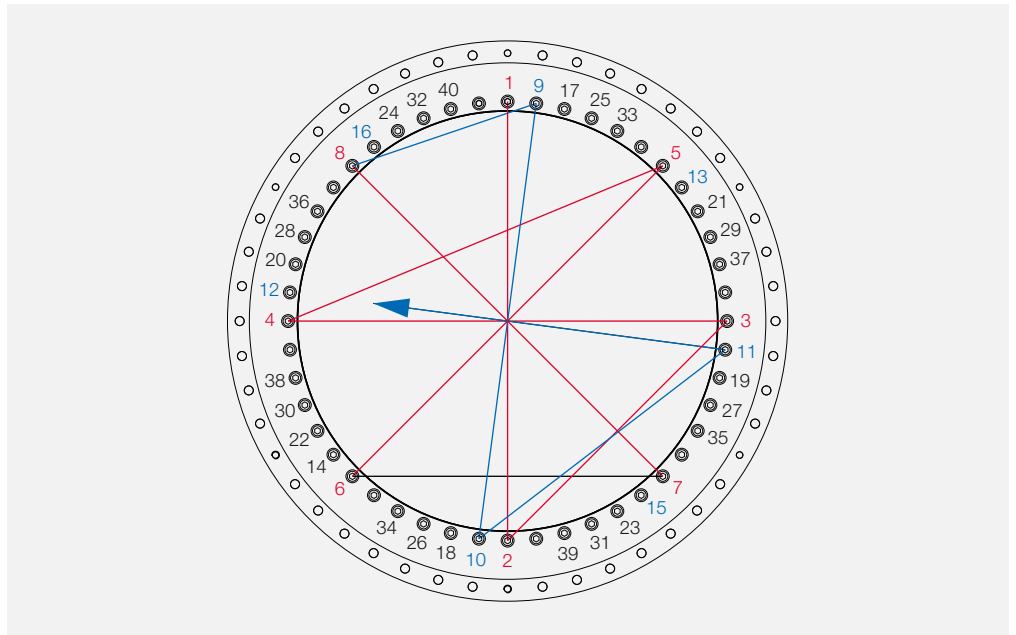

## Screw tightening

The related tightening torques can be found in the following table. To realize these torques, screws of strength class 10.9 must be used.

The threads for the retaining screws are designed as thread inserts. The user has the option of removing these and using the resulting through-bores for two other fixing screws. This option is recommended for high bearing speeds.

Bearing bore diameter [mm]	Screw size [-]	First step [Nm]	Second step [Nm]	Third step [Nm]
200	M6	6	10	14
260	M8	14	24	34
325	M8	14	24	34
395	M8	14	24	34
460	M8	14	24	34
580	M10	27	48	68
650	M12	46	81	116
850	M16	114	199	284
950	M16	114	199	284
1030	M16	114	199	284

## Overview tightening torques

## Grease distribution

When using grease lubricated ROTAB series bearings, a grease distribution cycle should be run according to the following cycle prior to commissioning.

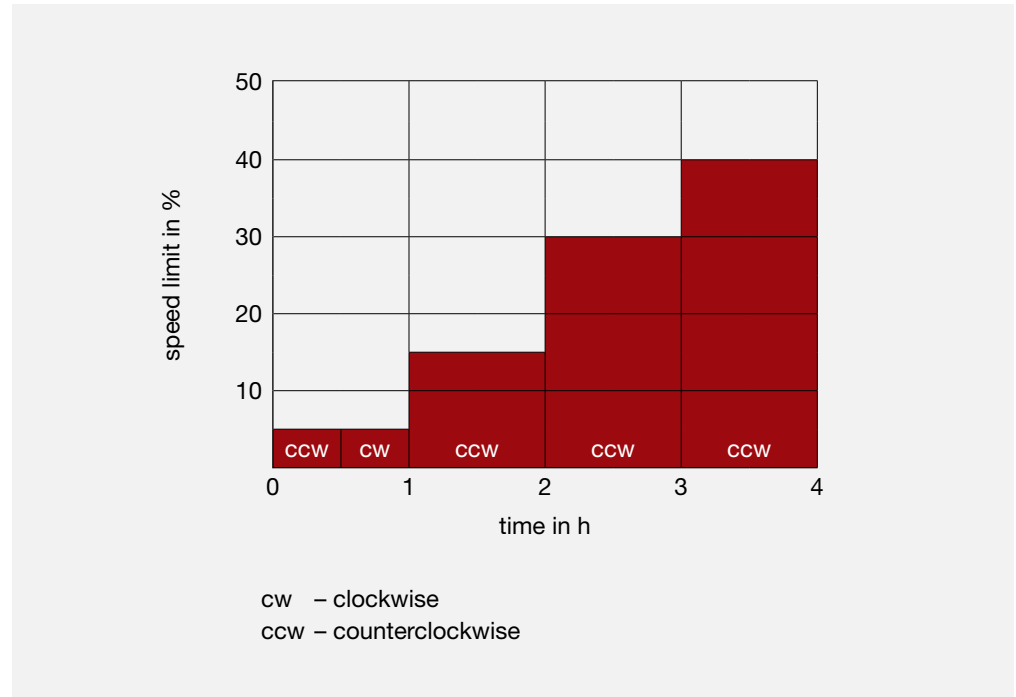

### Grease distribution

Depending on speed and duty cycle, relubrication is necessary for all ROTAB bearings filled with grease. Basically it should be noted that the frictional torque increases due to the added grease. For this reason, a grease distribution cycle is also required after every relubrication. The length of the regreasing intervals can vary widely depending on application and usage.

In the case of very slow rotating milling machine tables or slewing axes, the grease distribution cycle can be skipped depending on the experience level of the user. For high-speed applications it is advisable to use an automated regreasing unit. Connection to the machine control system, it allows to add the optimal amount of lubricant without the risk of overlubricating the bearings or needing to interrupt machine operation.

For more information on lubrication, please contact our Application Technology Team.

## Pilot Pin Bore Hole

KRW ROTAB bearings have pilot pin bore holes for correct positioning of the planar side lubrication holes (suffix SARP1, SARP2, SARP6). The corresponding bore holes in the housing can be done, by using the following dimensions.

Shaft diameter		Pin hole diameter	Pin hole height	Pilot pin bore hole diameter	Pilot pin bore hole depth
d over	up to	max.	max.		min.
[mm]	[mm]	[mm]	[mm]	[mm]	[mm]
-	460	4	4	5	5
460	580	6	6	8	8
580	-	8	8	10	10

Pilot pin bore hole

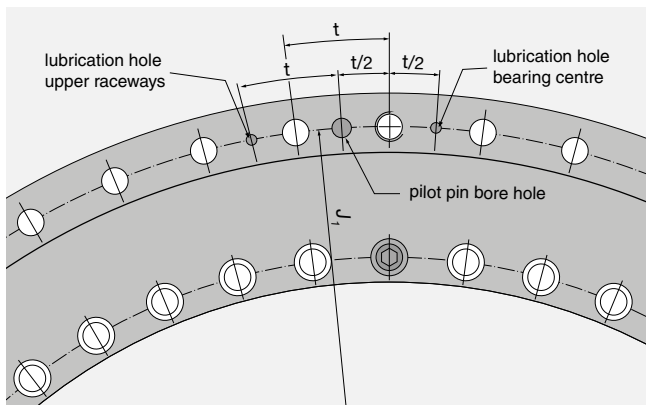

Position lubrication hole SARP2

The dimensions J1 and t can be found in the measurement charts.

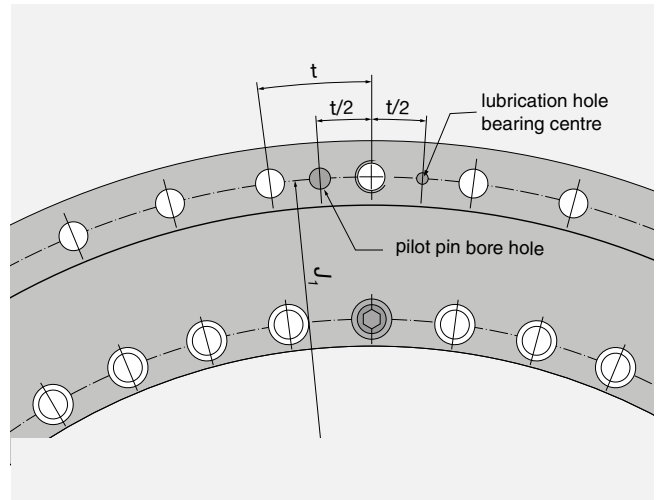

Position lubrication hole SARP1

The dimensions J1 and t can be found in the measurement charts.

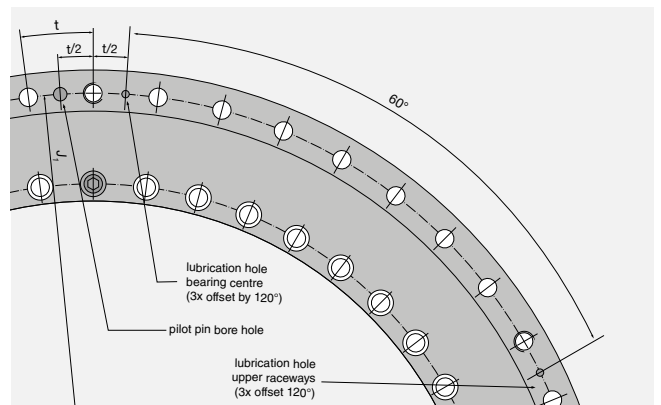

Position lubrication hole SARP6

The dimensions J1 and t can be found in the measurement charts.

## Lubrication

### Speed Limits

The rotation speed limits given in the catalogue are to be understood as mechanical maximum rotation speeds. In almost all cases the possible rotation speed will be determined by the heating of the bearing. Due to the design, the ROTAB AR and ROTAB ARS bearings produce much higher frictional torque than the ROTAB DBS that are designed for high-speed applications. When using standard bearing designs including greasing, it is recommended not to operate ROTAB AR and ARS over 60°C and ROTAB DBS over 50°C.

In these cases active, adjustable cooling of both bearing rings and the use of a heat-dissipating oil lubrication is necessary. Due to the large bearing reference circle and the rigid inner construction, all larger axial/radial bearings react sensitively to temperature differences between the inner and outer ring. This can result from the load, the driving unit or heat flows from other surrounding parts, and can vary over the range of speeds. If, particularly for new constructions, attention is paid to even temperature distribution, it is possible to achieve permanently high speeds without the typical cooling phases. Our application technology engineers are available to assist with any questions.

# Bearing Tolerances

The standard designs of the KRW ROTAB bearings are manufactured according to DIN 620, dimensional tolerances P5, and running tolerances P4. All further specifications can be found in the following size chart.

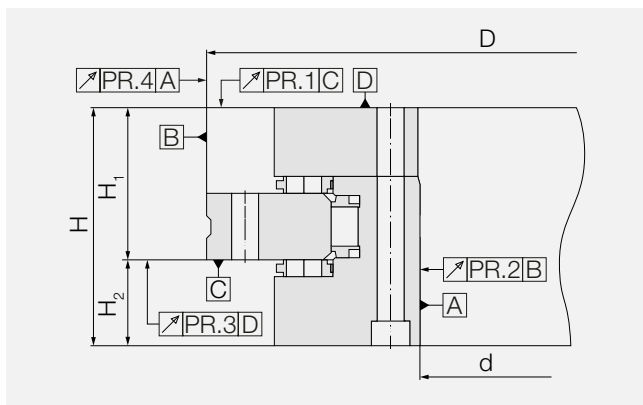

ROTAB® ARS/AR

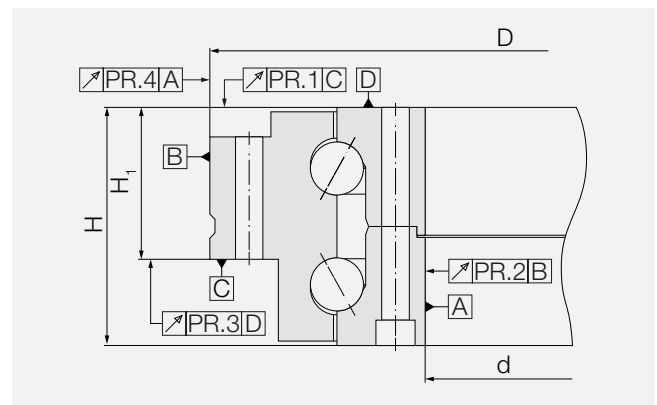

ROTAB® DBS

Dimensional tolerances				Height tolerances						Axial and radial runout	
Bore diameter		Outer diameter		Height	Standard	Constricted	Height	Standard	Constricted	Standard	Constricted
d		D		H <sub>1</sub>		.H <sub>1</sub>	H <sub>2</sub>		.H <sub>2</sub>	PR	.PR50
[mm]	[mm]	[mm]	[mm]	[mm]	[mm]	[mm]	[mm]	[mm]	[mm]	[mm]	[mm]
200	-0,015	300	-0,018	30	±0,175	±0,03	15	±0,175	±0,025	0,004	-
260	-0,018	385	-0,02	36,5	±0,2	±0,04	18,5	±0,2	±0,025	0,006	-
325	-0,023	450	-0,023	40	±0,2	±0,05	20	±0,2	±0,025	0,006	-
395	-0,023	525	-0,028	42,5	±0,2	±0,05	22,5	±0,2	±0,025	0,006	-
460	-0,023	600	-0,028	46	±0,225	±0,06	24	±0,225	±0,03	0,006	-
580	-0,025	750	-0,035	60	±0,25	±0,075	30	±0,25	±0,03	0,01	0,005
650	-0,038	870	-0,05	78	±0,25	±0,1	44	±0,25	±0,03	0,01	0,005
850	-0,05	1095	-0,063	80,5	±0,3	±0,12	43,5	±0,3	±0,03	0,012	0,006
950	-0,05	1200	-0,063	86	±0,3	±0,12	46	±0,3	±0,03	0,012	0,006
1030	-0,063	1300	-0,08	92,5	±0,3	±0,15	52,5	±0,3	±0,03	0,012	0,006

Bearing tolerances

# SIZE CHARTS

All ROTAB series bearings are exchangeable with the axial-radial bearings of established manufacturers. Therefore it is possible to choose a ROTAB-ARS (AR) for heavy milling or a ROTAB DBS for the highest rotational speeds within one bearing size. The modular structure of the KRW ROTAB series enables an effective reduction of design variety of rotary tables.

## ROTAB® AR/ARS

Code	Dimensions												Fixing hole		
													Inner ring		
	d	D	H	H <sub>1</sub>	H <sub>2</sub>	C	D <sub>1</sub> max.	D <sub>2</sub>	D <sub>3</sub>	J	J <sub>1</sub>	a	d <sub>1</sub>	d <sub>2</sub>	Quantity
	[mm]	[mm]	[mm]	[mm]	[mm]	[mm]	[mm]	[mm]	[mm]	[mm]	[mm]	[mm]	[mm]	[mm]	[-]
ROTAB AR 460	460	600	70	46	24	22	560	-	-	482	580	8,2	9,3	15	46
ROTAB AR 580	580	750	90	60	30	30	700	-	-	610	720	11	11,4	18	46
ROTAB AR 650	650	870	122	78	44	34	800	-	-	680	830	13	14	20	46
ROTAB AR 850	850	1095	124	80,5	43,5	37	1018	-	-	890	1055	17	18	26	58
ROTAB AR 950	950	1200	132	86	46	40	1130	-	-	990	1160	17	18	26	58
ROTAB AR 1030	1030	1300	145	92,5	52,5	40	1215	-	-	1075	1255	17	18	26	70
ROTAB ARS 460	460	600	70	46	24	22	560	-	-	482	580	8,2	9,3	15	46
ROTAB ARS 580	580	750	90	60	30	30	700	-	-	610	720	11	11,4	18	46
ROTAB ARS 650	650	870	122	78	44	34	800	-	-	680	830	13	14	20	46
ROTAB ARS 850	850	1095	124	80,5	43,5	37	1018	-	-	890	1055	17	18	26	58
ROTAB ARS 950	950	1200	132	86	46	40	1130	-	-	990	1160	17	18	26	58
ROTAB ARS 1030	1030	1300	145	92,5	52,5	40	1215	-	-	1075	1255	17	18	26	70

Our overview is a selection of our bearings based on common connection dimensions for axial/radial bearings. You are missing a size, need to reduce the installation space or a special adaptation?

**We manufacture your customized ROTAB bearing for you!**

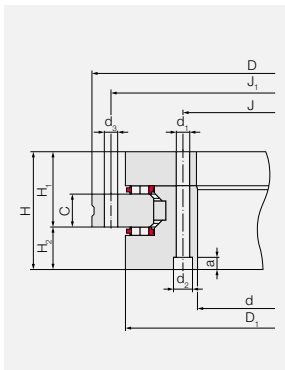

ROTAB® AR

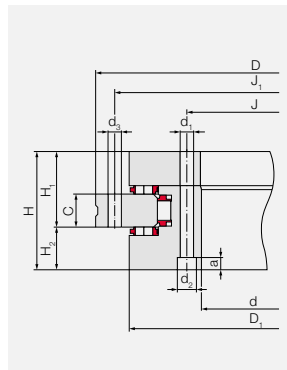

ROTAB® ARS

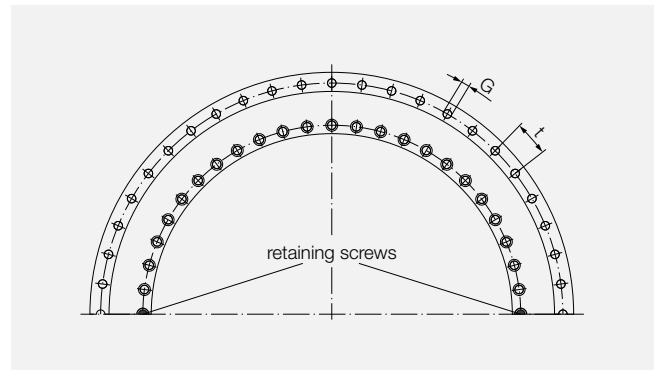

Outer ring		Pitch	Threaded extraction hole		Load ratings				Limiting speed	Rigidity of the roller set*			Mass
					axial		radial			axial rigidity	radial rigidity	tilting rigidity	
					dyn.	stat.	dyn.	stat.					
d <sub>3</sub>	Quantity	Quantity xt	G	Quantity	C <sub>a</sub>	C <sub>0a</sub>	C <sub>r</sub>	C <sub>0r</sub>	n <sub>G</sub>	c <sub>aL</sub>	a <sub>rL</sub>	c <sub>kL</sub>	≈
[mm]	[-]	[-]	[-]	[-]	[kN]	[kN]	[kN]	[kN]	[min <sup>-1</sup> ]	kN/μm	kN/μm	kN/mrad	kg
9,3	45	48 x 7,5°	M12	3	214	2070	229	980	95	34,7	19,7	992	45
11,4	42	48 x 7,5°	M12	6	387	4340	258	1230	75	57,7	24,5	2874	88
14	42	48 x 7,5°	M12	6	505	5850	570	2160	65	65,9	15,6	3680	169
18	54	60 x 6°	M12	6	575	7500	655	2820	50	84,0	20,6	7667	244
18	54	60 x 6°	M16	6	945	12100	690	3120	45	87,6	22,7	10138	309
18	66	72 x 5°	M16	6	985	13100	700	3380	40	94,3	24,4	12809	372
9,3	45	48 x 7,5°	M12	3	214	2070	147	545	300	34,7	10,6	992	44
11,4	42	48 x 7,5°	M12	6	387	4340	165	675	230	57,7	13,1	2459	87
14	42	48 x 7,5°	M12	6	505	5850	408	1390	200	65,9	8,8	3680	166
18	54	60 x 6°	M12	6	575	7500	453	1810	150	84,0	12,0	7666	241
18	54	60 x 6°	M16	6	945	12100	494	2010	130	87,6	13,1	10138	305
18	66	72 x 5°	M16	6	985	13100	520	2180	120	94,3	14,1	12809	367

\*The rigidity of a table bearing depends on many factors. The bearing is only one component in a complex suspension system. The values listed for bearing rigidity are calculated values in a relevant load range without regard for surrounding components. The listed rigidities serve primarily for comparison of different ROTAB bearings to dimension the rotary axle bearing.

For questions about the layout or technical details of our ROTAB series, please contact our KRW engineering team.

+49 341 45320-200

rotab@krw.de

# SIZE CHARTS

All ROTAB series bearings are exchangeable with the axial-radial bearings of established manufacturers. Therefore it is possible to choose a ROTAB-ARS (AR) for heavy milling or a ROTAB DBS for the highest rotational speeds within one bearing size. The modular structure of the KRW ROTAB series enables an effective reduction of design variety of rotary tables.

## ROTAB® DBS

Code	Dimensions												Fixing hole		
													Inner ring		
	d	D	H	H <sub>1</sub>	H <sub>2</sub>	C	D <sub>1</sub> max.	D <sub>2</sub>	D <sub>3</sub>	J	J <sub>1</sub>	a	d <sub>1</sub>	d <sub>2</sub>	Quantity
	[mm]	[mm]	[mm]	[mm]	[mm]	[mm]	[mm]	[mm]	[mm]	[mm]	[mm]	[mm]	[mm]	[mm]	[-]
ROTAB DBS 200	200	300	45	30	-	-	274	243	271	215	285	6,2	7	11	46
ROTAB DBS 260	260	385	55	36,5	-	-	345	313	348	280	365	8,2	9,3	15	34
ROTAB DBS 325	325	450	60	40	-	-	415	380	413	342	430	8,2	9,3	15	34
ROTAB DBS 395	395	525	65	42,5	-	-	486	450	488	415	505	8,2	9,3	15	46
ROTAB DBS 460	460	600	70	46	-	-	560	520	563	482	580	8,2	9,3	15	46
ROTAB DBS 580	580	750	90	60	-	-	700	660	700	610	720	11	11,4	18	46
ROTAB DBS 650	650	870	122	78	-	-	800	740	808	680	830	13	14	20	46
ROTAB DBS 850	850	1095	124	80,5	-	-	1018	958	1027	890	1055	17	18	26	58
ROTAB DBS 950	950	1200	132	86	-	-	1130	1060	1132	990	1160	17	18	26	58
ROTAB DBS 1030	1030	1300	145	92,5	-	-	1215	1143	1227	1075	1255	17	18	26	70

Our overview is a selection of our bearings based on common connection dimensions for axial/radial bearings. You are missing a size, need to reduce the installation space or a special adaptation?

**We manufacture your customized ROTAB bearing for you!**



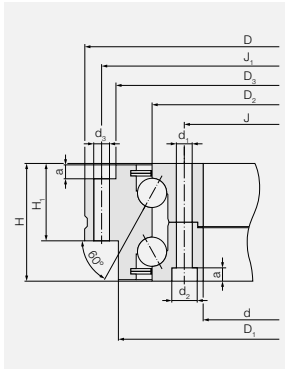

ROTAB® DBS (up to 460)

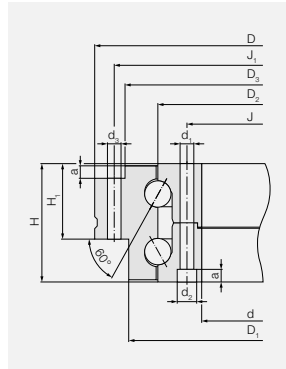

ROTAB® DBS (over 460)

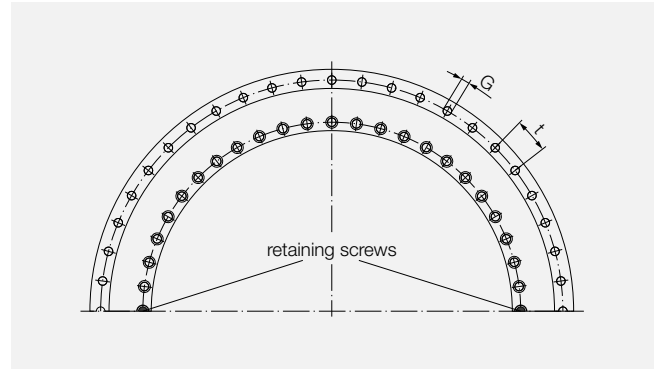

Outer ring		Pitch	Threaded extraction hole		Load ratings				Limiting speed	Rigidity of the roller set*			Mass
					axial		radial			axial rigidity	radial rigidity	tilting rigidity	
					dyn.	stat.	dyn.	stat.					
$d_3$	Quantity	Quantity xt	G	Quantity	$C_a$	$C_{0a}$	$C_r$	$C_{0r}$	$n_G$	$c_{aL}$	$a_{rL}$	$c_{kL}$	≈
[mm]	[-]	[-]	[-]	[-]	[kN]	[kN]	[kN]	[kN]	[min <sup>-1</sup> ]	[kN/μm]	[kN/μm]	[kN/mrad]	[kg]
7	45	48 x 7,5°	M8	3	124	620	-	-	3100	3,1	0,5	25	10
9,3	33	36 x 10°	M12	3	163	920	-	-	2300	4,4	0,7	59	19
9,3	33	36 x 10°	M12	3	174	1110	-	-	1900	5,2	0,9	103	25
9,3	45	48 x 7,5°	M12	3	245	1580	-	-	1500	5,5	0,9	151	33
9,3	45	48 x 7,5°	M12	3	264	1890	-	-	1300	6,5	1,1	236	46
11,4	42	48 x 7,5°	M12	6	354	2800	-	-	940	9,2	1,5	540	89
14	42	48 x 7,5°	M12	6	565	4330	-	-	810	11,0	1,8	821	174
18	54	60 x 6°	M12	6	645	5850	-	-	560	14,0	2,3	1724	248
18	54	60 x 6°	M16	6	765	7350	-	-	480	14,9	2,5	2249	292
18	66	72 x 5°	M16	6	795	8050	-	-	420	15,8	2,6	2775	378

\*The rigidity of a table bearing depends on many factors. The bearing is only one component in a complex suspension system. The values listed for bearing rigidity are calculated values in a relevant load range without regard for surrounding components. The listed rigidities serve primarily for comparison of different ROTAB bearings to dimension the rotary axle bearing.

For questions about the layout or technical details of our ROTAB series, please contact our KRW engineering team.

+49 341 45320-200

rotab@krw.de

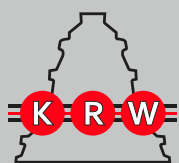

**KRW Leipzig GmbH**

Gutenbergstraße 6  
04178 Leipzig

Phone: +49 341 45320-200

Fax: +49 341 45320-201

E-Mail: [sales@krw.de](mailto:sales@krw.de)

[www.krw.de](http://www.krw.de)