

Rod Ends and Spherical Plain Bearings



FLURO®-Gelenklager GmbH

Introduction

Rod Ends and Spherical Plain Bearings are assembled machine parts to DIN ISO 12240 (former DIN 648), ready for installation. They are used to guarantee the unproblematic movement between shaft and housing, especially where the movement is not directly linear.

The **FLURO®** production program consists of Spherical Plain Bearings in all Series (DIN ISO 12240-1) and Rod Ends Series K and E (DIN ISO 12240-4), as well as Hydraulic Rod Ends with weld-on surface or female thread fixable with hexagon socket head cap screws. As new products in this catalogue are Thrust Bearings and Angular Contact Spherical Plain Bearings. To supplement the product range Angle Joints, Fork Heads, Locking Nuts and Rubber Seals have been added.

Where bearings with standard dimensions cannot be used, parts to customer designs are manufactured. Alternatively we can develop solutions for special applications. A small selection of these parts may be seen on the last pages of this catalogue. Our premium trained engineering and quality guarantee staff is pleased to offer advise on any application demand.

With high standard machinery we are able to turn, grind and mill parts with the highest precision. A list of our machining capabilities is available on request.

We have been approved for quality assurance to DIN EN ISO 9001 since June 1997.

Our sales staff is happy to assist you with any inquiry.

Just recently our industrial unit was enlarged and modernized. This meant advanced improvements to our logistics and an enlarged stock of products for faster delivery response.



Contents

General

| | |
|----------------------------------|----|
| Introduction | 2 |
| Contents | 3 |
| Contents | 4 |
| Production Program | 5 |
| FLUROGLIDE®/Motorsport | 12 |
| Ordering Details | 13 |

Technical Data

| | |
|--|----|
| Thread, Pivoting Angle | 14 |
| Fit, Installation | 15 |
| Internal Clearance | 16 |
| Lubrication, Temperature, Material | 17 |
| Technical Information | 18 |
| Calculation Examples | 22 |

Rod Ends Series K

| | |
|---|----|
| Standard GI/GA | 24 |
| Heavy Duty GIS/GAS | 26 |
| Extra Heavy Duty GIXS/GAXS | 28 |
| Heavy Duty Stainless Steel GIRS/GARS | 30 |
| Stainless Steel GIRS..R/GARS..R | 32 |
| Heavy Duty Maintenance Free GISW/GASW | 34 |
| ditto Extra Heavy Duty GIXSW/GAXSW | 36 |
| Heavy Duty Stainless Steel GIRSW/GARSW | 38 |
| Stainless Steel GIRSW..R/GARSW..R | 40 |
| ditto GIRSW..RR/GARSW..RR | 42 |
| ditto GIRSW..RR.316/GARSW..RR.316 | 44 |
| Stainless Steel GIRSW..NIRO/GARSW..NIRO | 46 |
| Steel on Steel GIO/GAO | 48 |
| Steel/PTFE GIOW/GAOW | 50 |
| Rod Ends with Seals | 52 |
| ditto with Threaded Bolt | 53 |
| ditto for Pneumatic Cylinders | 54 |

Spherical Plain Bearings Series K

| | |
|--------------------------------------|----|
| Standard GL | 55 |
| Heavy Duty GLXS | 56 |
| ditto Stainless Steel GLRS | 57 |

| | |
|--|----|
| ditto Stainless Steel GLRS..R | 58 |
| Maintenance Free GLXSW | 59 |
| ditto Stainless Steel GLRSW | 60 |
| Stainless Steel GLRSW..R | 61 |
| ditto GLRSW..RR | 62 |
| ditto GLRSW..RR.316 | 63 |
| Heavy Duty GXS | 64 |
| ditto for Stainless Steel GXS..R | 65 |
| Maintenance Free GXSW | 66 |
| ditto Stainless Steel GXSW..R | 67 |
| ditto Stainless Steel GXSW..RR | 68 |
| ditto Stainless Steel GXSW..RR.316 | 69 |

Rod Ends Series E

| | |
|---|----|
| Steel on Steel EI(-2RS) / EA 50(-2RS) | 72 |
| Maintenance Free | |
| EI..D(-2RS)/EA..D(2RS) | 74 |
| ditto Stainless Steel | |
| EI..D-NIRO(-2RS)/EA..D-NIRO(-2RS) | 76 |

Spherical Plain Bearings Series E

| | |
|---|----|
| Maintenance Free GE...EC (2RS) | 70 |
| ditto Stainless Steel GE...EC-NIRO (-2RS) | 71 |
| Steel on Steel GE...E (-2RS) | 78 |
| Steel on Steel GE...HO-2RS | 79 |
| Inch-sized version GE..ZO (-2RS) | 80 |

Spherical Plain Bearings Series W

| | |
|----------------------------------|----|
| Steel on Steel GE...LO | 82 |
|----------------------------------|----|

Spherical Plain Bearings Series G

| | |
|--|----|
| Steel on Steel GE...FO (-2RS) | 83 |
| Maintenance Free GE...FW (-2RS) | 84 |
| ditto Stainless Steel GE..FW-NIRO (-2RS) | 85 |

Angular Contact Spherical Plain Bearings

| | |
|------------------------------------|----|
| Steel on Steel GE...SX | 86 |
| Maintenance Free GE...SW | 87 |

Contents

Spherical Plain Thrust Bearings

| | |
|------------------------------------|----|
| Steel on Steel GE...AX | 88 |
| Maintenance Free GE...AW | 89 |

Rod Ends - Hydraulic

| | |
|--|----|
| with Locking Device FPR...S | 90 |
| ditto for Pneumatic Cylinder FPR...CE | 91 |
| short thread FPR...N | 92 |
| ditto with Locking Device FPR...U | 93 |
| Heavy Duty with Locking Device FMA...D | 94 |
| with Weld-on Surface FS...C | 95 |
| with Weld-on Surface FS...N | 96 |

Angle Joints

| | |
|-------------------------------------|----|
| Angle Joints to DIN 71802 | 97 |
|-------------------------------------|----|

Fork Heads

| | |
|---|----|
| Fork Heads to DIN 71751 and DIN 71752 | 98 |
|---|----|

Rubber Seals

| | |
|-------------------------------------|----|
| Rubber Protector Cap RERS | 99 |
| Washer Seals RELS | 99 |

Locking Nuts

| | |
|--|-----|
| Locking Nuts to DIN 934 / ISO 4032 | 100 |
| Locking Nuts to DIN 439 / 936 | 100 |

Cylindrical Bearings

| | |
|----------------------------|-----|
| Description | 101 |
| Series BK1.. | 102 |
| Series BK1..BU | 104 |
| Thrust washer DU | 105 |

Bearing block for Hydraulic Cylinders

| | |
|---|-----|
| Series IKA | 106 |
| Series IKB | 107 |
| Series DK | 108 |
| Bolt for Bearing Block KPA.. / KPB.. | 109 |
| Bolt for bearing block KE.. / KPC.. / KPD.. | 110 |
| Fixing plate for bearing block PPP | 111 |
| Fork head for bearing block IF.. | 112 |
| Connecting pin PB.. | 113 |
| Bracket IS../ISS.. | 114 |

Specials

| | |
|--|-----|
| Precision Parts Martin Höhn GmbH | 115 |
| Inquiry Template Special Parts | 116 |
| Notes | 117 |
| Notes | 118 |
| Specialties | 119 |

| | |
|-------------------------------|----|
| How you can find us | U4 |
|-------------------------------|----|



Catalogue, Edition 2018

Every care has been taken to ensure the accuracy of the information in this catalogue. However, no liability can be accepted for any errors or omissions. Due to continuing technical advances, we reserve the right to alter our products without notice. Our sales and delivery terms and conditions in the respective valid version, shall apply exclusively for deliveries and other services in commercial business transactions.

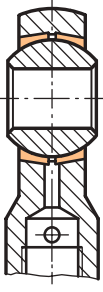
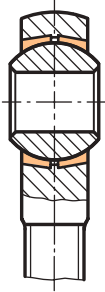
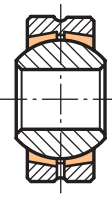
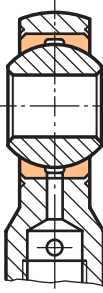
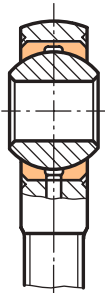
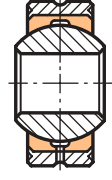
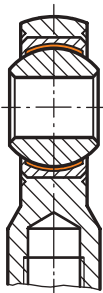
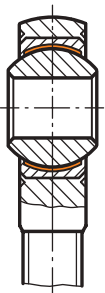
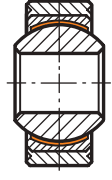
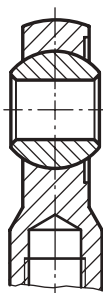
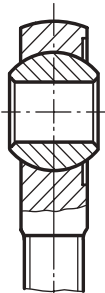
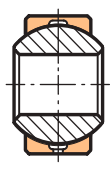
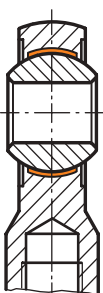
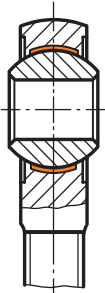
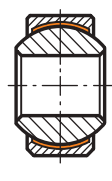

Production Range Series K

| Rod Ends DIN ISO 12240-4 Series K Female Thread | | | Rod Ends DIN ISO 12240-4 Series K Male Thread | | | Spherical Plain Bearings DIN ISO 12240-1 Series K with / without outer ring | | |
|---|---|---|---|---|---|---|---|---|
| GI.. | Requiring maintenance |  | GA.. | Requiring maintenance |  | GL.. | Requiring maintenance |  |
| GIS.. GIXS.. GIRS.. GIRS..R | Heavy Duty, Requiring maintenance |  | GAS.. GAXS.. GARS.. GARS..R | Heavy Duty, Requiring maintenance |  | GLXS.. GLRS.. GLRS..R | Standard-/ Stainless Steel, Maintenance free |  |
| GISW.. GIXSW.. GIRSW.. GIRSW..R GIRSW..RR GIRSW..RR.316 GIRSW..NIRO | Standard-/ Stainless Steel, Maintenance free |  | GASW.. GAXSW.. GARSW.. GARSW..R GARSW..RR GARSW..RR.316 GARSW..NIRO | Standard-/ Stainless Steel, Maintenance free |  | GLXSW.. GLRSW.. GLRSW..R GLRSW..RR GLRSW..RR.316 | Standard-/ Stainless Steel, Maintenance free |  |
| GIO.. | Steel on Steel |  | GAO.. | Steel on Steel |  | GXS.. GXS..R | Standard-/ Stainless Steel, Maintenance free |  |
| GIOW.. | Maintenance free |  | GAOW.. | Maintenance free |  | GXSW.. GXSW..R GXSW..RR GXSW..RR.316 | Standard-/ Stainless Steel, Maintenance free |  |



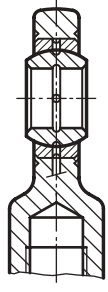
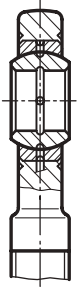
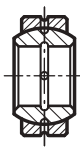
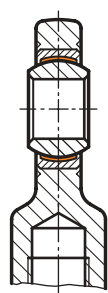
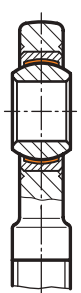
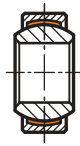
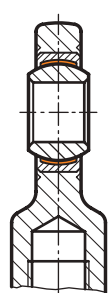
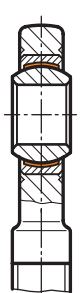
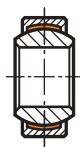

Production Range Series E

| Rod Ends DIN ISO 12240-4 Series E Female Thread | | Rod Ends DIN ISO 12240-4 Series E Male Thread | | Spherical Plain Bearings DIN ISO 12240-1 Series E | | | | |
|--|------------------|---|------------------------------|--|---|--|------------------|---|
| EI.. EI..-2RS | Steel on Steel |  | EA.. EA..-2RS | Steel on Steel |  | GE..E GE..E-2RS GE..ZO GE..ZO-2RS | Steel on Steel |  |
| EI..D EI..D-2RS | Maintenance free |  | EA..D EA..D-2RS | Maintenance free |  | GE..EC GE..EC-2RS | Maintenance free |  |
| EI..D-NIRO EI..D-NIRO-2RS | Stainless Steel |  | EA..D-NIRO EA..D-NIRO-2RS | Stainless Steel |  | GE..EC-NIRO GE..EC-NIRO-2RS | Stainless Steel |  |



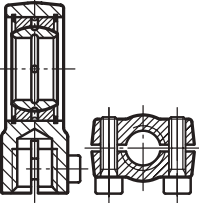
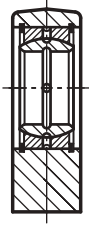
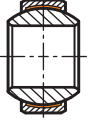
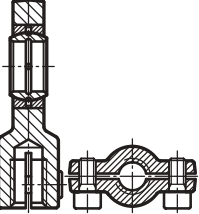
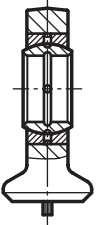
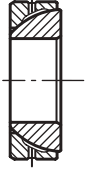
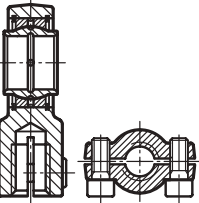
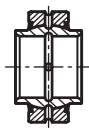

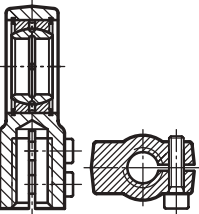
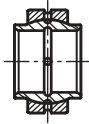
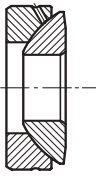
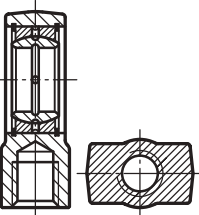
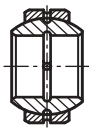
Eccentric Rod End with self-aligning roller bearing

Production Range

| Hydraulic Rod Ends Steel on Steel | | Hydraulic Rod Ends + Spherical Plain Bearings Steel on Steel | | Spherical Plain Bearings | | | | |
|--------------------------------------|---|---|---------------|--|---|--|--|---|
| FPR..U | Rod End with Locking Device Bearing with Snap Ring |  | FS..N | Rectangular Weld-on Surface Bearing with Snap Ring |  | GE..FW (-2RS) GE..FW-NIRO (-2RS) | Maintenance free, Heavy Duty, higher Pivoting Angle |  |
| FPR..S | Rod End with Locking Device Bearing fixed through caulking |  | FS..C | Circular Weld-on Surface Bearing fixed through caulking |  | GE..SX | Steel on Steel Angular Contact Bearing |  |
| FPR..CE | Rod End with Locking Device Bearing with Snap Ring |  | GE..HO-2RS | Steel on Steel Ball with Shoulder |  | GE..SW | Maintenance free Angular Contact Bearing |  |
| FMA..D | Rod End with Locking Device Bearing with Snap Ring |  | GE..LO | Steel on Steel Ball with Shoulder |  | GE..AX | Steel on Steel Thrust Bearing |  |
| FPR..N | Rod End with shorter thread Bearing with Snap Ring |  | GE..FO (-2RS) | Steel on Steel, Heavy Duty, higher Pivoting angle |  | GX..AW | Maintenance free Thrust Bearing |  |

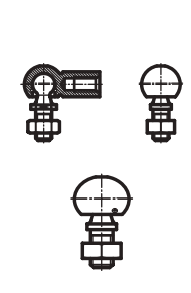
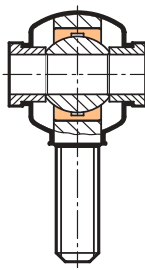
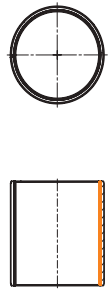
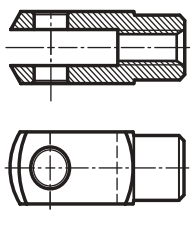
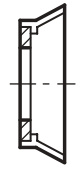
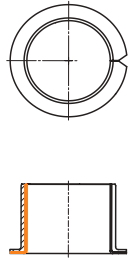
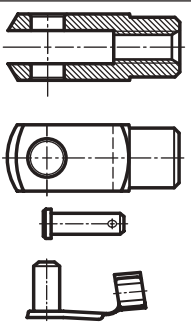
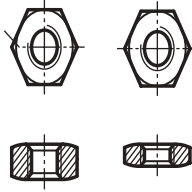
Production Range

| Angle Joints to DIN 71802 Fork Head to DIN 71752 | | | Rubber Seals Locking Nuts to DIN 934 / 439 | | | Cylindrical bearings | | |
|---|---------------------------|---|---|--|--|----------------------|--|---|
| Form C../CS.. | Angle Joints to DIN 71802 |  | RERS | Rubber Protector Caps made from Neoprene |  | BK1.. | Cylindrical plain bushing |  |
| G..x.. | Fork Head to DIN 71752 |  | RELS | Washer Seals Rubber Seals with stainless steel washer rings |  | BK1..BU | Cylindrical plain bushing with collar |  |
| with ES-Bolt clevis spring pin | Fork Head to DIN 71751 |  | KMR.. KML.. | Locking Nuts with right hand or left hand threads |  | Washer DU | Thrust washer |  |



Angle Joints

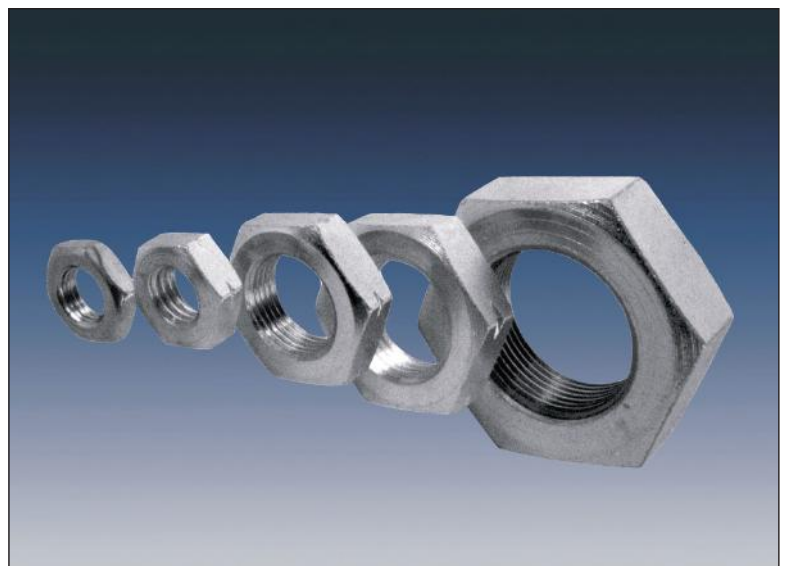

Locking Nuts / Jam nuts

Production Range

| Bearing block Bracket | | Bearing block Fork head | | Connecting bolt Fixing plate | |
|--------------------------|---------------------------|----------------------------|------------------------|---------------------------------|--------------------------------|
| IKA.. | Fork bearing block form A | IS.. ISS.. | Trunning bearing block | KPA.. KPB.. | Connecting bolt |
| IKB.. | Fork bearing block form B | IF.. | Fork head | KPC.. KPD.. KPE.. | Connecting bolt regreasable |
| DK.. | Oscillating bearing block | PB.. | Connecting pin | PPP.. | Fixing plate |



Hydraulic Rod Ends

Special Applications



railway vehicles



conveyors



loading cranes



construction machinery



scissors lift



shipbuilding

Custom made products

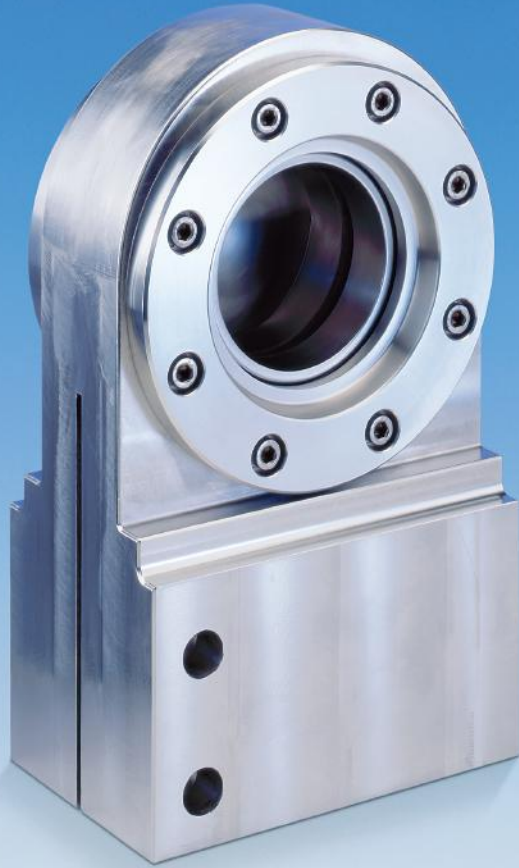

Hydraulic Rod Ends designed and intended for marine, harbor and river engineering or lock gates. Completely stainless steel to customer design with maintenance free or regreasable Spherical Plain Bearing. Design and development according to customer requirements.



Connecting rod for highest pressure and tension loads, employed in automotive applications. These parts are supplied completely mounted with required axial distance and torque.

FLURO® Motor Sport Series

FLURO® has developed a series of Rod Ends and Spherical Plain Bearings, which have zero tolerance through preloaded bearing, for Motor Sport applications.

**Exclusive
Motor Sport Catalogue
on request !**

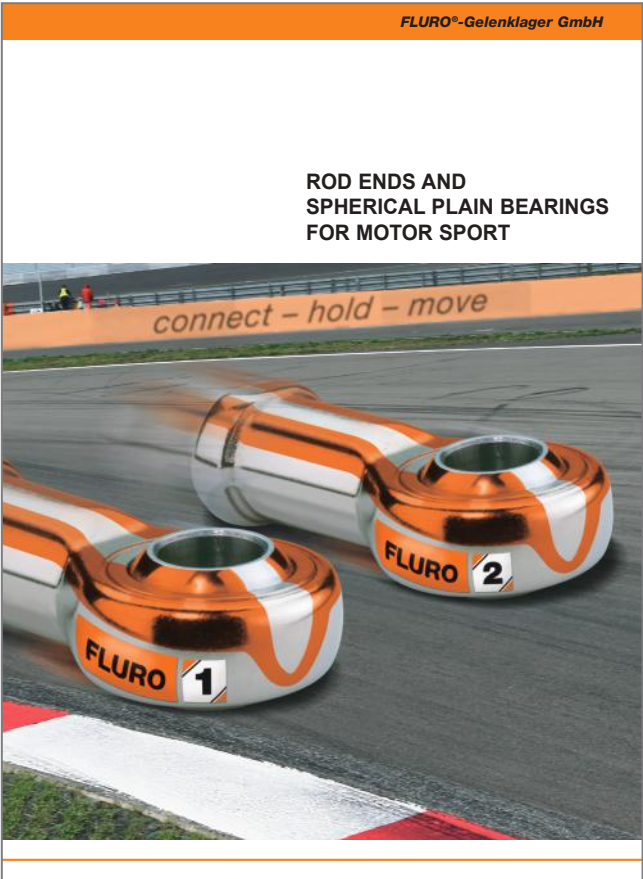

For Rod Ends and Spherical Plain Bearings for extreme demands the latest development **FLUROGLIDE®**, a special developed coating, which is used for Rod Ends and Spherical Plain Bearings with highest demands, provides a solution.

**Please ask for our
exclusive
FLUROGLIDE® catalogue**

Ordering Details

On pages 5 to 10 we have given full details of our standard range of products. Additional notes to make sure details are correct when placing orders are listed below; additions to and deviations from our standard program are listed, as well.

| | |
|---|--|
| Female Thread: | The letter I is situated in the second place in the reference e.g. GI or EI |
| Male Thread: | The letter A is situated in the second place in the reference e.g. GA or EA |
| Left Hand Thread: | The letter L is situated in the third place in the reference e.g. GAL or EAL |
| Non-Standard Thread: | Bearing reference with additional thread specification e.g. GISW 30, M 27x2 |
| Stainless Steel Ball: | The letter R will be added after size reference e.g. GIRSW 10 R , GXSW 10 R , stainless version (stainless type see pages 32, 40, 58, 61, 65, 67) |
| Completely Stainless (Series K): | The letters RR will be added after size reference e.g. GARSW 16 RR , GXSW 16 RR (all items in stainless steel) |
| Completely Stainless (Series E): | The letters NIRO will be added after size reference e.g. GE 10 EC- NIRO or EI 16 D- NIRO |
| Ball Hard Chrome Plated: | ICR will be added after size reference e.g. GASW 10 ICR |
| Seal: | -2RS will be added after size reference e.g. GISW 10- 2RS (see pages 52) |
| Threaded Bolt: | BO will be added after size reference e.g. GISW 10 BO (for right angle use, see page 53) |
| Nickel Plated Housing: | NI will be added after size reference e.g. GISW 14 NI (improved corrosion resistance for the housing) for series on pages 26 to 29, 34 to 37 |
| Special Grease Nipples: | SN will be added after size reference e.g. GAS 16 SN DIN 71412 H1/A M6x1 (exact name of grease nipple has to be specified) |
| Left Hand Thread for Hydraulic Rod Ends: | The letter L will be added at the third place replacing the letter R e.g. FPL...N , except for series FMA...D = FMAL...D |

For sizes deviating from the standard or for specials, please send us your drawing or sketch – see template on page 116.

The maintenance instructions, selection criteria, tolerances and calculations as shown in the following technical section are intended to be an important guideline for the choice of the correct bearing to suit the particular application of our Rod Ends and Spherical Plain Bearings.

Thread, Pivoting Angle

Threads

Manufactured to standard metric ISO DIN 13 threads. To increase the stability for all standard Rod Ends with male threads, the threads are rolled.

Because of the process procedure of zinc plating, it can not be guaranteed that the zinc layer will reach completely into the thread bore of the female rod ends with its complete zinc layer thickness.

Maximum Pivoting Angle

The permissible maximum Pivoting Angle (see picture 3, page 19) ranges between 6° and 35° depending on the series and constructional design.

The Maximum Pivoting Angle you will find in the product data sheets of series K and series E. The indicated Maximum Pivoting Angles are guide values related to situation 2. Other constructional designs and its calculation examples for the Maximum Pivoting Angle α are indicated in situations 1 and 3.

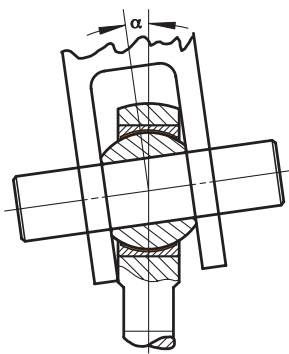

Situation 1

$$\alpha = \sin^{-1} \frac{B}{A} - \sin^{-1} \frac{M}{A}$$

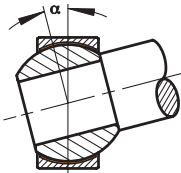

Situation 2

$$\alpha = \sin^{-1} \frac{B}{dK} - \sin^{-1} \frac{M}{dK}$$

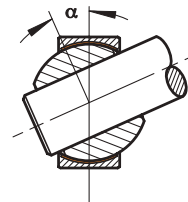

Situation 3

$$\alpha = \cos^{-1} \frac{D}{dK} - \sin^{-1} \frac{M}{dK}$$

A = Outside diameter Rod End/Spherical Plain Bearing

B = Width Ball

dK = diameter Ball

M = Width Rod End/Spherical Plain Bearing

D = diameter Bore Ball

Fit, Installation

Recommended fits for the housing's bore to incorporate Spherical Plain Bearings

| | | Design | Steel Housing Series K | Light Alloy Housing Series K | Steel Series E / G / W | Light Alloy Housing Series E / G / W |
|------|--------|------------------|------------------------|------------------------------|------------------------|--------------------------------------|
| Load | normal | maintenance free | K7 | M7 | K7 | M7 |
| | | regreasable | J7/H7 | K7 | K7 | M7 |
| | high | maintenance free | M7 | N7 | M7 | N7 |
| | | regreasable | K7 | M7 | M7 | N7 |

The outside diameter of the Spherical Plain Bearings, Series K is tolerated to h6. For Series E, please refer to each individual product page.

Recommended fit for the shaft

| | | Design | Series K | Series E GE..E (-2RS) GE..EC (-2RS) GE..EC-Niro GE..HO-2RS | Series G GE..FO (-2RS) GE..FW (-2RS) | Series W GE..LO |
|------|--------|--------|----------|--|--|--------------------|
| Load | normal | | h6 | g6 | g6 | h6 |
| | high | | k6 | j6/h6 | j6/h6 | j6 |

Installation instructions:

Attention: No tolerance or play can be allowed for the shaft when incorporated in the Ball or the Outer Ring when incorporated in a housing. Through this it is guaranteed that the glide movement arises on the nodular gliding surface only.

When mounting extra precaution has to be taken that the press force does not damage the bearing. The press force should not be initiated via the Ball itself. Through cooling of the bearing and heating of the housing the necessary press force will be reduced.

Axial locking of Spherical Plain Bearings:

When under high static or dynamic axial load, vibration, impacting load changes or high pivoting angles Spherical Plain Bearings have to be locked axially.

Possible locking methods:

- locking through several puncher points
- caulking of bearing on the housing through a flanging groove
- with locking snap rings
- clamped with bushings on the facing surface of the Insert

Internal Clearance

Internal Clearance is defined as the measure, which can be moved of the radial movement of the ball in the housing or outer ring from a limit position to the opposing. Internal Clearance is measured at room temperature. The axial freedom of movement corresponds approximately to coefficient 3 of the internal clearance.

| Series K Type | Size | Radial Internal Clearance in mm (min./max.) |
|---|---|---|
| GI/GA; GIS/GAS; GIXS/GAXS; GIRS/GARS (..R) | 02 - 10 12 - 20 22 - 40 | 0,005 - 0,035 0,010 - 0,040 0,010 - 0,050 |
| GISW/GASW; GIXSW/GAXSW; GIRSW/GARSW (..R / ..RR / ..RR.316 / NIRO) | 05 - 10 12 - 18 20 - 25 30 - 40 | 0,005 - 0,030 0,005 - 0,035 0,005 - 0,045 0,005 - 0,055 |
| GLOW/GAOW | 04 - 10 12 - 20 | 0,005 - 0,040 0,005 - 0,050 |
| GIO/GAO | 05 - 10 12 - 20 | 0,010 - 0,050 0,010 - 0,060 |
| GL; GLXS; GLRS (..R); GXS (..R) | 02 - 10 12 - 18 20 - 25 30 - 40 40 - 50 | 0,005 - 0,040 0,005 - 0,050 0,010 - 0,060 0,010 - 0,075 0,015 - 0,095 |
| GLXSW; GXSW (..R / ..RR / ..RR.316) GLRSW (..R / ..RR / ..RR.316) | 03 - 10 12 - 18 20 - 25 30 - 40 40 - 50 | 0,005 - 0,035 0,005 - 0,040 0,005 - 0,050 0,010 - 0,060 0,010 - 0,075 |

| Series E Type | Size | Radial Internal Clearance in mm (min./max.) |
|---|---|---|
| EI/EA | 06 - 12 15 - 20 25 - 35 40 - 60 70 - 80 | 0,015 - 0,050 0,020 - 0,065 0,030 - 0,085 0,035 - 0,100 0,045 - 0,120 |
| EI..D/EA..D (-2RS) EI..D-NIRO (-2RS) EA..D-NIRO (-2RS) | 06 - 12 15 - 20 25 - 35 40 - 60 70 - 80 | 0,000 - 0,030 0,000 - 0,040 0,000 - 0,050 0,000 - 0,055 0,000 - 0,060 |
| GE...EC-NIRO (-2RS) | 06 - 12 15 - 20 25 - 35 40 - 60 70 - 90 100 - 120 140 - 160 | 0,000 - 0,032 0,000 - 0,040 0,000 - 0,050 0,000 - 0,060 0,000 - 0,072 0,000 - 0,085 0,000 - 0,100 |

| Series E, G, W Type | Size | Radial Internal Clearance in mm (min./max.) |
|--|---|---|
| GE...E (-2RS) GE...HO-2RS GE...LO | 04 - 12 15 - 20 25 - 35 40 - 60 70 - 90 100 - 140 160 - 240 260 - 300 320 - 320 | 0,032 - 0,068 0,040 - 0,082 0,050 - 0,100 0,060 - 0,120 0,072 - 0,142 0,085 - 0,165 0,100 - 0,192 0,110 - 0,214 0,135 - 0,261 |
| GE...EC (-2RS) | 04 - 20 25 - 35 40 - 60 70 - 90 100 - 140 160 - 180 200 - 300 | 0,000 - 0,040 0,000 - 0,050 0,000 - 0,060 0,000 - 0,072 0,050 - 0,130 0,050 - 0,140 0,080 - 0,190 |
| GE...FO (-2RS) | 04 - 10 12 - 17 20 - 30 35 - 50 60 - 80 90 - 120 140 - 160 180 - 220 240 - 280 | 0,032 - 0,068 0,040 - 0,082 0,050 - 0,100 0,060 - 0,120 0,072 - 0,142 0,085 - 0,165 0,100 - 0,192 0,100 - 0,192 0,110 - 0,214 |
| GE...FW (-2RS) GE..FW-NIRO (-2RS) | 04 - 30 35 - 50 60 - 80 90 - 120 140 - 160 260 - 280 | 0,000 - 0,050 0,000 - 0,060 0,000 - 0,072 0,050 - 0,130 0,050 - 0,140 0,080 - 0,190 |

| Series Hydraulic | Size | Radial Internal Clearance in mm (min./max.) |
|---|---|---|
| FPR...S FPR...CE FPR...N FPR...U FMA...D FS...C FS...N | 10 - 12 15 - 20 25 - 35 40 - 60 63 - 90 100 - 125 160 - 200 | 0,023 - 0,068 0,030 - 0,082 0,037 - 0,100 0,043 - 0,120 0,055 - 0,142 0,065 - 0,165 0,065 - 0,192 |

For special applications Rod Ends and Spherical Plain Bearings are manufactured with smaller or higher internal clearance. **C2** is smaller (tighter fit) than given above and **C3** is higher (increased internal clearance) than given above, available on request. (bitte prüfen ... **C1 / C0**)

Lubrication

Maintenance Free Rod Ends and Spherical Plain Bearings must not be lubricated. The ball revolves on a PTFE liner incorporated in the housing.

Rod Ends with Steel running on special Brass, or with Steel running on Bronze, and Steel on Steel require regular lubrication. The first time lubrication has to be carried out when the part is mounted. The regreasing interval depends on the impacting influences, such as ambient conditions (temperature, dust, etc) and the mechanical impacts given through the application (surface pressure, number of alternation stress, pivoting angle, gliding speed, etc.).

For the lubrication of Spherical Plain Bearings up to a temperature of +110° Celsius, (+230° Fahrenheit) white paste, such as Gleitmo 805k, is recommended. For higher temperatures from +110° to +220° Celsius, (+230° to +428° Fahrenheit) we recommend high temperature grease, such as Notropeen EHT2.

Regreaseable Rod Ends Series K are lubricated by means of a grease nipple to DIN 3405.

For Steel on Steel Rod Ends Series E from size 20 hydraulic grease nipples to DIN 71412 are incorporated.

Temperature range

FLURO® Rod Ends and Spherical Plain Bearings can be operated within the operating temperatures listed below:

| Mating surface | Temperature Celsius | Temperature Fahrenheit |
|------------------------------|---------------------|------------------------|
| Steel/Special Brass | – 50° to +200° | – 58° to +392° |
| Steel/Bronze | – 50° to +250° | – 58° to +480° |
| Steel/PTFE liner | –150° to +250° | –238° to +480° |
| Steel/PTFE Glass fibre liner | – 75° to +150° | –103° to +302° |
| Steel/Steel | – 50° to +200° | –103° to +392° |
| GE...EC, FW, AW, SW | – 50° to +150° | – 58° to +302° |
| GE...-2RS | – 30° to +130° | – 22° to +266° |
| GE...EC-NIRO | –150° to +250° | –238° to +480° |
| PTFE/hard chrome | – 50° to +150° | – 58° to +302° |

From a temperature range from above +250° C our heavy duty Spherical Plain Bearings are used.

Material Conversion Table

| Material | DIN German | France | Italy | Sweden | UK | USA |
|----------|-------------------|---------------|----------------|--------|--------|------------------|
| 1.0402 | C22 | XC25 | C21 | 1450 | 070M20 | M1023 |
| 1.0503 | C45 | 1C45 | C45 | 1650 | 080M46 | Aisi 1045 |
| 2.1030 | CuSn8 | | | | | |
| 2.0561 | CuZn40Al1 | | | | | |
| 1.3505 | 100Cr6 | 100Cr6 | 100Cr6 | 2258 | 2S135 | Aisi 52100 |
| 1.7225 | 42CrMo4 | 42CrMo4 | 42CrMo4 | 2244 | 708M40 | Aisi 4140 |
| 1.0718 | 9SMnPb28K | S250Pb | CF9SMnPb28 | 1912 | 230M07 | 12L13 |
| 1.4006 | X10Cr13 | Z10C13 | X12Cn13 | 2302 | 410C21 | Aisi 410 |
| 1.4034 | X46Cr13 | Z44C14 | X40Cr14 | | 420S45 | Aisi 420C |
| 1.4057 | X20CrNi172 | Z15CN16-02 | X16CrNi16 | 2321 | 431S29 | Aisi 431 |
| 1.4112 | X90CrMoV18 | | | | | Aisi 440B |
| 1.4125 | X105CrMo17 | Z100CD17 | | | | Aisi 440C |
| 1.4301 | X5CrNi1810 | Z4CN19-10FF | X5CrNi1810 | 2332 | 304S17 | Aisi 304 |
| 1.4305 | X10CrNiS189 | Z8CNF18-09 | X10CrNiS1809 | 2346 | 303S22 | Aisi 303 |
| 1.4401 | X5CrNiMo17122 | Z7CND17-12-02 | X5CrNiMo1712 | 2347 | 316S17 | Aisi 316 |
| 1.4542 | X5CrNiCuNb174 | Z7CNU15-05 | ————— | ————— | ————— | Aisi 630 (174Ph) |
| 1.4571 | X6CrNiMoTi17-12-2 | Z6CNDT17-12 | X6CrNiMoTi1712 | 2350 | 320S18 | Aisi 316Ti |

Bearing Load ratings

Bearing Load ratings are bearing specific data, derived from the characteristics of the materials used. They are used when selecting Spherical Plain Bearings or Rod Ends for a particular load, but may have to be reduced in adverse operating conditions.

Static Load ratings C_o [kN]

C_o indicates the maximum permissible static load which a Rod End at its weakest cross section can withstand without developing permanent distortion. The C_o values listed in the tables of this brochure have been calculated by using the appropriate material specifications and have been tested on a number of Rod Ends during tensile tests carried out at ambient temperature. 80% of the yield strength resulting from the tests have been used so that a safety factor of 1.25 is included. The static load C_o is also used for establishing the maximum axial load which is limited by an additional bending stress principally due to the method of fastening of the insert. Following are maximum axial values (deformation) which have been established by pressure testing:

$$(1) \quad F_a = F_{a, \max} = a \cdot C_o \quad [\text{kN}]$$

- $a \approx 0,4$ for GI/GA + GIO/GAO + GXO
- $a \approx 0,2$ for GXSW, GXS, GL mounted in a FLURO® rod end housing
- $a \approx 0,1$ for EI/EA, EI/EA...D-NIRO

For Spherical Plain Bearings C_o indicates the radial load, which does not deform the mating surface permanently. Precondition is the stable configuration of the housing.

Dynamic Load ratings C [kN]

This rating is used to establish the working life of Spherical Plain Bearings or Rod Ends when under dynamic load conditions. That is to say when they oscillate, rotate or pivot under load. The values listed in the table result from multiplying the maximum surface pressure p_{\max} admissible in gliding movements by the projected bearing surface. A_{proj} , whereby a specific load rating is established for each type of Rod End. The established standard values for maximum surface load for various combinations of antio friction material have been listed in table 1 which allows for movement when oscillation. Information: Depending on the material strength of the Rod End housing (eg. pages 34 and 35) the static load might be lower than the dynamic load. For this the procedure stated on page 23 has to be observed.

For applications with threshold or/and alternating loads, the dynamic load rating of the rod end housing needs to be considered separately.

| p_{\max} [N/mm ²] | St/Ms | St/Bz | St/St soft | St/St hard | St/TBz | St/TNy |
|------------------------------------|-------|-------|---------------|---------------|--------|--------|
| | 50 | 50 | 50 | 100 | 150 | 50 |

Table 1: Maximum surface pressure

Abbreviations: St = Steel, Ms = Brass, Bz = Bronze, TBz = Woven Bronze Fabric, TNy = Woven Nylon

Forces affecting a Bearing

The loads affecting a Spherical Plain Bearing can vary. They can be:

- intermittent, constant or variable (illustration 1)
- static or dynamic

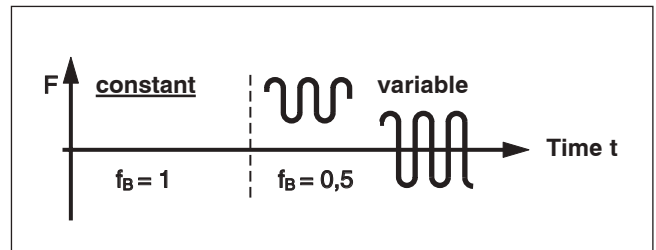

Picture 1: Load factors - check f_B

Attention: For Rod Ends with male thread factors choose $f_B = 0,35$ when load changeable.

Forces when under static load

Radial only (F_r) or radial and axial (F_a) forces arise and there is no movement between the ball and the insert (Picture 2).

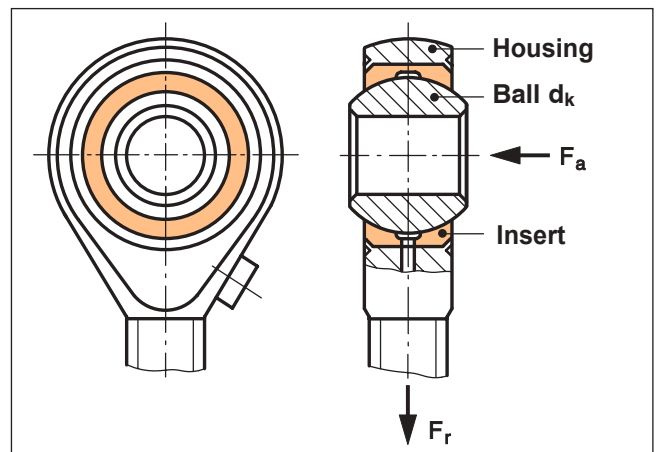

Picture 2: Radial and axial forces

Forces when under dynamic load

Radial or radial and axial forces arise, when the Ball pivots at angle α , oscillates at angle β or rotates relative to the Insert.

Technical Information

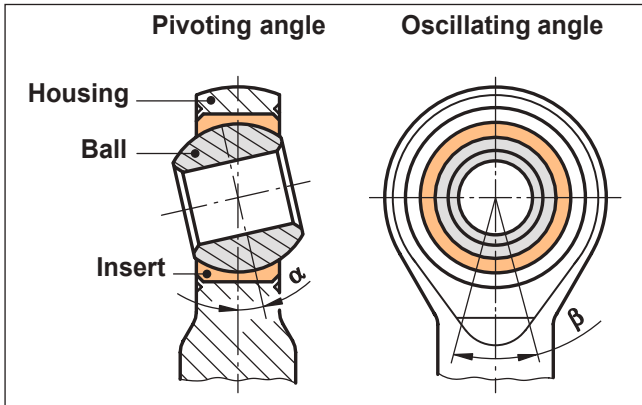

Picture 3: Pivoting and oscillating angle

In the case of a **constant load** F_r , F_a a dynamically equivalent bearing load F_e can be established in accordance with formula (2).

$$(2) \quad F_e = F_r + Y \cdot F_a \quad [\text{kN}]$$

therefore: $F_e \leq F_{r, \max}$ according to formula (6);
 $F_a \leq F_{a, \max}$ (6a)

The axial factor Y in table 2 is dependent on the load ratio.

| | | | | | |
|------------------------|-----|-----|-----|-----|-----|
| Load ratio $F_a : F_r$ | 0,1 | 0,2 | 0,3 | 0,4 | 0,5 |
| Axial factor Y | 0,8 | 1 | 1,5 | 2,5 | 3 |

Table 2: Axial factor Y

In the case of a **variable load** (picture 4), formula (4) can be used to calculate a mean dynamic bearing load F_m from the individual load levels F_i and the appropriate time factor t_i .

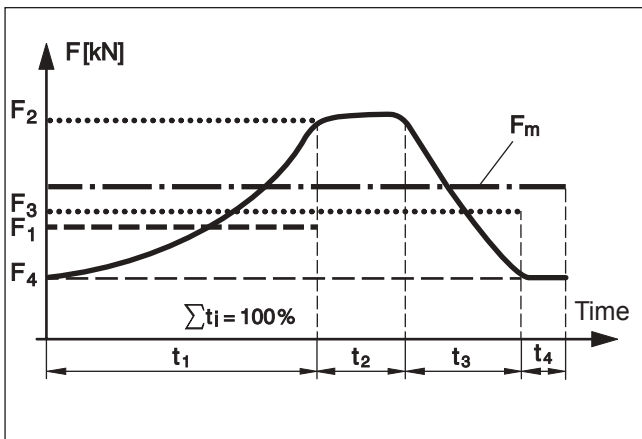

Picture 4: Variable load against time

$$(3) \quad F_m = 0,1 \sqrt{F_1^2 \cdot t_1 + F_2^2 \cdot t_2 + \dots} \quad [\text{kN}]$$

Force F [kN] : time component t [%]

therefore the following must be valid: $F_{i, \max} \leq F_{r, \max}$ according to (6)

In case of an additional axial load the equivalent bearing load is calculated according to formula (4).

$$(4) \quad F_e = F_m + Y \cdot F_a \quad [\text{kN}]$$

Axial factor Y according to table 2

$F_a \leq F_{a, \max}$ according to (6a)

Selection of the bearing size

The selection is usually made step by step, repeated if necessary, by comparing -

1. the load ratio involved with the normal minimum values for that ratio;
2. the forces affecting the bearing and the maximum permitted load of the bearing proposed;
3. the maximum surface pressure and the surface pressure on the proposed bearings;
4. the maximum glide speed and the glide speed involved of the bearing proposed;
5. the specific performance of the bearing involved with the published catalogue limits.

Re 1:

The load ratio (C/F) is a value for a specific use of a bearing according to formula (5).

$$(5) \quad (C/F)_{\text{exist}} \geq (C/F)_{\text{min}}$$

The common minimum values for (C/F) for different antifriction surfaces as listed in table 3, can be used to establish the required dynamic load rating C in accordance with formula (5a) by changing formula (5). By this means a suitable bearing size can be selected from the tables of this catalogue.

| | | | | | |
|----------------------|-------|-------|-------|--------|--------|
| $(C/F)_{\text{min}}$ | St/Ms | St/Bz | St/St | St/TBz | St/TNy |
| | 2 | 2 | 2 | 1,75 | 1,5 |

Table 3: Typical load ratios

$$(5a) \quad C_{\text{reg}} \geq (C/F)_{\text{min}} \cdot F_{\text{exist}} \quad [\text{kN}]$$

Technical Information

Re 2:

When the existing force affecting the bearing is a static load, it can be used as is for a comparison. When it is a dynamic load, it can be calculated by using formula (2), (3) or (4).

When a Rod End is mounted with a locking nut or retransfer with two nuts, the additional tensile stress at the male thread or the connecting rod has to be taken into consideration.

However the static or dynamic load must always be smaller than the maximum permitted load, which is calculated from the static load rating C_o using formula (6). This might have to be further reduced by the load factor f_B (picture 1) and the temperature factor f_T (table 4).

| | | | | | |
|------------------|------|------|------|------|------|
| Temperature C | 80° | 100° | 150° | 200° | 250° |
| Temperature F | 176° | 212° | 302° | 392° | 480° |
| greased | 1 | 1 | 1 | 0,8 | 0,5 |
| maintenance free | 1 | 1 | 0,8 | 0,5 | 0,3 |

Table 4: Temperature factor f_T

$$(6) \quad F_{r, \max} = C_o \cdot f_B \cdot f_T \quad [\text{kN}]$$

$$(6a) \quad F_{a, \max} = a \cdot F_{r, \max} \quad [\text{kN}]$$

If no bearing size is given in the application the required static load rating can be established by changing formula (6) and a Rod End can be selected from the tables accordingly.

$$(7) \quad C_{o, \text{reg}} \geq \frac{F_{\text{exist}}}{f_B \cdot f_T} \quad [\text{kN}]$$

Re 3:

The load on a mating surface can be worked out by using formula (8). It must be less than the standard value for surface load according to the antifriction combination of materials, selected as listed in table (1).

$$(8) \quad p_{\text{exist}} = p_{\max} / (C/F)_{\text{exist}} \quad [\text{N/mm}^2]$$

p_{\max} acc.to table 1, F acc.to formula (2),(3) or (4)

Re 4:

The existing average glide speed v_m is calculated according to formula (9) using the frequency of rotation of the crank K and the glide distance of the Spherical Plain Bearing G. (At one rotation of K it corresponds to the double arc b between the centres 1 and 2 in Picture 5 and thus to the double maximum oscillating angle β).

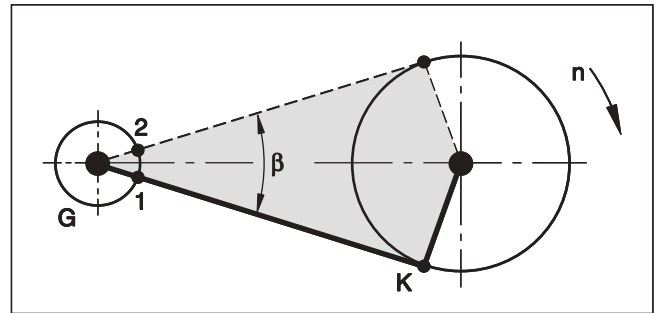

Picture 5: Oscillating angle β relative to crank rotation

$$(9) \quad v_{m, \text{exist}} = 2 \cdot b \cdot f = \frac{d_k \cdot \beta \cdot f}{1000 \cdot 57,3 \cdot 60} \quad [\text{m/s}]$$

Diameter of ball d_k [mm] and f [1/min]

In case where the bearing rotates fully β needs to be substituted by 180° . The slip speed has to be less than the speed permissible listed in table 5.

| V_{\max} [m/s] | Oscillation | Revolution |
|----------------------|-------------|---|
| Steel/Steel | 0,15 | 0,10 |
| Steel/Bronze (Brass) | 0,25 | 1,00 |
| Maintenance free | 0,25 | 0,35 <small>short temporary intervals only</small> |

Table 5: Maximum slip speed

Re 5:

The product $p \cdot v$ can be defined as a specific bearing performance P_L (see formula 10). Thus, an estimated value for the heat build-up per mm^2 of the Spherical Plain Bearing surface ist available, mainly dependent on the antifriction material combination, the lubrication/cooling applied and the surface pressure and glide speed. By increasing temperate the allowable surface pressure of maintenance free bearings is decreasing (picture 1 and 4).

$$(10) \quad P_{L, \text{exist}} = p_{\text{exist}} \cdot v_{\text{exist}} \quad \left[\frac{\text{N} \cdot \text{m}}{\text{mm}^2 \cdot \text{s}} = \frac{\text{W}}{\text{mm}^2} \right]$$

Slip speed v according to (9)

Surface pressure p according to (8)

After the selection of the bearing the following is valid:

$$P_{L, \text{exist}} \leq P_{L, \max}$$

| $P_{L, \max}$ [W/mm ²] | Steel/Bz, (Brass), (Steel) | Maintenance free |
|------------------------------------|----------------------------|------------------|
| | 0,5 | 1,3 |

Table 6: Maximum specific bearing performance

Technical Information

Bearing life calculations

In the case of a static load it is not necessary to calculate the working life. The permissible limit set at 80% of the breaking point allows the forces to act indefinitely.

In the case of dynamic loads calculating the bearing life is problematic. There are many, sometimes interdependent influences, that cannot always be taken into consideration. Therefore, a calculation of the bearing life can only be approximate. As an approximation the bearing has an increased life proportional to its load rating and also when used at a moderate speed.

Additional influences can be taken into account by making use of the factors in formula (11).

$$(11) \quad G_h \approx 3 \cdot f_L \cdot f_T \cdot f_G \cdot f_v \left(\frac{C/F}{v_m} \right)_{\text{exist}} \quad [\text{h}]$$

- f_L = Direction of load to table 7
- f_T = Temperature factor to table 4
- f_G = Glide factor to table 8
- f_v = Relubrication factor to table 9
- C/F = Load ratio
- v_m = Mean glide speed [m/s]

The direction of load factor indicates whether the direction of load is uni-directional, constant, variable or oscillating.

| Direction of load | Steel/Steel | Steel/Bz | Steel/PTFE |
|-------------------|-------------|----------|------------|
| unidirectional | 1 | 1 | 1 |
| varying | 2,5 | 2 | 1 |

Table 7: Directional load factors f_L

The slip factor f_G takes into account the materials used on the mating surfaces of a bearing. As a result the only distinction that can be made is between being maintenance-free (not lubricated) and where lubrication is necessary.

| $(C/F)_{\text{exist}}$ | 1,5 | 2 | 3 | 4 | 6 | 8 | 10 | 15 | 20 |
|------------------------|-----|-----|-----|-----|-----|-----|-----|-----|-----|
| maint. free | 1,5 | 2,0 | 2,5 | 3,0 | 3,5 | 4,0 | 4,3 | 4,7 | 5,0 |
| greased | 1,1 | 1,2 | 1,3 | 1,4 | 1,6 | 1,8 | 2,1 | 2,4 | 2,5 |

Table 8: Glide factors f_G

The relubrication factor f_v takes into account the extension of the bearing life G_h when regularly lubricated. The greater the surface pressure p_{exist} the more often the bearing has to be relubricated. If the bearing is only lubricated on commissioning as in the case of bearings with PTFE liners, $f_v = 1$ has to be inserted.

| p_{exist} [N/mm ²] | 5 | 10 | 25 | 40 |
|--|---|----|----|----|
| Regular regreasing regreaseable bearing | 6 | 4 | 3 | 2 |
| Initial greasing + PTFE | 1 | 1 | 1 | 1 |

Table 9: Relubrication factors f_v

Lubrication intervals are dependent on load conditions and therefore have to be set by the operator.

Calculation Examples

1. Example:

In a paper machine used for manufacturing writing pads a rod end with female thread is used. The dimensions of the components in the machine require size 16, and the following values are also given:

Variable radial load through $F_r = \pm 2$ kN; No axial load

Max. angle of misalignment $\beta = 20^\circ$; Oscillating interval $f = 150/\text{min.}$; operating temperature $T = +50^\circ$ Celsius, $+122^\circ$ Fahrenheit

Regular lubrication possible

1. Initial selection of Rod End

- a) **Type of Bearing** Rod Ends Series GI, GIS, GIXS, GIRS, GIO can be used when relubricating. However, the following have to be excluded
- GIO, because it cannot be lubricated and only moderate movements are possible.
 - GIRS, a stainless steel type is unnecessary as the working environment is not corrosive. So we can choose from female rod end types GI, GIS, GIXS.

- b) **Size** The required diameter of the ball is 16 mm and the following values for GIS can be ascertained from the brochure on pages 26 and 64.

$$d_k = 28,6 \text{ mm}; C_o = 32,0 \text{ kN}; C = 21,5 \text{ kN}$$

b1) required static load rating C_o [formula 7 + picture 1 + table 4]

$$C_{o, \text{req}} \geq \frac{F_{\text{exist}}}{f_B \cdot f_T} = \frac{2}{0,5 \cdot 1} = \underline{\underline{4 \text{ kN}}}$$

b2) required dynamic load rating C [formula 5a + table 3]

$$C_{\text{req}} \geq (C/F)_{\text{min}} \cdot F_{\text{exist}} = 2 \cdot 2 = \underline{\underline{4 \text{ kN}}}$$

Check

$$C_{o, \text{exist}} = 32,0 \text{ kN} > C_{o, \text{req}} = 4 \text{ kN}$$

$$C_{\text{exist}} = 21,5 \text{ kN} > C_{\text{req}} = 4 \text{ kN}$$

$$F_r = 2 \text{ kN} \leq F_{r, \text{max}} = C_o \cdot f_B \cdot f_T = 32,0 \cdot 0,5 \cdot 1 = 16,0 \text{ kN}$$

2. Checking the surface pressure [formula 8 + table 1]

$$p_{\text{exist}} = \frac{p_{\text{max}}}{(C/F)_{\text{exist}}} = \frac{50}{21,5/2} = \frac{50}{10,75} = \underline{\underline{4,65 \text{ N/mm}^2}} < p_{\text{max}} = 50 \text{ N/mm}^2$$

3. Checking the slip speed [formula 9 + table 5]

$$v_{m, \text{exist}} = \frac{d_k \cdot \beta \cdot f}{1000 \cdot 57,3 \cdot 60} = \frac{28,6 \cdot 20 \cdot 150}{1000 \cdot 57,3 \cdot 60} = \underline{\underline{0,025 \text{ m/s}}} < v_{\text{max}} = 0,25 \text{ m/s}$$

4. Checking the specific bearing performance [formula 10 + table 6]

$$P_{L, \text{exist}} = p_{\text{exist}} \cdot v_{m, \text{exist}} = 4,65 \cdot 0,025 = \underline{\underline{0,12 \text{ W/mm}^2}} < P_{L, \text{max}} = 0,5 \text{ W/mm}^2$$

5. Calculation of bearing life [formula 11 + table 7 + 4 + 8 + 9]

$$G_h \approx 3 \cdot f_L \cdot f_T \cdot f_G \cdot f_V \cdot \left(\frac{C}{F} \right)_{\text{exist}} = 3 \cdot 2 \cdot 1 \cdot 2,1 \cdot 6 \cdot \frac{10,75}{0,025} = \underline{\underline{32.500 \text{ hrs.}}}$$

6. Final selection

Following steps 1b to 5. - the calculations for rod ends GI 16 and GIXS 16 can be checked. When making a decision on the bearing to use, design, application and price have to be taken into consideration for each type.

Calculation Examples

2. Example:

In a mechanical handling facility multi-directional radial loads are applied to the rod end. These loads are the same as shown in illustration 4, page 19. Four separate loads $F_{r,i}$ with the four appropriate time components have been substituted as shown below:

$F_{r1} = 2 \text{ kN}$, $t_1 = 50\%$; $F_{r2} = 4 \text{ kN}$, $t_2 = 16\%$; $F_{r3} = 2,4 \text{ kN}$, $t_3 = 24\%$; $F_{r4} = 1 \text{ kN}$, $t_4 = 10\%$;

Additionally the rod end is subjected to a constant axial load $F_a = 0,65 \text{ kN}$

Further operating conditions: max. angle $\beta = 30^\circ$; oscillation frequency $f = 60/\text{min.}$; max. temperature 70°C

1. Initial selection of Rod End

a) **Type of bearing** As regular lubrication is not possible due to poor accessibility a maintenance free type must be used. Rod Ends GASW, GAXSW, GARSW, GAOW could be suitable, but the following series have to be ruled out.

- GAOW - these Rod Ends are only suitable for restricted movement.

- GARSW - because the working environment is not corrosive.

This leaves the size of the male thread version of type GASW to be established.

b) **Size** b0) mean and equivalent bearing load [formula 3 + 4 + table 2]

$$F_m = 0,1 \sqrt{\sum F_i^2 \cdot t_i} = 0,1 \sqrt{2^2 \cdot 50 + 4^2 \cdot 16 + 2,4^2 \cdot 24 + 1^2 \cdot 10} = \underline{\underline{2,46 \text{ kN}}}$$

$$F_e = F_m + Y \cdot F_a = 2,46 + 1,26 \cdot 0,65 = \underline{\underline{3,28 \text{ kN}}} \quad Y = 1,26 \text{ for } F_a/F_m = 0,65/2,46 = 0,26$$

b1) required static load rating C_o [formula 7 + picture 1 + table 4]

$$C_{o, \text{req}} \geq \frac{F_{\text{exist}, e}}{f_B \cdot f_T} = \frac{3,28}{0,5 \cdot 1} = \underline{\underline{6,56 \text{ kN}}}$$

b2) required dynamic load rating C [formula 5a + table 3]

$$C_{\text{req}} \geq (C/F)_{\text{min}} \cdot F_{\text{exist}} = 1,75 \cdot 3,28 = \underline{\underline{5,75 \text{ kN}}}$$

c) **Bearing selected GASW 12** with $d_k = 22,2 \text{ mm}$ and $C_o = 23,5 \text{ kN}$ $C = 32,0 \text{ kN}$

Check [formula 6 + 6a]

$$C_{o, \text{exist}} = 23,5 \text{ kN} > C_{o, \text{req}} = 6,56 \text{ kN} \quad F_{r2} = 4,00 \text{ kN} \leq F_{r, \text{max}} = C_o \cdot f_B \cdot f_T = 23,5 \cdot 0,5 \cdot 1 = 11,75 \text{ kN}$$

$$C_{\text{exist}} = 32,0 \text{ kN} > C_{\text{req}} = 5,75 \text{ kN} \quad F_a = 0,65 \text{ kN} \leq F_{a, \text{max}} = a \cdot F_{r, \text{max}} = 0,2 \cdot 11,75 = 2,35 \text{ kN}$$

[a = 0,2 see formula 1]

Note: When selecting the size the dynamic load C_{req} should not exceed the static load $C_{o, \text{exist}}$

2. Checking the surface pressure [formula 8 + table 1]

$$p_{\text{exist}} = \frac{p_{\text{max}}}{(C/F)_{\text{exist}}} = \frac{150}{32,0/3,28} = \frac{150}{9,75} = \underline{\underline{15,38 \text{ N/mm}^2}} < p_{\text{max}} = 150 \text{ N/mm}^2$$

3. Checking the slip speed [formula 9 + table 5]

$$v_{m, \text{exist}} = \frac{d_k \cdot \beta \cdot f}{1000 \cdot 57,3 \cdot 60} = \frac{22,2 \cdot 30 \cdot 60}{1000 \cdot 57,3 \cdot 60} = \underline{\underline{0,011 \text{ m/s}}} < v_{\text{max}} = 0,25 \text{ m/s}$$

4. Checking the specific bearing performance [formula 10 + table 6]

$$P_{L, \text{exist}} = p_{\text{exist}} \cdot v_{m, \text{exist}} = 15,38 \cdot 0,011 = 0,17 \text{ W/mm}^2 < P_{L, \text{max}} = 1,3 \text{ W/mm}^2$$

5. Calculation of bearing life [formula 11 + table 7 + 4 + 8 + 9]

$$G_h \approx 3 \cdot f_L \cdot f_T \cdot f_G \cdot f_v \cdot \left(\frac{C}{F} \right)_{\text{exist}} = 3 \cdot 1 \cdot 1 \cdot 4,2 \cdot 1 \cdot \frac{9,75}{0,011} = \underline{\underline{11.100 \text{ hrs.}}}$$

6. Final selection

Steps 1c to 5 can then be repeated for series GAXSW so that after comparing the required material strength, price etc. of each type, a final decision can be taken.

Rod Ends Series K - Standard

Series GI

Rod End with female thread regreasable through grease nipple in the housing

Especially suited for axial loads

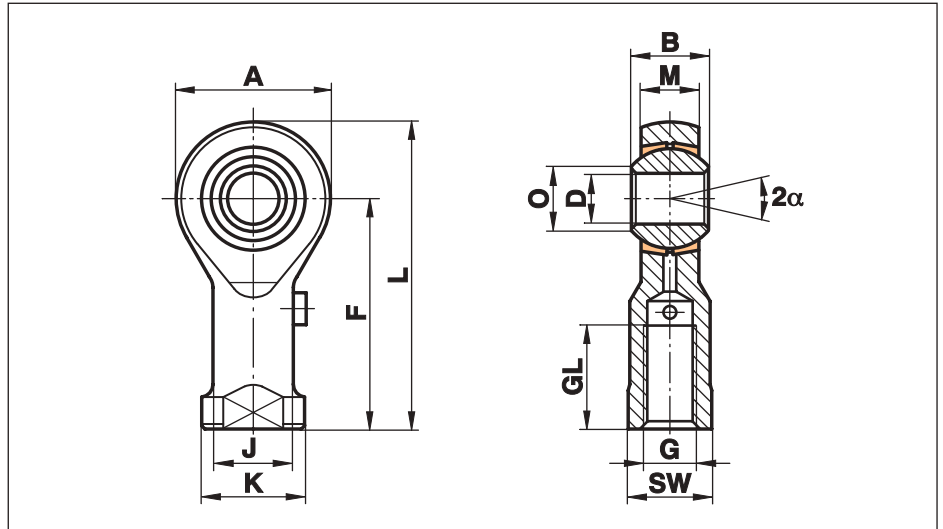

| Size (D H7) | B | M | A | F | L | K | J | O | SW | G | GL | Static load C ₀ kN | Dynamic load C kN | Limiting speed rev/min | Maximum Pivoting Angle α (°) | Weight g |
|-------------|----|-------|----|----|-----|----|------|------|----|----------|----|-------------------------------|-------------------|------------------------|------------------------------|----------|
| 5 | 8 | 6,00 | 18 | 27 | 36 | 11 | 9,0 | 7,7 | 9 | M 5 | 10 | 9,9 | 2,5 | 900 | 13 | 18 |
| 6 | 9 | 6,75 | 20 | 30 | 40 | 13 | 10,0 | 8,9 | 11 | M 6 | 12 | 11,9 | 3,2 | 760 | 13 | 27 |
| 8 | 12 | 9,00 | 24 | 36 | 48 | 16 | 12,5 | 10,4 | 13 | M 8 | 16 | 17,1 | 5,4 | 620 | 14 | 46 |
| 10 | 14 | 10,50 | 28 | 43 | 57 | 19 | 15,0 | 12,9 | 17 | M 10 | 20 | 21,4 | 7,5 | 500 | 13 | 76 |
| 12 | 16 | 12,00 | 32 | 50 | 66 | 22 | 17,5 | 15,4 | 19 | M 12 | 22 | 27,0 | 10,0 | 450 | 13 | 115 |
| 14 | 19 | 13,50 | 36 | 57 | 75 | 25 | 20,0 | 16,8 | 22 | M 14 | 25 | 24,5 | 13,0 | 360 | 16 | 170 |
| 16 | 21 | 15,00 | 42 | 64 | 85 | 27 | 22,0 | 19,3 | 22 | M 16 | 28 | 37,0 | 16,0 | 350 | 15 | 230 |
| 18 | 23 | 16,50 | 46 | 71 | 94 | 31 | 25,0 | 21,8 | 27 | M 18x1,5 | 32 | 43,0 | 19,5 | 320 | 15 | 320 |
| 20 | 25 | 18,00 | 50 | 77 | 102 | 34 | 27,5 | 24,3 | 32 | M 20x1,5 | 33 | 49,5 | 23,5 | 280 | 14 | 415 |
| 22 | 28 | 20,00 | 54 | 84 | 111 | 37 | 30,0 | 25,8 | 32 | M 22x1,5 | 37 | 57,0 | 29,0 | 250 | 15 | 540 |
| 25 | 31 | 22,00 | 60 | 94 | 124 | 42 | 33,5 | 29,6 | 36 | M 24x2 | 42 | 68,0 | 35,0 | 230 | 15 | 750 |

only for short-term revolutions recommended

Materials:

Housing: up to size 12 turned from free-cutting steel to 9SMnPb28K galvanised, from size 14 forged from heat-treated steel C22, M1023 galvanised

Insert: Special brass to CuZn38Al1

Ball: Bearing steel to 100Cr6, Aisi 52100, hardened, ground, polished

Cetop connections see page 54.

Rod Ends Series K - Standard

Series GA

Rod End with male thread regreasable through grease nipple in the housing

Especially suited for axial loads

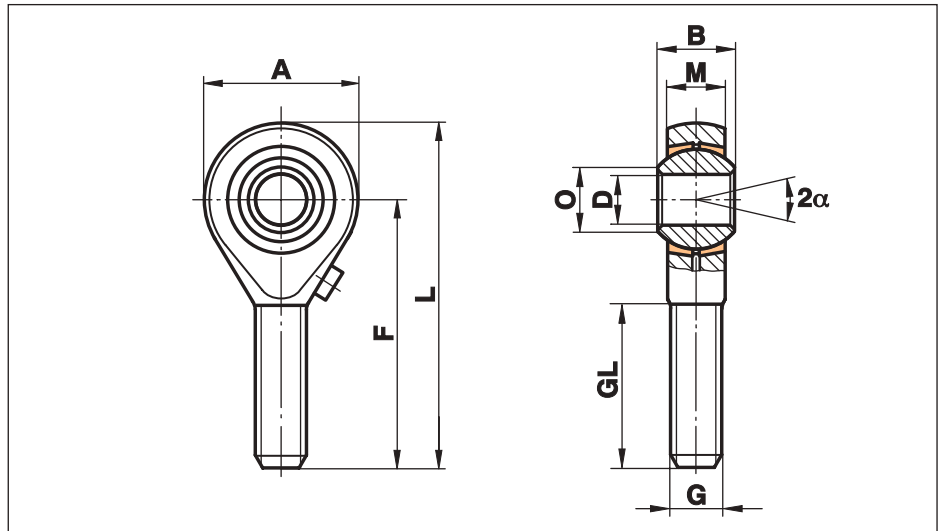

| Size (D H7) | B | M | A | F | L | O | G | GL | Static load C ₀ kN | Dynamic load C kN | Limiting speed rev/min | Maximum Pivoting Angle α (°) | Weight g |
|-----------------|----|-------|----|----|-----|------|----------|----|-------------------------------|-------------------|------------------------|------------------------------|----------|
| 5 ¹⁾ | 8 | 6,00 | 18 | 33 | 42 | 7,7 | M 5 | 19 | 4,3 | 2,5 | 900 | 13 | 13 |
| 6 | 9 | 6,75 | 20 | 36 | 46 | 8,9 | M 6 | 21 | 6,0 | 3,2 | 760 | 13 | 20 |
| 8 | 12 | 9,00 | 24 | 42 | 54 | 10,4 | M 8 | 25 | 11,0 | 5,4 | 620 | 14 | 33 |
| 10 | 14 | 10,50 | 28 | 48 | 62 | 12,9 | M 10 | 28 | 17,4 | 7,5 | 500 | 13 | 56 |
| 12 | 16 | 12,00 | 32 | 54 | 70 | 15,4 | M 12 | 32 | 25,5 | 10,0 | 450 | 13 | 87 |
| 14 | 19 | 13,50 | 36 | 60 | 78 | 16,8 | M 14 | 36 | 24,5 | 13,0 | 360 | 16 | 129 |
| 16 | 21 | 15,00 | 42 | 66 | 87 | 19,3 | M 16 | 40 | 36,5 | 16,0 | 350 | 15 | 189 |
| 18 | 23 | 16,50 | 46 | 72 | 95 | 21,8 | M 18x1,5 | 44 | 43,0 | 19,5 | 320 | 15 | 267 |
| 20 | 25 | 18,00 | 50 | 78 | 103 | 24,3 | M 20x1,5 | 47 | 49,5 | 23,5 | 280 | 14 | 348 |
| 22 | 28 | 20,00 | 54 | 84 | 111 | 25,8 | M 22x1,5 | 51 | 57,0 | 29,0 | 250 | 15 | 443 |
| 25 | 31 | 22,00 | 60 | 94 | 124 | 29,6 | M 24x2 | 57 | 68,0 | 35,0 | 230 | 15 | 600 |

only for short-term revolutions recommended

Materials:

Housing: up to size 12 turned from free-cutting steel to 9SMnPb28K galvanised, from size 14 forged from heat-treated steel C22, M1023 galvanised

Insert: Special brass to CuZn38Al1

Ball: Bearing steel to 100Cr6, Aisi 52100, hardened, ground, polished

¹⁾ without lubrication hole

Rod Ends Series K - requiring maintenance

Series GIS

Rod End with female thread regreasable through grease nipple in the housing

Especially suited for high speed applications

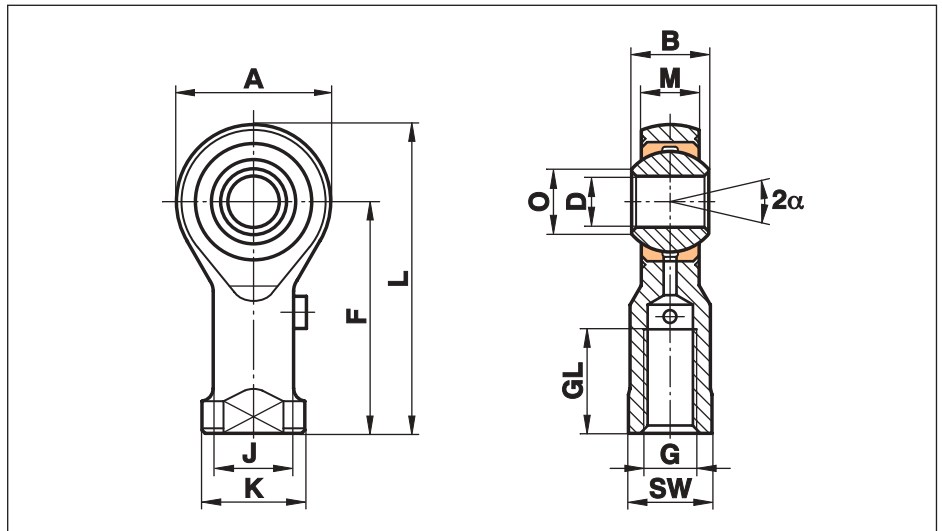

| Size (D H7) | B | M | A | F | L | K | J | O | SW | G | GL | Static load C ₀ kN | Dynamic load C kN | Limiting speed rev/min | Maximum Pivoting Angle α (°) | Weight g |
|-----------------|------|-------|-----|-----|-------|------|------|------|------|----------|----|-------------------------------|-------------------|------------------------|------------------------------|----------|
| 2 ¹⁾ | 4,5 | 3,60 | 9 | 16 | 20,5 | 4,5 | 3,8 | 2,6 | 4,0 | M 2 | 7 | 3,0 | 1,1 | | 16 | 3 |
| 3 ¹⁾ | 6,0 | 4,50 | 14 | 21 | 27,0 | 6,5 | 5,0 | 5,1 | 5,5 | M 3 | 10 | 4,1 | 1,8 | | 14 | 6 |
| 5 | 8,0 | 6,00 | 18 | 27 | 36,0 | 11,0 | 9,0 | 7,7 | 9,0 | M 5 | 10 | 8,0 | 3,3 | 1200 | 13 | 18 |
| 6 | 9,0 | 6,75 | 20 | 30 | 40,0 | 13,0 | 10,0 | 8,9 | 11,0 | M 6 | 12 | 8,9 | 4,3 | 1500 | 13 | 27 |
| 8 | 12,0 | 9,00 | 24 | 36 | 48,0 | 16,0 | 12,5 | 10,4 | 13,0 | M 8 | 16 | 14,1 | 7,1 | 1200 | 14 | 46 |
| 10 | 14,0 | 10,50 | 28 | 43 | 57,0 | 19,0 | 15,0 | 12,9 | 17,0 | M 10 | 20 | 19,3 | 10,0 | 1000 | 13 | 76 |
| 12 | 16,0 | 12,00 | 32 | 50 | 66,0 | 22,0 | 17,5 | 15,4 | 19,0 | M 12 | 22 | 23,5 | 13,5 | 860 | 13 | 115 |
| 14 | 19,0 | 13,50 | 36 | 57 | 75,0 | 25,0 | 20,0 | 16,8 | 22,0 | M 14 | 25 | 21,0 | 17,0 | 750 | 16 | 170 |
| 16 | 21,0 | 15,00 | 42 | 64 | 85,0 | 27,0 | 22,0 | 19,3 | 22,0 | M 16 | 28 | 32,0 | 21,5 | 660 | 15 | 230 |
| 18 | 23,0 | 16,50 | 46 | 71 | 94,0 | 31,0 | 25,0 | 21,8 | 27,0 | M 18x1,5 | 32 | 38,5 | 26,0 | 600 | 15 | 320 |
| 20 | 25,0 | 18,00 | 50 | 77 | 102,0 | 34,0 | 27,5 | 24,3 | 32,0 | M 20x1,5 | 33 | 44,0 | 31,5 | 540 | 14 | 415 |
| 22 | 28,0 | 20,00 | 54 | 84 | 111,0 | 37,0 | 30,0 | 25,8 | 32,0 | M 22x1,5 | 37 | 53,0 | 38,0 | 500 | 15 | 540 |
| 25 | 31,0 | 22,00 | 60 | 94 | 124,0 | 42,0 | 33,5 | 29,6 | 36,0 | M 24x2 | 42 | 62,0 | 47,0 | 440 | 15 | 750 |
| 30 | 37,0 | 25,00 | 70 | 110 | 145,0 | 51,0 | 40,0 | 34,8 | 41,0 | M 30x2 | 51 | 82,0 | 64,0 | 370 | 17 | 1130 |
| 35 | 43,0 | 28,00 | 80 | 125 | 165,0 | 58,0 | 46,0 | 37,7 | 50,0 | M 36x2 | 56 | 101,0 | 80,0 | 330 | 19 | 1600 |
| 40 | 49,0 | 35,00 | 90 | 142 | 187,0 | 69,0 | 57,0 | 44,2 | 60,0 | M 42x2 | 60 | 124,0 | 116,0 | 290 | 16 | 2770 |
| 50 | 60,0 | 45,00 | 116 | 160 | 218,0 | 78,0 | 65,0 | 55,9 | 65,0 | M 48x2 | 65 | 308,0 | 185,0 | 230 | 14 | 5000 |

only for short-term revolutions recommended

Materials:

Housing: up to size 12 turned from free-cutting steel to 9SMnPb28K galvanised, from size 14 forged from heat-treated steel C22, M1023 galvanised
Size 50 turned from heat-treated steel C45 galvanised

Insert: Special high strength bronze to CuSn8

Ball: Bearing steel to 100Cr6, hardened, ground, polished

This series is also available sealed (see page 52) or with threaded bolt (see page 53).

Cetop connections see page 54.

¹⁾ without lubrication hole

Rod Ends Series K - requiring maintenance

Series GAS

Rod End with male thread regreasable through grease nipple in the housing

Especially suited for high speed applications

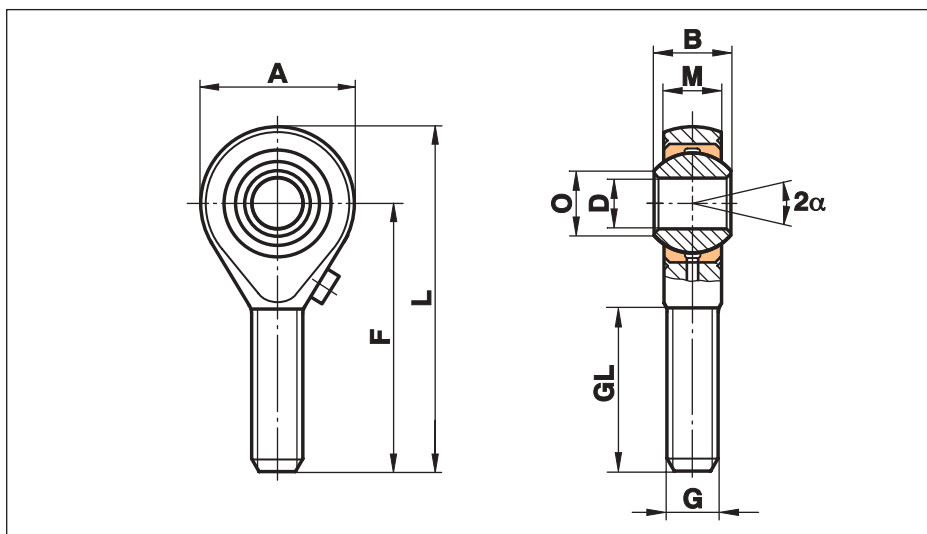

| Size (D H7) | B | M | A | F | L | O | G | GL | Static load C ₀ kN | Dynamic load C kN | Limiting speed rev/min | Maximum Pivoting Angle α (°) | Weight g |
|-----------------|------|-------|-----|-----|-------|------|----------|-----|-------------------------------|-------------------|------------------------|------------------------------|----------|
| 2 ¹⁾ | 4,5 | 3,60 | 9 | 20 | 24,5 | 2,6 | M 2 | 12 | 0,6 | 1,1 | | 16 | 3 |
| 3 ¹⁾ | 6,0 | 4,50 | 14 | 26 | 33,0 | 5,1 | M 3 | 15 | 1,5 | 1,8 | | 14 | 6 |
| 5 ¹⁾ | 8,0 | 6,00 | 18 | 33 | 42,0 | 7,7 | M 5 | 19 | 4,3 | 3,3 | | 13 | 13 |
| 6 | 9,0 | 6,75 | 20 | 36 | 46,0 | 8,9 | M 6 | 21 | 6,0 | 4,3 | 1500 | 13 | 20 |
| 8 | 12,0 | 9,00 | 24 | 42 | 54,0 | 10,4 | M 8 | 25 | 11,0 | 7,1 | 1200 | 14 | 33 |
| 10 | 14,0 | 10,50 | 28 | 48 | 62,0 | 12,9 | M 10 | 28 | 17,4 | 10,0 | 1000 | 13 | 56 |
| 12 | 16,0 | 12,00 | 32 | 54 | 70,0 | 15,4 | M 12 | 32 | 23,5 | 13,5 | 860 | 13 | 87 |
| 14 | 19,0 | 13,50 | 36 | 60 | 78,0 | 16,8 | M 14 | 38 | 21,0 | 17,0 | 750 | 16 | 129 |
| 16 | 21,0 | 15,00 | 42 | 66 | 87,0 | 19,3 | M 16 | 40 | 32,0 | 21,5 | 660 | 15 | 189 |
| 18 | 23,0 | 16,50 | 46 | 72 | 95,0 | 21,8 | M 18x1,5 | 44 | 38,5 | 26,0 | 600 | 15 | 267 |
| 20 | 25,0 | 18,00 | 50 | 78 | 103,0 | 24,3 | M 20x1,5 | 47 | 44,0 | 31,5 | 540 | 14 | 348 |
| 22 | 28,0 | 20,00 | 54 | 84 | 111,0 | 25,8 | M 22x1,5 | 51 | 53,0 | 38,0 | 500 | 15 | 443 |
| 25 | 31,0 | 22,00 | 60 | 94 | 124,0 | 29,6 | M 24x2 | 58 | 62,0 | 47,0 | 440 | 15 | 600 |
| 30 | 37,0 | 25,00 | 70 | 110 | 145,0 | 34,8 | M 30x2 | 71 | 82,0 | 64,0 | 370 | 17 | 1030 |
| 35 | 43,0 | 28,00 | 80 | 125 | 165,0 | 37,7 | M 36x2 | 73 | 101,0 | 80,0 | 330 | 19 | 1600 |
| 40 | 49,0 | 35,00 | 90 | 142 | 187,0 | 44,2 | M 42x2 | 78 | 124,0 | 116,0 | 290 | 16 | 2550 |
| 50 | 60,0 | 45,00 | 116 | 185 | 243,0 | 55,9 | M 48x2 | 105 | 308,0 | 185,0 | 230 | 14 | 4800 |

only for short-term revolutions recommended

Materials:

Housing: up to size 12 turned from free-cutting steel to 9SMnPb28K galvanised, from size 14 forged from heat-treated steel C22, M1023 galvanised
Size 50 turned from heat-treated steel C45 galvanised

Insert: Special high strength bronze to CuSn8

Ball: Bearing steel to 100Cr6, hardened, ground, polished

This series is also available sealed (see page 52) or with threaded bolt (see page 53).

¹⁾ without lubrication hole

Rod Ends Series K - Extra Heavy Duty

Series GIXS

Rod End with female thread regreasable through grease nipple in the housing

Especially suitable for high pressure and tension loads

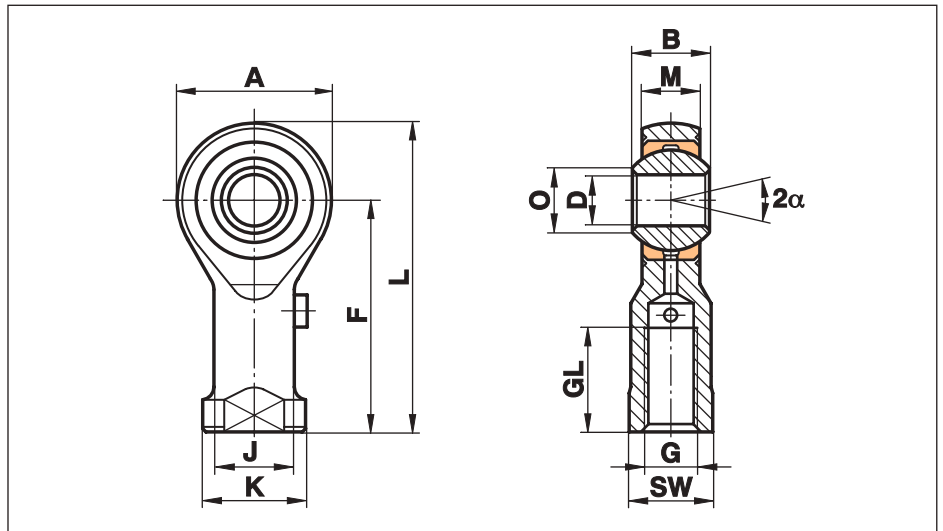

| Size (D H7) | B | M | A | F | L | K | J | O | SW | G | GL | Static load C ₀ kN | Dynamic load C kN | Limiting speed rev/min | Maximum Pivoting Angle α (°) | Weight g |
|-------------|----|-------|----|-----|-----|----|------|------|----|----------|----|-------------------------------|-------------------|------------------------|------------------------------|----------|
| 6 | 9 | 6,75 | 20 | 30 | 40 | 13 | 10,0 | 8,9 | 11 | M 6 | 12 | 16,7 | 4,3 | 1500 | 13 | 27 |
| 8 | 12 | 9,00 | 24 | 36 | 48 | 16 | 12,5 | 10,4 | 13 | M 8 | 16 | 25,5 | 7,1 | 1200 | 14 | 46 |
| 10 | 14 | 10,50 | 28 | 43 | 57 | 19 | 15,0 | 12,9 | 17 | M 10 | 20 | 34,8 | 10,0 | 1000 | 13 | 76 |
| 12 | 16 | 12,00 | 32 | 50 | 66 | 22 | 17,5 | 15,4 | 19 | M 12 | 22 | 42,0 | 13,3 | 860 | 13 | 115 |
| 14 | 19 | 13,50 | 36 | 57 | 75 | 25 | 20,0 | 16,8 | 22 | M 14 | 25 | 57,0 | 17,0 | 750 | 16 | 170 |
| 16 | 21 | 15,00 | 42 | 64 | 85 | 27 | 22,0 | 19,3 | 22 | M 16 | 28 | 67,5 | 21,5 | 660 | 15 | 230 |
| 18 | 23 | 16,50 | 46 | 71 | 94 | 31 | 25,0 | 21,8 | 27 | M 18x1,5 | 32 | 81,5 | 26,0 | 600 | 15 | 320 |
| 20 | 25 | 18,00 | 50 | 77 | 102 | 34 | 27,5 | 24,3 | 32 | M 20x1,5 | 33 | 93,5 | 31,5 | 540 | 14 | 415 |
| 22 | 28 | 20,00 | 54 | 84 | 111 | 37 | 30,0 | 25,8 | 32 | M 22x1,5 | 37 | 114,0 | 38,0 | 500 | 15 | 540 |
| 25 | 31 | 22,00 | 60 | 94 | 124 | 42 | 33,5 | 29,6 | 36 | M 24x2 | 42 | 135,0 | 47,0 | 440 | 15 | 750 |
| 30 | 37 | 25,00 | 70 | 110 | 145 | 51 | 40,0 | 34,8 | 41 | M 30x2 | 51 | 184,0 | 64,0 | 370 | 17 | 1130 |

only for short-term revolutions recommended

Materials:

Housing: forged from heat-treated galvanised steel 42CrMo4 Aisi 4140

Insert: Special high strength bronze to CuSn8

Ball: Bearing steel to 100Cr6, Aisi 52100, hardened, ground, polished

This series is also available sealed (see page 52) or with threaded bolt (see page 53).

Cetop connections see page 54.

Rod Ends Series K - Extra Heavy Duty

Series GAXS

Rod End with male thread regreasable through grease nipple in the housing

Especially suitable for high pressure and tension loads

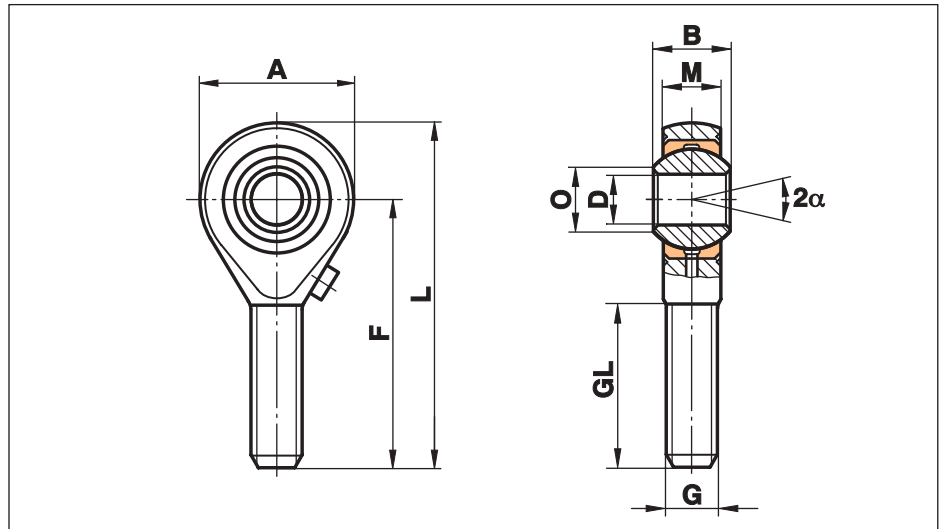

| Size (D H7) | B | M | A | F | L | O | G | GL | Static load C ₀ kN | Dynamic load C kN | Limiting speed rev/min | Maximum Pivoting Angle α (°) | Weight g |
|-------------|----|-------|----|-----|-----|------|----------|----|-------------------------------|-------------------|------------------------|---|----------|
| 6 | 9 | 6,75 | 20 | 36 | 46 | 8,9 | M 6 | 21 | 9,8 | 4,3 | 1500 | only for short-term revolutions recommended | 20 |
| 8 | 12 | 9,00 | 24 | 42 | 54 | 10,4 | M 8 | 25 | 19,5 | 7,1 | 1200 | | 33 |
| 10 | 14 | 10,50 | 28 | 48 | 62 | 12,9 | M 10 | 28 | 31,4 | 10,0 | 1000 | | 56 |
| 12 | 16 | 12,00 | 32 | 54 | 70 | 15,4 | M 12 | 32 | 42,0 | 13,5 | 860 | | 87 |
| 14 | 19 | 13,50 | 36 | 60 | 78 | 16,8 | M 14 | 38 | 57,0 | 17,0 | 750 | | 129 |
| 16 | 21 | 15,00 | 42 | 66 | 87 | 19,3 | M 16 | 40 | 67,5 | 21,5 | 660 | | 189 |
| 18 | 23 | 16,50 | 46 | 72 | 95 | 21,8 | M 18x1,5 | 44 | 81,5 | 26,0 | 600 | | 267 |
| 20 | 25 | 18,00 | 50 | 78 | 103 | 24,3 | M 20x1,5 | 47 | 93,5 | 31,5 | 540 | | 348 |
| 22 | 28 | 20,00 | 54 | 84 | 111 | 25,8 | M 22x1,5 | 51 | 114,0 | 38,0 | 500 | | 443 |
| 25 | 31 | 22,00 | 60 | 94 | 124 | 29,6 | M 24x2 | 57 | 135,0 | 47,0 | 440 | | 600 |
| 30 | 37 | 25,00 | 70 | 110 | 145 | 34,8 | M 30x2 | 71 | 184,0 | 64,0 | 370 | 1030 | |

Materials:

Housing: forged from heat-treated galvanised steel 42CrMo4 Aisi 4140

Insert: Special high strength bronze to CuSn8

Ball: Bearing steel to 100Cr6, Aisi 52100, hardened, ground, polished

This series is also available sealed (see page 52) or with threaded bolt (see page 53).

Cetop connections see page 54.

Rod Ends Series K - stainless housing - requiring maintenance

Series GIRS

Rod End with female thread regreasable through grease nipple in the housing

For use in corrosive environments

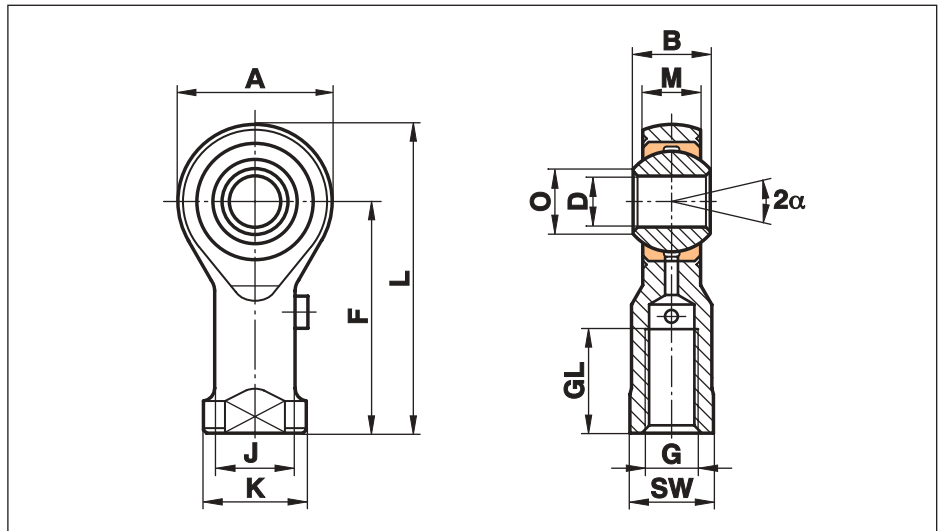

| Size (D H7) | B | M | A | F | L | K | J | O | SW | G | GL | Static load C ₀ kN | Dynamic load C kN | Limiting speed rev/min | Maximum Pivoting Angle α (°) | Weight g |
|-----------------|----|-------|----|-----|-----|------|------|------|------|----------|----|-------------------------------|-------------------|------------------------|------------------------------|----------|
| 3 ¹⁾ | 6 | 4,50 | 14 | 21 | 27 | 6,5 | 5,0 | 5,1 | 5,5 | M 3 | 10 | 8,0 | 1,8 | | 14 | 6 |
| 5 | 8 | 6,00 | 18 | 27 | 36 | 11,0 | 9,0 | 7,7 | 9,0 | M 5 | 10 | 11,8 | 3,3 | 1200 | 13 | 18 |
| 6 | 9 | 6,75 | 20 | 30 | 40 | 13,0 | 10,0 | 8,9 | 11,0 | M 6 | 12 | 13,1 | 4,3 | 1500 | 13 | 27 |
| 8 | 12 | 9,00 | 24 | 36 | 48 | 16,0 | 12,5 | 10,4 | 13,0 | M 8 | 16 | 20,7 | 7,1 | 1200 | 14 | 46 |
| 10 | 14 | 10,50 | 28 | 43 | 57 | 19,0 | 15,0 | 12,9 | 17,0 | M 10 | 20 | 28,3 | 10,0 | 1000 | 13 | 76 |
| 12 | 16 | 12,00 | 32 | 50 | 66 | 22,0 | 17,5 | 15,4 | 19,0 | M 12 | 22 | 34,5 | 13,5 | 860 | 13 | 115 |
| 14 | 19 | 13,50 | 36 | 57 | 75 | 25,0 | 20,0 | 16,8 | 22,0 | M 14 | 25 | 39,5 | 17,0 | 750 | 16 | 170 |
| 16 | 21 | 15,00 | 42 | 64 | 85 | 27,0 | 22,0 | 19,3 | 22,0 | M 16 | 28 | 60,5 | 21,5 | 660 | 15 | 230 |
| 18 | 23 | 16,50 | 46 | 71 | 94 | 31,0 | 25,0 | 21,8 | 27,0 | M 18x1,5 | 32 | 73,0 | 26,0 | 600 | 15 | 320 |
| 20 | 25 | 18,00 | 50 | 77 | 102 | 34,0 | 27,5 | 24,3 | 32,0 | M 20x1,5 | 33 | 83,0 | 31,5 | 540 | 14 | 415 |
| 22 | 28 | 20,00 | 54 | 84 | 111 | 37,0 | 30,0 | 25,8 | 32,0 | M 22x1,5 | 37 | 100,0 | 38,0 | 500 | 15 | 540 |
| 25 | 31 | 22,00 | 60 | 94 | 124 | 42,0 | 33,5 | 29,6 | 36,0 | M 24x2 | 42 | 118,0 | 47,1 | 440 | 15 | 750 |
| 30 | 37 | 25,00 | 70 | 110 | 145 | 51,0 | 40,0 | 34,8 | 41,0 | M 30x2 | 51 | 155,0 | 64,0 | 370 | 17 | 1130 |
| 35 | 43 | 28,00 | 80 | 125 | 165 | 58,0 | 46,0 | 37,7 | 50,0 | M 36x2 | 56 | 191,0 | 80,0 | 330 | 19 | 1600 |
| 40 | 49 | 35,00 | 90 | 142 | 187 | 69,0 | 57,0 | 44,2 | 60,0 | M 42x2 | 60 | 235,0 | 116,0 | 290 | 16 | 2770 |

only for short-term revolutions recommended

Materials:

Housing: Stainless steel to 1.4057, Aisi 431, forged, polished size 40 turned from stainless steel to 1.4057, Aisi 431

Insert: Special high strength bronze to CuSn8

Ball: Bearing steel to 100Cr6, Aisi 52100, hardened, ground, polished, hard chrome plated on the running surface

On request: other slide pairings possible

This series is also available sealed (see page 52) or with threaded bolt (see page 53).

Cetop connections see page 54.

¹⁾ without lubrication hole

Rod Ends Series K - stainless housing - requiring maintenance

Series GARS

Rod End with male thread regreasable through grease nipple in the housing

For use in corrosive environments

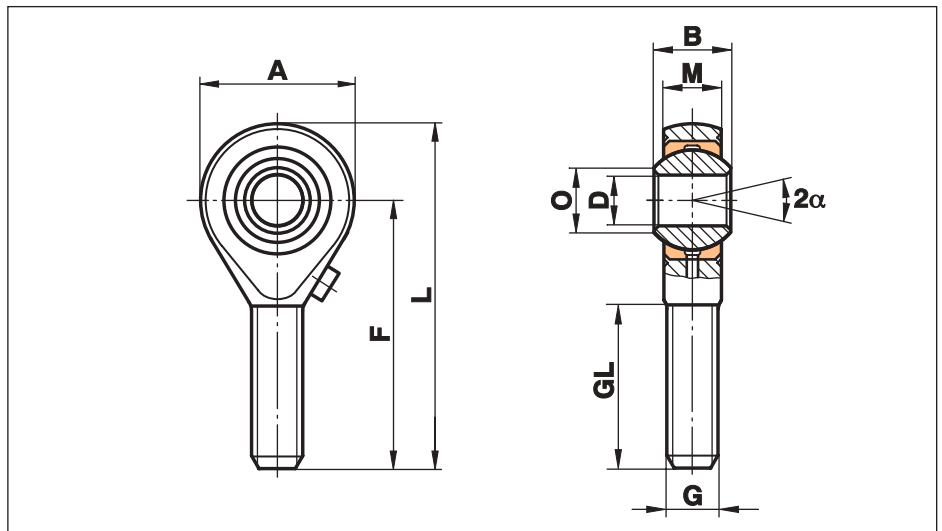

| Size (D H7) | B | M | A | F | L | O | G | GL | Static load C ₀ kN | Dynamic load C kN | Limiting speed rev/min | Maximum Pivoting Angle α (°) | Weight g | |
|-----------------|----|-------|----|-----|-----|------|----------|----|-------------------------------|-------------------|---|------------------------------|----------|------|
| 3 ¹⁾ | 6 | 4,50 | 14 | 26 | 33 | 5,1 | M 3 | 15 | 7,0 | 1,8 | only for short-term revolutions recommended | 14 | 6 | |
| 5 ¹⁾ | 8 | 6,00 | 18 | 33 | 42 | 7,7 | M 5 | 19 | 6,2 | 3,3 | | 13 | 13 | |
| 6 | 9 | 6,75 | 20 | 36 | 46 | 8,9 | M 6 | 21 | 8,8 | 4,3 | | 1500 | 13 | 20 |
| 8 | 12 | 9,00 | 24 | 42 | 54 | 10,4 | M 8 | 25 | 16,1 | 7,1 | | 1200 | 14 | 33 |
| 10 | 14 | 10,50 | 28 | 48 | 62 | 12,9 | M 10 | 28 | 25,5 | 10,0 | | 1000 | 13 | 56 |
| 12 | 16 | 12,00 | 32 | 54 | 70 | 15,4 | M 12 | 32 | 34,5 | 13,5 | | 860 | 13 | 87 |
| 14 | 19 | 13,50 | 36 | 60 | 78 | 16,8 | M 14 | 38 | 39,5 | 17,0 | | 750 | 16 | 129 |
| 16 | 21 | 15,00 | 42 | 66 | 87 | 19,3 | M 16 | 40 | 60,5 | 21,5 | | 660 | 15 | 189 |
| 18 | 23 | 16,50 | 46 | 72 | 95 | 21,8 | M 18x1,5 | 44 | 73,0 | 26,0 | | 600 | 15 | 267 |
| 20 | 25 | 18,00 | 50 | 78 | 103 | 24,3 | M 20x1,5 | 47 | 83,0 | 31,5 | | 540 | 14 | 348 |
| 22 | 28 | 20,00 | 54 | 84 | 111 | 25,8 | M 22x1,5 | 51 | 100,0 | 38,0 | | 500 | 15 | 443 |
| 25 | 31 | 22,00 | 60 | 94 | 124 | 29,6 | M 24x2 | 57 | 118,0 | 47,0 | | 440 | 15 | 600 |
| 30 | 37 | 25,00 | 70 | 110 | 145 | 34,8 | M 30x2 | 71 | 155,0 | 64,0 | | 370 | 17 | 1030 |
| 35 | 43 | 28,00 | 80 | 125 | 165 | 37,7 | M 36x2 | 73 | 191,0 | 80,0 | | 330 | 19 | 1600 |
| 40 | 49 | 35,00 | 90 | 142 | 187 | 44,2 | M 42x2 | 78 | 235,0 | 116,0 | 290 | 16 | 2570 | |

Materials:

Housing: Stainless steel to 1.4057, Aisi 431, forged, polished size 40 turned from stainless steel to 1.4057, Aisi 431

Insert: Special high strength bronze to CuSn8

Ball: Bearing steel to 100Cr6, Aisi 52100, hardened, ground, polished, hard chrome plated on the running surface

On request: other slide pairings possible

This series is also available sealed (see page 52) or with threaded bolt (see page 53).

Cetop connections see page 54.

¹⁾ without lubrication hole

Rod Ends Series K - stainless steel - requiring maintenance

Series GIRS..R

Rod End series K with female thread regreasable through grease nipple in the housing

For use in corrosive environments

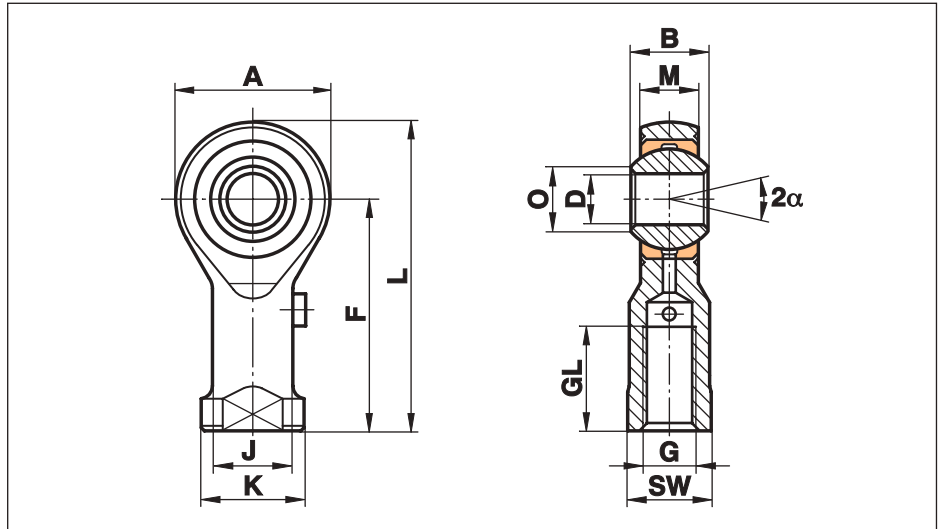

| Size (D H7) | B | M | A | F | L | K | J | O | SW | G | GL | Static load C ₀ kN | Dynamic load C kN | Limiting speed rev/min | Maximum Pivoting Angle α (°) | Weight g |
|-----------------|------|-------|----|-----|-----|------|------|------|------|---------|----|-------------------------------|-------------------|------------------------|------------------------------|----------|
| 3 ¹⁾ | 6,0 | 4,50 | 14 | 21 | 27 | 6,5 | 5,0 | 5,1 | 5,5 | M3 | 10 | 8,0 | 1,8 | | 14 | 6 |
| 5 | 8,0 | 6,00 | 18 | 27 | 36 | 11,0 | 9,0 | 7,7 | 9,0 | M5 | 10 | 11,8 | 3,3 | 1200 | 13 | 18 |
| 6 | 9,0 | 6,75 | 20 | 30 | 40 | 13,0 | 10,0 | 8,9 | 11,0 | M6 | 12 | 13,1 | 4,3 | 1500 | 13 | 27 |
| 8 | 12,0 | 9,00 | 24 | 36 | 48 | 16,0 | 12,5 | 10,4 | 13,0 | M8 | 16 | 20,7 | 7,1 | 1200 | 14 | 46 |
| 10 | 14,0 | 10,50 | 28 | 43 | 57 | 19,0 | 15,0 | 12,9 | 17,0 | M10 | 20 | 28,3 | 10,0 | 1000 | 13 | 76 |
| 12 | 16,0 | 12,00 | 32 | 50 | 66 | 22,0 | 17,5 | 15,4 | 19,0 | M12 | 22 | 34,5 | 13,5 | 860 | 13 | 115 |
| 14 | 19,0 | 13,50 | 36 | 57 | 75 | 25,0 | 20,0 | 16,8 | 22,0 | M14 | 25 | 39,5 | 17,0 | 750 | 16 | 170 |
| 16 | 21,0 | 15,00 | 42 | 64 | 85 | 27,0 | 22,0 | 19,3 | 22,0 | M16 | 28 | 60,5 | 21,5 | 660 | 15 | 230 |
| 18 | 23,0 | 16,50 | 46 | 71 | 94 | 31,0 | 25,0 | 21,8 | 27,0 | M18x1,5 | 32 | 73,0 | 26,0 | 600 | 15 | 320 |
| 20 | 25,0 | 18,00 | 50 | 77 | 102 | 34,0 | 27,5 | 24,3 | 32,0 | M20x1,5 | 33 | 83,0 | 31,5 | 540 | 14 | 415 |
| 22 | 28,0 | 20,00 | 54 | 84 | 111 | 37,0 | 30,0 | 25,8 | 32,0 | M22x1,5 | 37 | 100,0 | 38,0 | 500 | 15 | 540 |
| 25 | 31,0 | 22,00 | 60 | 94 | 124 | 42,0 | 33,5 | 29,6 | 36,0 | M24x2 | 42 | 118,0 | 47,1 | 440 | 15 | 750 |
| 30 | 37,0 | 25,00 | 70 | 110 | 145 | 50,0 | 40,0 | 34,8 | 41,0 | M30x2 | 51 | 155,0 | 64,0 | 370 | 17 | 1130 |
| 35 | 43,0 | 28,00 | 80 | 125 | 165 | 58,0 | 46,0 | 37,7 | 50,0 | M36x2 | 56 | 191,0 | 80,0 | 330 | 19 | 1600 |
| 40 | 49,0 | 35,00 | 90 | 142 | 187 | 69,0 | 57,0 | 44,2 | 60,0 | M42x2 | 60 | 235,0 | 116,0 | 290 | 16 | 2770 |

only for short-term revolutions recommended

Materials:

Housing: Stainless steel to 1.4057, Aisi 431, forged, polished
size 40 turned from stainless steel to 1.4057, Aisi 431

Insert: Special high strength bronze to CuSn8

Ball: Stainless steel to 1.4034, hardened, ground, polished

On request: other slide pairings possible

This series is also available sealed (see page 52) or with threaded bolt (see page 53).

Cetop connections see page 54.

¹⁾ without lubrication hole

Rod Ends Series K - stainless steel - requiring maintenance

Series GARS..R

Rod End series K with male thread regreasable through grease nipple in the housing

For use in corrosive environments

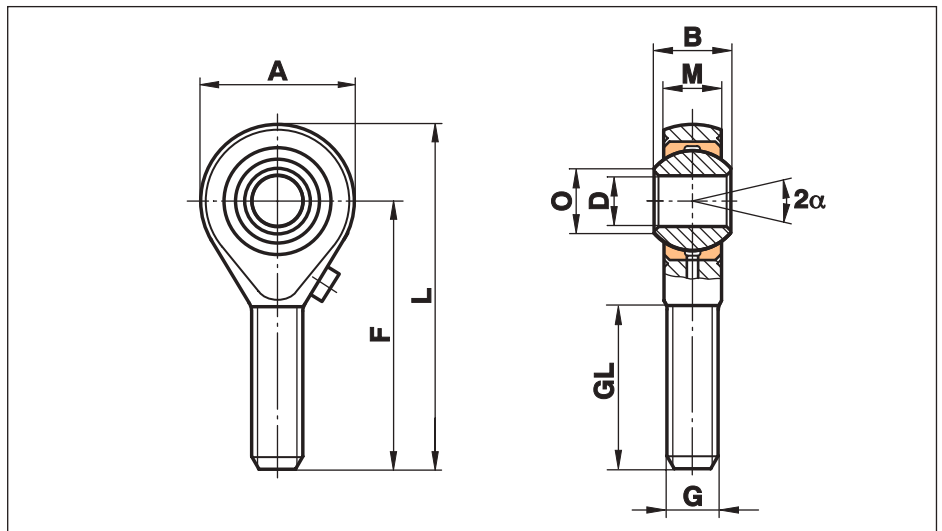

| Size (D H7) | B | M | A | F | L | O | G | GL | Static load C ₀ kN | Dynamic load C kN | Limiting speed rev/min | Maximum Pivoting Angle α (°) | Weight g |
|-----------------|----|-------|----|-----|-----|------|---------|----|-------------------------------|-------------------|------------------------|------------------------------|----------|
| 3 ¹⁾ | 6 | 4,50 | 14 | 26 | 33 | 5,1 | M3 | 15 | 7,0 | 1,8 | | 14 | 6 |
| 5 ¹⁾ | 8 | 6,00 | 18 | 33 | 42 | 7,7 | M5 | 19 | 6,2 | 3,3 | | 13 | 13 |
| 6 | 9 | 6,75 | 20 | 36 | 46 | 8,9 | M6 | 21 | 8,8 | 4,3 | 1500 | 13 | 20 |
| 8 | 12 | 9,00 | 24 | 42 | 54 | 10,4 | M8 | 25 | 16,1 | 7,1 | 1200 | 14 | 33 |
| 10 | 14 | 10,50 | 28 | 48 | 62 | 12,9 | M10 | 28 | 25,5 | 10,0 | 1000 | 13 | 56 |
| 12 | 16 | 12,00 | 32 | 54 | 70 | 15,4 | M12 | 32 | 34,5 | 13,5 | 860 | 13 | 87 |
| 14 | 19 | 13,5 | 36 | 60 | 78 | 16,8 | M14 | 38 | 39,5 | 17,0 | 750 | 16 | 129 |
| 16 | 21 | 15,00 | 42 | 66 | 87 | 19,3 | M16 | 40 | 60,5 | 21,5 | 660 | 15 | 189 |
| 18 | 23 | 16,50 | 46 | 72 | 95 | 21,8 | M18x1,5 | 44 | 73,0 | 26,0 | 600 | 15 | 267 |
| 20 | 25 | 18,00 | 50 | 78 | 103 | 24,3 | M20x1,5 | 47 | 83,0 | 31,5 | 540 | 14 | 348 |
| 22 | 28 | 20,00 | 54 | 84 | 111 | 25,8 | M22x1,5 | 51 | 100,0 | 38,0 | 500 | 15 | 443 |
| 25 | 31 | 22,00 | 60 | 94 | 124 | 29,6 | M24x2 | 57 | 118,0 | 47,0 | 440 | 15 | 600 |
| 30 | 37 | 25,00 | 70 | 110 | 145 | 34,8 | M30x2 | 71 | 155,0 | 64,0 | 370 | 17 | 1030 |
| 35 | 43 | 28,00 | 80 | 125 | 165 | 37,7 | M36x2 | 73 | 191,0 | 80,0 | 330 | 19 | 1600 |
| 40 | 49 | 35,00 | 90 | 142 | 187 | 44,2 | M42x2 | 78 | 235,0 | 116,0 | 290 | 16 | 2570 |

only for short-term revolutions recommended

Materials:

Housing: Stainless steel to 1.4057, Aisi 431, forged, polished
size 40 turned from stainless steel to 1.4057, Aisi 431

Insert: Special high strength bronze to CuSn8

Ball: Stainless steel to 1.4034, hardened, ground, polished

On request: other slide pairings possible

This series is also available sealed (see page 52) or with threaded bolt (see page 53).

Cetop connections see page 54.

¹⁾ without lubrication hole

Rod Ends Series K - Maintenance Free

Series GISW

Rod End with female thread and PTFE liner

For use at dynamic loads

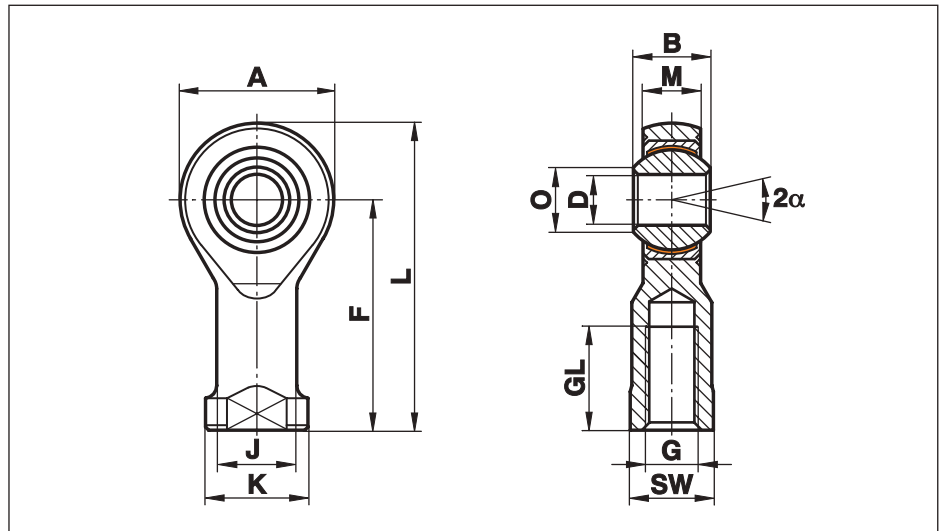

| Size (D H7) | B | M | A | F | L | K | J | O | SW | G | GL | Static load C ₀ kN | Dynamic load C kN | Limiting speed rev/min | Maximum Pivoting Angle α (°) | Weight g | |
|-------------|----|-------|-----|-----|-----|----|------|------|----|----------|----|-------------------------------|-------------------|------------------------|---|----------|-----|
| 5 | 8 | 6,00 | 18 | 27 | 36 | 11 | 9,0 | 7,7 | 9 | M 5 | 10 | 8,0 | 7,5 | 600 | only for short-term revolutions recommended | 13 | 18 |
| 6 | 9 | 6,75 | 20 | 30 | 40 | 13 | 10,0 | 8,9 | 11 | M 6 | 12 | 8,9 | 9,3 | 530 | | 13 | 27 |
| 8 | 12 | 9,00 | 24 | 36 | 48 | 16 | 12,5 | 10,4 | 13 | M 8 | 16 | 14,1 | 16,7 | 420 | | 14 | 46 |
| 10 | 14 | 10,50 | 28 | 43 | 57 | 19 | 15,0 | 12,9 | 17 | M 10 | 20 | 19,3 | 23,4 | 350 | | 13 | 76 |
| 12 | 16 | 12,00 | 32 | 50 | 66 | 22 | 17,5 | 15,4 | 19 | M 12 | 22 | 23,5 | 32,0 | 300 | | 13 | 115 |
| 14 | 19 | 13,50 | 36 | 57 | 75 | 25 | 20,0 | 16,8 | 22 | M 14 | 25 | 21,0 | 42,0 | 260 | | 16 | 170 |
| 16 | 21 | 15,00 | 42 | 64 | 85 | 27 | 22,0 | 19,3 | 22 | M 16 | 28 | 32,0 | 52,5 | 230 | | 15 | 230 |
| 18 | 23 | 16,50 | 46 | 71 | 94 | 31 | 25,0 | 21,8 | 27 | M 18x1,5 | 32 | 38,5 | 64,0 | 210 | | 15 | 320 |
| 20 | 25 | 18,00 | 50 | 77 | 102 | 34 | 27,5 | 24,3 | 32 | M 20x1,5 | 33 | 44,0 | 78,0 | 190 | | 14 | 415 |
| 22 | 28 | 20,00 | 54 | 84 | 111 | 37 | 30,0 | 25,8 | 32 | M 22x1,5 | 37 | 53,0 | 97,0 | 170 | | 15 | 540 |
| 25 | 31 | 22,00 | 60 | 94 | 124 | 42 | 33,5 | 29,6 | 36 | M 24x2 | 42 | 62,0 | 122,0 | 150 | 15 | 750 | |
| 30 | 37 | 25,00 | 70 | 110 | 145 | 51 | 40,0 | 34,8 | 41 | M 30x2 | 51 | 82,0 | 168,0 | 130 | 17 | 1130 | |
| 35 | 43 | 28,00 | 80 | 125 | 165 | 58 | 46,0 | 37,7 | 50 | M 36x2 | 56 | 101,0 | 206,0 | 110 | 19 | 1600 | |
| 40 | 49 | 35,00 | 90 | 142 | 187 | 69 | 57,0 | 44,2 | 60 | M 42x2 | 60 | 124,0 | 286,0 | 100 | 16 | 2770 | |
| 50 | 60 | 45,00 | 116 | 160 | 218 | 78 | 65,0 | 55,9 | 65 | M 48x2 | 65 | 308,0 | 485,0 | 80 | 14 | 5000 | |

Materials:

Housing: up to size 12 turned, from free-cutting steel to 9SMnPb28K, 12L13, galvanised
from size 14 forged, from heat-treated galvanised steel to C22, M1023
size 50 turned from heat-treated galvanised steel to C45, Aisi 1045

Insert: Free-cutting steel to 9SMnPb28K, 12L13, with PTFE liner bonded to the inner surface

Ball: Bearing steel to 100Cr6, Aisi 52100, hardened, ground, polished

This series is also available sealed (see page 52) or with threaded bolt (see page 53).

Cetop connections see page 54.

⚠ Please note: The dynamic load "C" of the bearing of some rod ends is in some sizes higher than the static load "C₀" of the rod end.

Rod Ends Series K - Maintenance Free

Series GASW

Rod End with male thread and PTFE liner

For use at dynamic loads

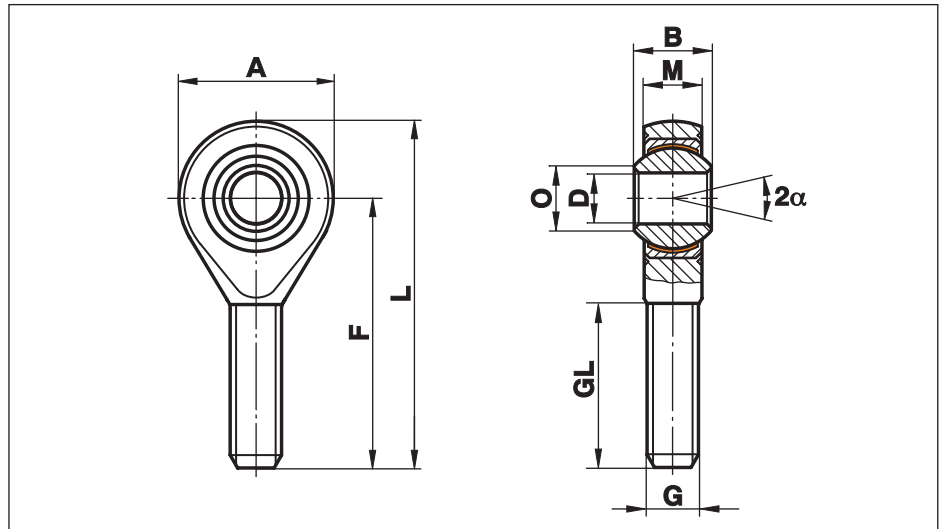

| Size (D H7) | B | M | A | F | L | O | G | GL | Static load C ₀ kN | Dynamic load C kN | Limiting speed rev/min | Maximum Pivoting Angle α (°) | Weight g |
|-------------|----|-------|-----|-----|-----|------|----------|-----|-------------------------------|-------------------|------------------------|---|----------|
| 5 | 8 | 6,00 | 18 | 33 | 42 | 7,7 | M 5 | 19 | 4,3 | 7,5 | 600 | only for short-term revolutions recommended | 13 |
| 6 | 9 | 6,75 | 20 | 36 | 46 | 8,9 | M 6 | 21 | 6,0 | 9,3 | 530 | | 13 |
| 8 | 12 | 9,00 | 24 | 42 | 54 | 10,4 | M 8 | 25 | 11,0 | 16,7 | 420 | | 14 |
| 10 | 14 | 10,50 | 28 | 48 | 62 | 12,9 | M 10 | 28 | 17,4 | 23,4 | 350 | | 13 |
| 12 | 16 | 12,00 | 32 | 54 | 70 | 15,4 | M 12 | 32 | 23,5 | 32,0 | 300 | | 13 |
| 14 | 19 | 13,50 | 36 | 60 | 78 | 16,8 | M 14 | 38 | 21,0 | 42,0 | 260 | | 16 |
| 16 | 21 | 15,00 | 42 | 66 | 87 | 19,3 | M 16 | 40 | 32,0 | 52,5 | 230 | | 15 |
| 18 | 23 | 16,50 | 46 | 72 | 95 | 21,8 | M 18x1,5 | 44 | 38,5 | 64,0 | 210 | | 15 |
| 20 | 25 | 18,00 | 50 | 78 | 103 | 24,3 | M 20x1,5 | 47 | 44,0 | 78,0 | 190 | | 14 |
| 22 | 28 | 20,00 | 54 | 84 | 111 | 25,8 | M 22x1,5 | 51 | 53,0 | 97,0 | 170 | | 15 |
| 25 | 31 | 22,00 | 60 | 94 | 124 | 29,6 | M 24x2 | 57 | 61,0 | 122,0 | 150 | | 15 |
| 30 | 37 | 25,00 | 70 | 110 | 145 | 34,8 | M 30x2 | 71 | 82,0 | 168,0 | 130 | | 17 |
| 35 | 43 | 28,00 | 80 | 125 | 165 | 37,7 | M 36x2 | 73 | 101,0 | 206,0 | 110 | 19 | |
| 40 | 49 | 35,00 | 90 | 142 | 187 | 44,2 | M 42x2 | 78 | 124,0 | 286,0 | 100 | 16 | |
| 50 | 60 | 45,00 | 116 | 185 | 243 | 55,9 | M 48x2 | 105 | 308,0 | 485,0 | 80 | 14 | |

Materials:

Housing: up to size 12 turned, from free-cutting steel to 9SMnPb28K, 12L13, galvanised
from size 14 forged, from heat-treated galvanised steel to C22, M1023
size 50 turned from heat-treated galvanised steel to C45, Aisi 1045

Insert: Free-cutting steel to 9SMnPb28K, 12L13, with PTFE liner bonded to the inner surface

Ball: Bearing steel to 100Cr6, Aisi 52100, hardened, ground, polished

This series is also available sealed (see page 52) or with threaded bolt (see page 53).

⚠ Please note: The dynamic load "C" of the bearing of some rod ends is in some sizes higher than the static load "C₀" of the rod end.

Rod Ends Series K - Heavy duty - Maintenance Free

Series GIXSW

Rod End with female thread and PTFE liner

For use at high pressure and tension loads

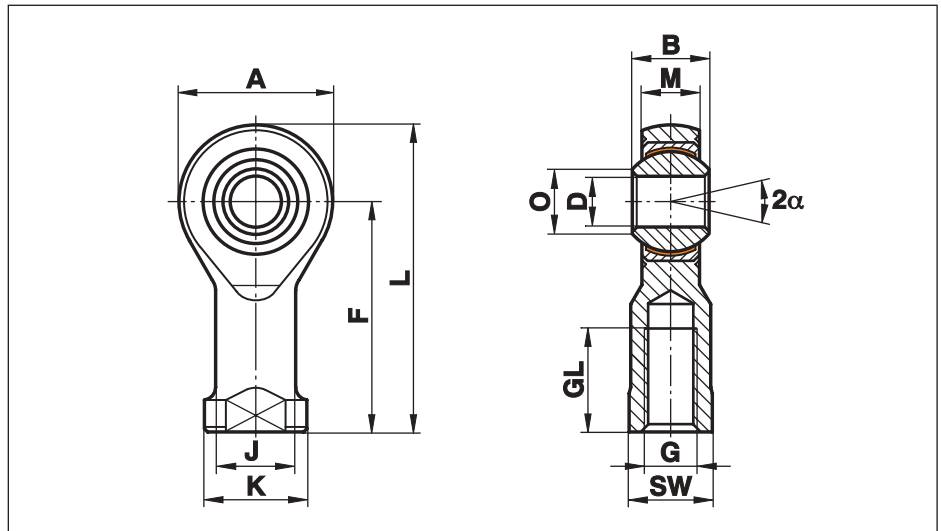

| Size (D H7) | B | M | A | F | L | K | J | O | SW | G | GL | Static load C ₀ kN | Dynamic load C kN | Limiting speed rev/min | Maximum Pivoting Angle α (°) | Weight g | |
|-------------|----|-------|----|-----|-----|----|------|------|----|----------|----|-------------------------------|-------------------|------------------------|---|----------|-----|
| 6 | 9 | 6,75 | 20 | 30 | 40 | 13 | 10,0 | 8,9 | 11 | M 6 | 12 | 16,7 | 9,3 | 530 | only for short-term revolutions recommended | 13 | 27 |
| 8 | 12 | 9,00 | 24 | 36 | 48 | 16 | 12,5 | 10,4 | 13 | M 8 | 16 | 25,5 | 16,7 | 420 | | 14 | 46 |
| 10 | 14 | 10,50 | 28 | 43 | 57 | 19 | 15,0 | 12,9 | 17 | M 10 | 20 | 34,8 | 23,4 | 350 | | 13 | 76 |
| 12 | 16 | 12,00 | 32 | 50 | 66 | 22 | 17,5 | 15,4 | 19 | M 12 | 22 | 42,0 | 32,0 | 300 | | 13 | 115 |
| 14 | 19 | 13,50 | 36 | 57 | 75 | 25 | 20,0 | 16,8 | 22 | M 14 | 25 | 57,0 | 42,0 | 260 | | 16 | 170 |
| 16 | 21 | 15,00 | 42 | 64 | 85 | 27 | 22,0 | 19,3 | 22 | M 16 | 28 | 67,5 | 52,5 | 230 | | 15 | 230 |
| 18 | 23 | 16,50 | 46 | 71 | 94 | 31 | 25,0 | 21,8 | 27 | M 18x1,5 | 32 | 81,5 | 64,0 | 210 | | 15 | 320 |
| 20 | 25 | 18,00 | 50 | 77 | 102 | 34 | 27,5 | 24,3 | 32 | M 20x1,5 | 33 | 93,5 | 78,0 | 190 | | 14 | 415 |
| 22 | 28 | 20,00 | 54 | 84 | 111 | 37 | 30,0 | 25,8 | 32 | M 22x1,5 | 37 | 114,0 | 97,0 | 170 | | 15 | 540 |
| 25 | 31 | 22,00 | 60 | 94 | 124 | 42 | 33,5 | 29,6 | 36 | M 24x2 | 42 | 135,0 | 122,0 | 150 | | 15 | 750 |
| 30 | 37 | 25,00 | 70 | 110 | 145 | 51 | 40,0 | 34,8 | 41 | M 30x2 | 51 | 184,0 | 168,0 | 130 | 17 | 1130 | |
| 35 | 43 | 28,00 | 80 | 125 | 165 | 58 | 46,0 | 37,7 | 50 | M 36x2 | 56 | 230,0 | 205,0 | 110 | 19 | 1600 | |
| 40 | 49 | 35,00 | 90 | 142 | 187 | 69 | 57,0 | 44,2 | 60 | M 42x2 | 60 | 270,0 | 286,0 | 100 | 16 | 2770 | |

Materials:

Housing: Heat-treated steel to 42CrMo4, Aisi 4140, forged, galvanised

Insert: Free-cutting steel to 9SMnPb28K, 12L13, galvanised, with PTFE liner bonded to the inner surface

Ball: Bearing steel to 100Cr6, Aisi 52100, hardened, ground, polished

This series is also available sealed (see page 52) or with threaded bolt (see page 53).

Cetop connections see page 54.

Rod Ends Series K - Heavy duty - Maintenance Free

Series GAXSW

Rod End with male thread and PTFE liner

For use at high pressure and tension loads

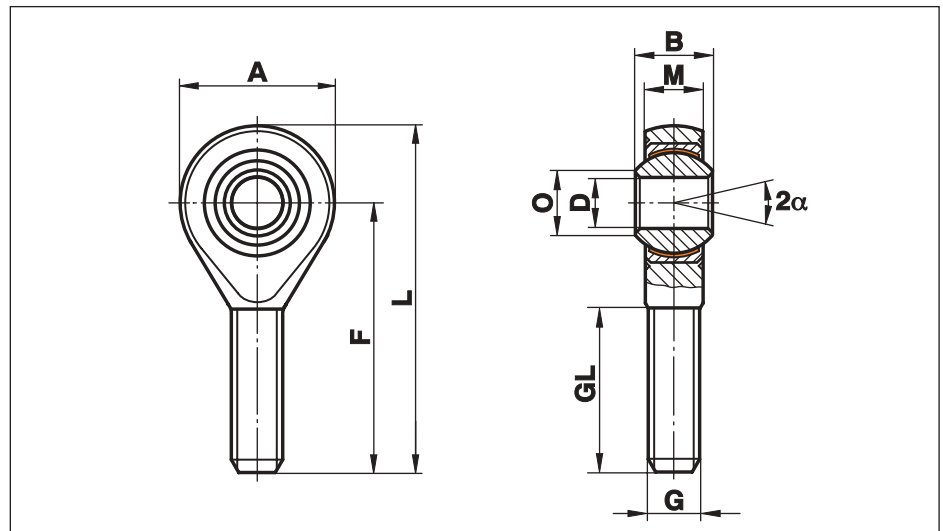

| Size (D H7) | B | M | A | F | L | O | G | GL | Static load C ₀ kN | Dynamic load C kN | Limiting speed rev/min | Maximum Pivoting Angle α (°) | Weight g |
|-------------|----|-------|----|-----|-----|------|----------|----|-------------------------------|-------------------|------------------------|------------------------------|----------|
| 6 | 9 | 6,75 | 20 | 36 | 46 | 8,9 | M 6 | 21 | 9,8 | 9,3 | 530 | 13 | 20 |
| 8 | 12 | 9,00 | 24 | 42 | 54 | 10,4 | M 8 | 25 | 19,5 | 16,7 | 420 | 14 | 33 |
| 10 | 14 | 10,50 | 28 | 48 | 62 | 12,9 | M 10 | 28 | 31,4 | 23,4 | 350 | 13 | 56 |
| 12 | 16 | 12,00 | 32 | 54 | 70 | 15,4 | M 12 | 32 | 42,0 | 32,0 | 300 | 13 | 87 |
| 14 | 19 | 13,50 | 36 | 60 | 78 | 16,8 | M 14 | 38 | 57,0 | 42,0 | 260 | 16 | 129 |
| 16 | 21 | 15,00 | 42 | 66 | 87 | 19,3 | M 16 | 40 | 67,0 | 52,5 | 230 | 15 | 189 |
| 18 | 23 | 16,50 | 46 | 72 | 95 | 21,8 | M 18x1,5 | 44 | 81,5 | 64,0 | 210 | 15 | 267 |
| 20 | 25 | 18,00 | 50 | 78 | 103 | 24,3 | M 20x1,5 | 47 | 93,5 | 78,0 | 190 | 14 | 348 |
| 22 | 28 | 20,00 | 54 | 84 | 111 | 25,8 | M 22x1,5 | 51 | 114,0 | 97,0 | 170 | 15 | 443 |
| 25 | 31 | 22,00 | 60 | 94 | 124 | 29,6 | M 24x2 | 57 | 135,0 | 122,0 | 150 | 15 | 600 |
| 30 | 37 | 25,00 | 70 | 110 | 145 | 34,8 | M 30x2 | 71 | 184,0 | 168,0 | 130 | 17 | 1030 |
| 35 | 43 | 28,00 | 80 | 125 | 165 | 37,7 | M 36x2 | 73 | 230,0 | 205,0 | 110 | 19 | 1600 |

Materials:

Housing: Heat-treated steel to 42CrMo4, Aisi 4140, forged, galvanised

Insert: Free-cutting steel to 9SMnPb28K, 12L13, galvanised, with PTFE liner bonded to the inner surface

Ball: Bearing steel to 100Cr6, Aisi 52100, hardened, ground, polished

This series is also available sealed (see page 52) or with threaded bolt (see page 53).

Cetop connections see page 54.

Rod Ends Series K - Stainless, Maintenance Free

Series GIRSW

Rod End with female thread and PTFE liner

For use at high dynamic pressure and tension loads in corrosive environments

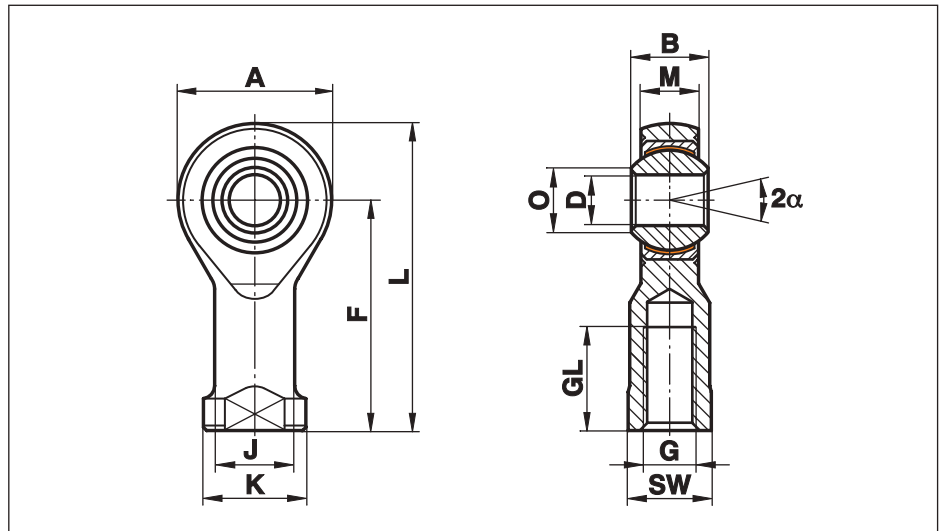

| Size (D H7) | B | M | A | F | L | K | J | O | SW | G | GL | Static load C ₀ kN | Dynamic load C kN | Limiting speed rev/min | Maximum Pivoting Angle α (°) | Weight g | |
|-----------------|----|-------|----|-----|-----|------|------|------|----|----------|----|-------------------------------|-------------------|---|------------------------------|----------|------|
| 4 ¹⁾ | 7 | 5,25 | 14 | 24 | 31 | 9,5 | 7,8 | 6,5 | 8 | M 4 | 12 | 2,5 | 5,1 | only for short-term revolutions recommended | 14 | 11 | |
| 5 | 8 | 6,00 | 18 | 27 | 36 | 11,0 | 9,0 | 7,7 | 9 | M 5 | 10 | 11,8 | 7,5 | | 600 | 13 | 18 |
| 6 | 9 | 6,75 | 20 | 30 | 40 | 13,0 | 10,0 | 8,9 | 11 | M 6 | 12 | 13,1 | 9,3 | | 530 | 13 | 27 |
| 8 | 12 | 9,00 | 24 | 36 | 48 | 16,0 | 12,5 | 10,4 | 13 | M 8 | 16 | 20,7 | 16,7 | | 420 | 14 | 46 |
| 10 | 14 | 10,50 | 28 | 43 | 57 | 19,0 | 15,0 | 12,9 | 17 | M 10 | 20 | 28,3 | 23,4 | | 350 | 13 | 76 |
| 12 | 16 | 12,00 | 32 | 50 | 66 | 22,0 | 17,5 | 15,4 | 19 | M 12 | 22 | 34,5 | 32,0 | | 300 | 13 | 115 |
| 14 | 19 | 13,50 | 36 | 57 | 75 | 25,0 | 20,0 | 16,8 | 22 | M 14 | 25 | 39,5 | 42,0 | | 260 | 16 | 170 |
| 16 | 21 | 15,00 | 42 | 64 | 85 | 27,0 | 22,0 | 19,3 | 22 | M 16 | 28 | 60,5 | 52,5 | | 230 | 15 | 230 |
| 18 | 23 | 16,50 | 46 | 71 | 94 | 31,0 | 25,0 | 21,8 | 27 | M 18x1,5 | 32 | 73,0 | 64,0 | | 210 | 15 | 320 |
| 20 | 25 | 18,00 | 50 | 77 | 102 | 34,0 | 27,5 | 24,3 | 32 | M 20x1,5 | 33 | 83,0 | 78,0 | | 190 | 14 | 415 |
| 22 | 28 | 20,00 | 54 | 84 | 111 | 37,0 | 30,0 | 25,8 | 32 | M 22x1,5 | 37 | 100,0 | 97,0 | | 170 | 15 | 540 |
| 25 | 31 | 22,00 | 60 | 94 | 124 | 42,0 | 33,5 | 29,6 | 36 | M 24x2 | 42 | 118,0 | 122,0 | | 150 | 15 | 750 |
| 30 | 37 | 25,00 | 70 | 110 | 145 | 50,0 | 40,0 | 34,8 | 41 | M 30x2 | 51 | 155,0 | 168,0 | | 130 | 17 | 1130 |
| 35 | 43 | 28,00 | 80 | 125 | 165 | 58,0 | 46,0 | 37,7 | 50 | M 36x2 | 56 | 191,0 | 206,0 | | 110 | 19 | 1600 |
| 40 | 49 | 35,00 | 90 | 142 | 187 | 69,0 | 57,0 | 44,2 | 60 | M 42x2 | 60 | 235,0 | 286,0 | | 100 | 16 | 2770 |

Materials:

Housing: Stainless steel to 1.4057, Aisi 431, forged, polished
size 40 turned from stainless steel to 1.4057, Aisi 431

Insert: Special high strength bronze to CuSn8 with PTFE liner bonded to the inner surface

Ball: Bearing steel to 100Cr6, Aisi 52100, hardened, ground, polished, hard chrome plated on the running surface

This series is also available sealed (see page 52) or with threaded bolt (see page 53).

Cetop connections see page 54.

¹⁾ Size 4 on request. Housing turned from stainless steel to 1.4305, Aisi 303

! Please note: The dynamic load "C" of the bearing of some rod ends is in some sizes higher than the static load "C₀" of the rod end.

Rod Ends Series K - Stainless, Maintenance Free

Series GARSW

Rod End with male thread and PTFE liner

For use at high dynamic pressure and tension loads in corrosive environments

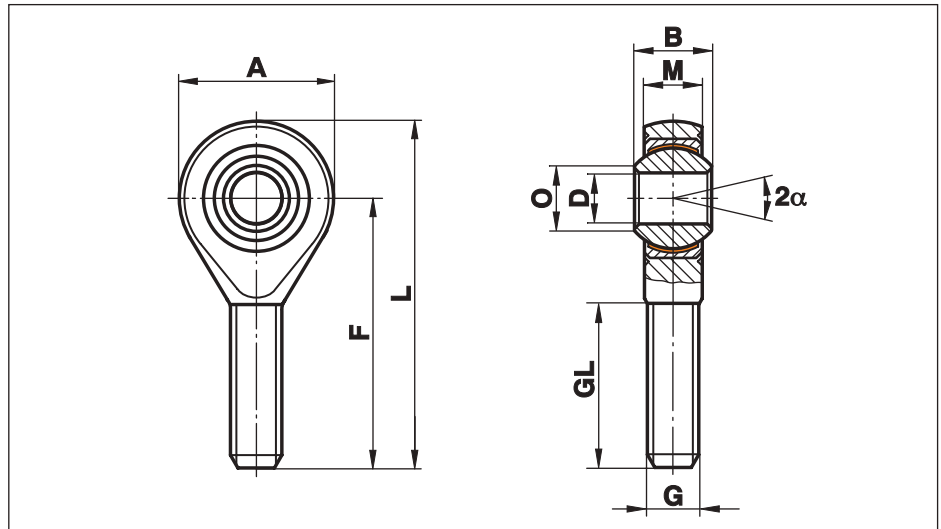

| Size (D H7) | B | M | A | F | L | O | G | GL | Static load C ₀ kN | Dynamic load C kN | Limiting speed rev/min | Maximum Pivoting Angle α (°) | Weight g | |
|-----------------|----|-------|----|-----|-----|------|----------|----|-------------------------------|-------------------|---|------------------------------|----------|------|
| 4 ¹⁾ | 7 | 5,25 | 14 | 30 | 37 | 6,5 | M 4 | 19 | 2,5 | 5,1 | only for short-term revolutions recommended | 14 | 9 | |
| 5 | 8 | 6,00 | 18 | 33 | 42 | 7,7 | M 5 | 19 | 6,2 | 7,5 | | 600 | 13 | 13 |
| 6 | 9 | 6,75 | 20 | 36 | 46 | 8,9 | M 6 | 21 | 8,8 | 9,3 | | 530 | 13 | 20 |
| 8 | 12 | 9,00 | 24 | 42 | 54 | 10,4 | M 8 | 25 | 16,1 | 16,7 | | 420 | 14 | 33 |
| 10 | 14 | 10,50 | 28 | 48 | 62 | 12,9 | M 10 | 28 | 25,5 | 23,4 | | 350 | 13 | 56 |
| 12 | 16 | 12,00 | 32 | 54 | 70 | 15,4 | M 12 | 32 | 34,5 | 32,0 | | 300 | 13 | 87 |
| 14 | 19 | 13,50 | 36 | 60 | 78 | 16,8 | M 14 | 38 | 39,5 | 42,0 | | 260 | 16 | 129 |
| 16 | 21 | 15,00 | 42 | 66 | 87 | 19,3 | M 16 | 40 | 60,5 | 52,5 | | 230 | 15 | 189 |
| 18 | 23 | 16,50 | 46 | 72 | 95 | 21,8 | M 18x1,5 | 44 | 73,0 | 64,0 | | 210 | 15 | 267 |
| 20 | 25 | 18,00 | 50 | 78 | 103 | 24,3 | M 20x1,5 | 47 | 83,0 | 78,0 | | 190 | 14 | 348 |
| 22 | 28 | 20,00 | 54 | 84 | 111 | 25,8 | M 22x1,5 | 51 | 100,0 | 97,0 | | 170 | 15 | 443 |
| 25 | 31 | 22,00 | 60 | 94 | 124 | 29,6 | M 24x2 | 57 | 118,0 | 122,0 | | 150 | 15 | 600 |
| 30 | 37 | 25,00 | 70 | 110 | 145 | 34,8 | M 30x2 | 71 | 155,0 | 168,0 | | 130 | 17 | 1030 |
| 35 | 43 | 28,00 | 80 | 125 | 165 | 37,7 | M 36x2 | 73 | 191,0 | 206,0 | 110 | 19 | 1600 | |
| 40 | 49 | 35,00 | 90 | 142 | 187 | 44,2 | M 42x2 | 78 | 235,0 | 286,0 | 100 | 16 | 2570 | |

Materials:

Housing: Stainless steel to 1.4057, Aisi 431, forged, polished
size 40 turned from stainless steel to 1.4057, Aisi 431

Insert: Special high strength bronze to CuSn8 with PTFE liner bonded to the inner surface

Ball: Bearing steel to 100Cr6, Aisi 52100, hardened, ground, polished, hard chrome plated on the running surface

This series is also available sealed (see page 52) or with threaded bolt (see page 53).

¹⁾ Size 4 on request. Housing turned from stainless steel to 1.4305, Aisi 303

⚠ Please note: The dynamic load "C" of the bearing of some rod ends is in some sizes higher than the static load "C₀" of the rod end.

Rod Ends Series K - Stainless, Maintenance Free

Series

GIRSW..R

Rod End with female thread and PTFE liner

For use at high dynamic pressure and tension loads in corrosive environments

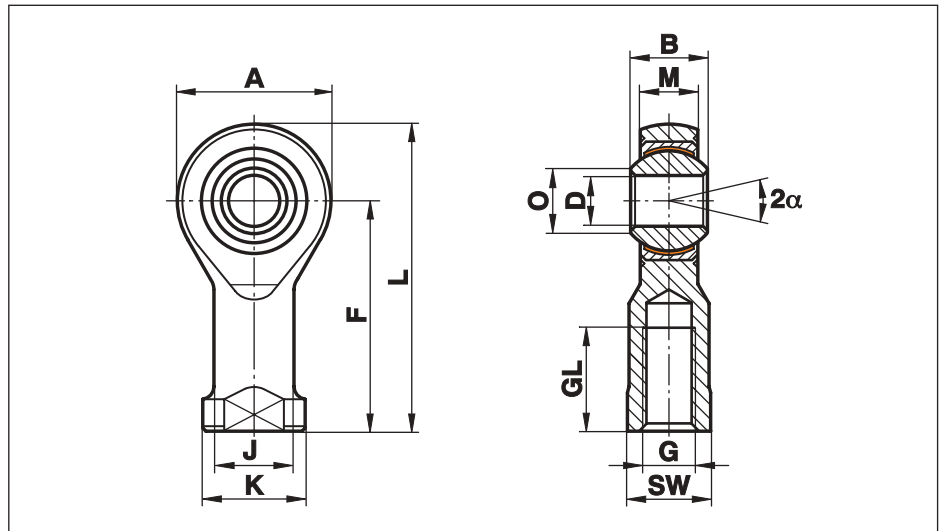

| Size (D H7) | B | M | A | F | L | K | J | O | SW | G | GL | Static load C ₀ kN | Dynamic load C kN | Limiting speed rev/min | Maximum Pivoting Angle α (°) | Weight g | |
|-----------------|----|-------|----|-----|-----|------|------|------|----|----------|----|-------------------------------|-------------------|---|------------------------------|----------|------|
| 4 ¹⁾ | 7 | 5,25 | 14 | 24 | 31 | 9,5 | 7,8 | 6,5 | 8 | M 4 | 12 | 2,5 | 5,1 | only for short-term revolutions recommended | 14 | 11 | |
| 5 | 8 | 6,00 | 18 | 27 | 36 | 11,0 | 9,0 | 7,7 | 9 | M 5 | 10 | 11,8 | 7,5 | | 600 | 13 | 18 |
| 6 | 9 | 6,75 | 20 | 30 | 40 | 13,0 | 10,0 | 8,9 | 11 | M 6 | 12 | 13,1 | 9,3 | | 530 | 13 | 27 |
| 8 | 12 | 9,00 | 24 | 36 | 48 | 16,0 | 12,5 | 10,4 | 13 | M 8 | 16 | 20,7 | 16,7 | | 420 | 14 | 46 |
| 10 | 14 | 10,50 | 28 | 43 | 57 | 19,0 | 15,0 | 12,9 | 17 | M 10 | 20 | 28,3 | 23,4 | | 350 | 13 | 76 |
| 12 | 16 | 12,00 | 32 | 50 | 66 | 22,0 | 17,5 | 15,4 | 19 | M 12 | 22 | 34,5 | 32,0 | | 300 | 13 | 115 |
| 14 | 19 | 13,50 | 36 | 57 | 75 | 25,0 | 20,0 | 16,8 | 22 | M 14 | 25 | 39,5 | 42,0 | | 260 | 16 | 170 |
| 16 | 21 | 15,00 | 42 | 64 | 85 | 27,0 | 22,0 | 19,3 | 22 | M 16 | 28 | 60,5 | 52,5 | | 230 | 15 | 230 |
| 18 | 23 | 16,50 | 46 | 71 | 94 | 31,0 | 25,0 | 21,8 | 27 | M 18x1,5 | 32 | 73,0 | 64,0 | | 210 | 15 | 320 |
| 20 | 25 | 18,00 | 50 | 77 | 102 | 34,0 | 27,5 | 24,3 | 32 | M 20x1,5 | 33 | 83,0 | 78,0 | | 190 | 14 | 415 |
| 22 | 28 | 20,00 | 54 | 84 | 111 | 37,0 | 30,0 | 25,8 | 32 | M 22x1,5 | 37 | 100,0 | 97,0 | | 170 | 15 | 540 |
| 25 | 31 | 22,00 | 60 | 94 | 124 | 42,0 | 33,5 | 29,6 | 36 | M 24x2 | 42 | 118,0 | 122,0 | | 150 | 15 | 750 |
| 30 | 37 | 25,00 | 70 | 110 | 145 | 50,0 | 40,0 | 34,8 | 41 | M 30x2 | 51 | 155,0 | 168,0 | | 130 | 17 | 1130 |
| 35 | 43 | 28,00 | 80 | 125 | 165 | 58,0 | 46,0 | 37,7 | 50 | M 36x2 | 56 | 191,0 | 206,0 | | 110 | 19 | 1600 |
| 40 | 49 | 35,00 | 90 | 142 | 187 | 69,0 | 57,0 | 44,2 | 60 | M 42x2 | 60 | 235,0 | 286,0 | | 100 | 16 | 2770 |

Materials:

Housing: Stainless steel to 1.4057, Aisi 431, forged, polished
size 40 turned from stainless steel to 1.4057, Aisi 431

Insert: Special high strength bronze to CuSn8 with PTFE liner bonded to the inner surface

Ball: Stainless steel 1.4034, hardened, ground, polished

This series is also available sealed (see page 52) or with threaded bolt (see page 53).

Cetop connections see page 54.

¹⁾ Size 4 on request. Housing turned from stainless steel to 1.4305, Aisi 303

⚠ Please note: The dynamic load "C" of the bearing of some rod ends is in some sizes higher than the static load "C₀" of the rod end.

Rod Ends Series K - Stainless, Maintenance Free

Series

GARSW..R

Rod End with male thread and PTFE liner

For use at high dynamic pressure and tension loads in corrosive environments

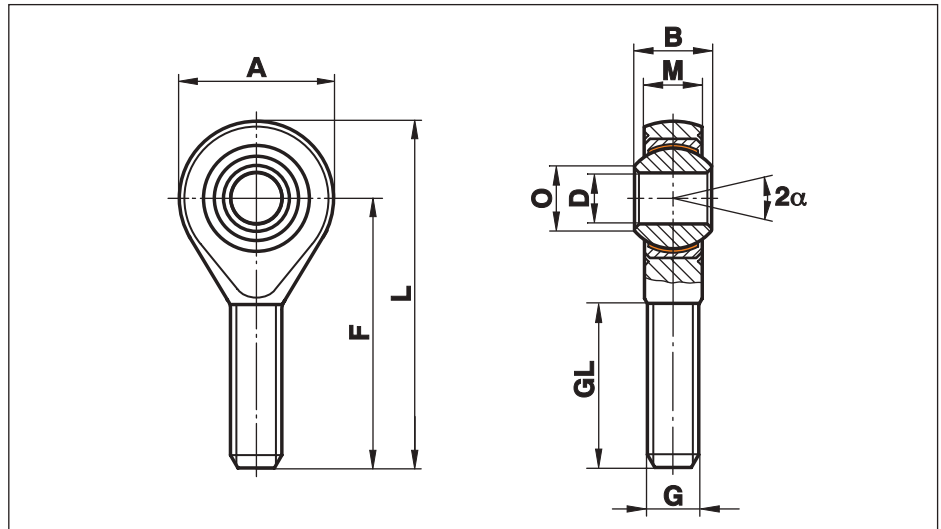

| Size (D H7) | B | M | A | F | L | O | G | GL | Static load C ₀ kN | Dynamic load C kN | Limiting speed rev/min | Maximum Pivoting Angle α (°) | Weight g |
|-----------------|----|-------|----|-----|-----|------|----------|----|-------------------------------|-------------------|------------------------|------------------------------|----------|
| 4 ¹⁾ | 7 | 5,25 | 14 | 30 | 37 | 6,5 | M 4 | 19 | 2,5 | 5,1 | | 14 | 9 |
| 5 | 8 | 6,00 | 18 | 33 | 42 | 7,7 | M 5 | 19 | 6,2 | 7,5 | 600 | 13 | 13 |
| 6 | 9 | 6,75 | 20 | 36 | 46 | 8,9 | M 6 | 21 | 8,8 | 9,3 | 530 | 13 | 20 |
| 8 | 12 | 9,00 | 24 | 42 | 54 | 10,4 | M 8 | 25 | 16,1 | 16,7 | 420 | 14 | 33 |
| 10 | 14 | 10,50 | 28 | 48 | 62 | 12,9 | M 10 | 28 | 25,5 | 23,4 | 350 | 13 | 56 |
| 12 | 16 | 12,00 | 32 | 54 | 70 | 15,4 | M 12 | 32 | 34,5 | 32,0 | 300 | 13 | 87 |
| 14 | 19 | 13,50 | 36 | 60 | 78 | 16,8 | M 14 | 38 | 39,5 | 42,0 | 260 | 16 | 129 |
| 16 | 21 | 15,00 | 42 | 66 | 87 | 19,3 | M 16 | 40 | 60,5 | 52,5 | 230 | 15 | 189 |
| 18 | 23 | 16,50 | 46 | 72 | 95 | 21,8 | M 18x1,5 | 44 | 73,0 | 64,0 | 210 | 15 | 267 |
| 20 | 25 | 18,00 | 50 | 78 | 103 | 24,3 | M 20x1,5 | 47 | 83,0 | 78,0 | 190 | 14 | 348 |
| 22 | 28 | 20,00 | 54 | 84 | 111 | 25,8 | M 22x1,5 | 51 | 100,0 | 97,0 | 170 | 15 | 443 |
| 25 | 31 | 22,00 | 60 | 94 | 124 | 29,6 | M 24x2 | 57 | 118,0 | 122,0 | 150 | 15 | 600 |
| 30 | 37 | 25,00 | 70 | 110 | 145 | 34,8 | M 30x2 | 71 | 155,0 | 168,0 | 130 | 17 | 1030 |
| 35 | 43 | 28,00 | 80 | 125 | 165 | 37,7 | M 36x2 | 73 | 191,0 | 206,0 | 110 | 19 | 1600 |
| 40 | 49 | 35,00 | 90 | 142 | 187 | 44,2 | M 42x2 | 78 | 235,0 | 286,0 | 100 | 16 | 2570 |

only for short-term revolutions recommended

Materials:

Housing: Stainless steel to 1.4057, Aisi 431, forged, polished
size 40 turned from stainless steel to 1.4057, Aisi 431

Insert: Special high strength bronze to CuSn8 with PTFE liner bonded to the inner surface

Ball: Stainless steel 1.4034, hardened, ground, polished

This series is also available sealed (see page 52) or with threaded bolt (see page 53).

Cetop connections see page 54.

¹⁾ Size 4 on request. Housing turned from stainless steel to 1.4305, Aisi 303

⚠ Please note: The dynamic load "C" of the bearing of some rod ends is in some sizes higher than the static load "C₀" of the rod end.

Rod Ends Series K - Stainless, Maintenance Free

Series

GIRSW..RR

Rod End with female thread and PTFE liner

For use at high dynamic pressure and tension loads in corrosive environments

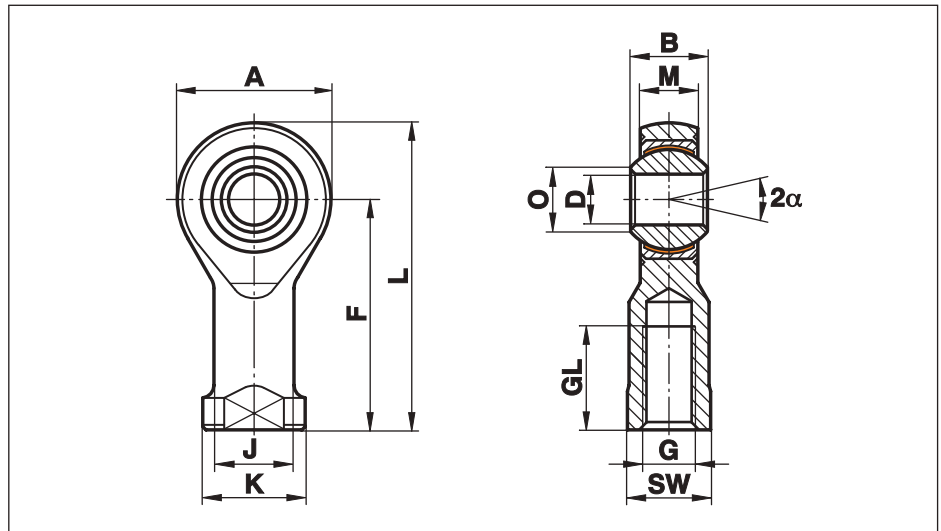

| Size (D H7) | B | M | A | F | L | K | J | O | SW | G | GL | Static load C ₀ kN | Dynamic load C kN | Limiting speed rev/min | Maximum Pivoting Angle α (°) | Weight g | |
|-----------------|----|-------|----|-----|-----|------|------|------|----|----------|----|-------------------------------|-------------------|---|------------------------------|----------|------|
| 4 ¹⁾ | 7 | 5,25 | 14 | 24 | 31 | 9,5 | 7,8 | 6,5 | 8 | M 4 | 12 | 2,5 | 5,1 | only for short-term revolutions recommended | 14 | 11 | |
| 5 | 8 | 6,00 | 18 | 27 | 36 | 11,0 | 9,0 | 7,7 | 9 | M 5 | 10 | 11,8 | 7,5 | | 600 | 13 | 18 |
| 6 | 9 | 6,75 | 20 | 30 | 40 | 13,0 | 10,0 | 8,9 | 11 | M 6 | 12 | 13,1 | 9,3 | | 530 | 13 | 27 |
| 8 | 12 | 9,00 | 24 | 36 | 48 | 16,0 | 12,5 | 10,4 | 13 | M 8 | 16 | 20,7 | 16,7 | | 420 | 14 | 46 |
| 10 | 14 | 10,50 | 28 | 43 | 57 | 19,0 | 15,0 | 12,9 | 17 | M 10 | 20 | 28,3 | 23,4 | | 350 | 13 | 76 |
| 12 | 16 | 12,00 | 32 | 50 | 66 | 22,0 | 17,5 | 15,4 | 19 | M 12 | 22 | 34,5 | 32,0 | | 300 | 13 | 115 |
| 14 | 19 | 13,50 | 36 | 57 | 75 | 25,0 | 20,0 | 16,8 | 22 | M 14 | 25 | 39,5 | 42,0 | | 260 | 16 | 170 |
| 16 | 21 | 15,00 | 42 | 64 | 85 | 27,0 | 22,0 | 19,3 | 22 | M 16 | 28 | 60,5 | 52,5 | | 230 | 15 | 230 |
| 18 | 23 | 16,50 | 46 | 71 | 94 | 31,0 | 25,0 | 21,8 | 27 | M 18x1,5 | 32 | 73,0 | 64,0 | | 210 | 15 | 320 |
| 20 | 25 | 18,00 | 50 | 77 | 102 | 34,0 | 27,5 | 24,3 | 32 | M 20x1,5 | 33 | 83,0 | 78,0 | | 190 | 14 | 415 |
| 22 | 28 | 20,00 | 54 | 84 | 111 | 37,0 | 30,0 | 25,8 | 32 | M 22x1,5 | 37 | 100,0 | 97,0 | | 170 | 15 | 540 |
| 25 | 31 | 22,00 | 60 | 94 | 124 | 42,0 | 33,5 | 29,6 | 36 | M 24x2 | 42 | 118,0 | 122,0 | | 150 | 15 | 750 |
| 30 | 37 | 25,00 | 70 | 110 | 145 | 50,0 | 40,0 | 34,8 | 41 | M 30x2 | 51 | 155,0 | 168,0 | | 130 | 17 | 1130 |
| 35 | 43 | 28,00 | 80 | 125 | 165 | 58,0 | 46,0 | 37,7 | 50 | M 36x2 | 56 | 191,0 | 206,0 | | 110 | 19 | 1600 |
| 40 | 49 | 35,00 | 90 | 142 | 187 | 69,0 | 57,0 | 44,2 | 60 | M 42x2 | 60 | 235,0 | 286,0 | | 100 | 16 | 2770 |

Materials:

Housing: Stainless steel to 1.4057, Aisi 431, forged, polished
size 40 turned from stainless steel to 1.4057, Aisi 431

Insert: Stainless steel 1.4571 with PTFE liner bonded to the inner surface

Ball: Stainless steel 1.4034, hardened, ground, polished

This series is also available sealed (see page 52) or with threaded bolt (see page 53).

Cetop connections see page 54.

¹⁾ Size 4 on request. Housing turned from stainless steel to 1.4305, Aisi 303

⚠ Please note: The dynamic load "C" of the bearing of some rod ends is in some sizes higher than the static load "C₀" of the rod end.

Rod Ends Series K - Stainless, Maintenance Free

Series

GARSW..RR

Rod End with male thread and PTFE liner

For use at high dynamic pressure and tension loads in corrosive environments

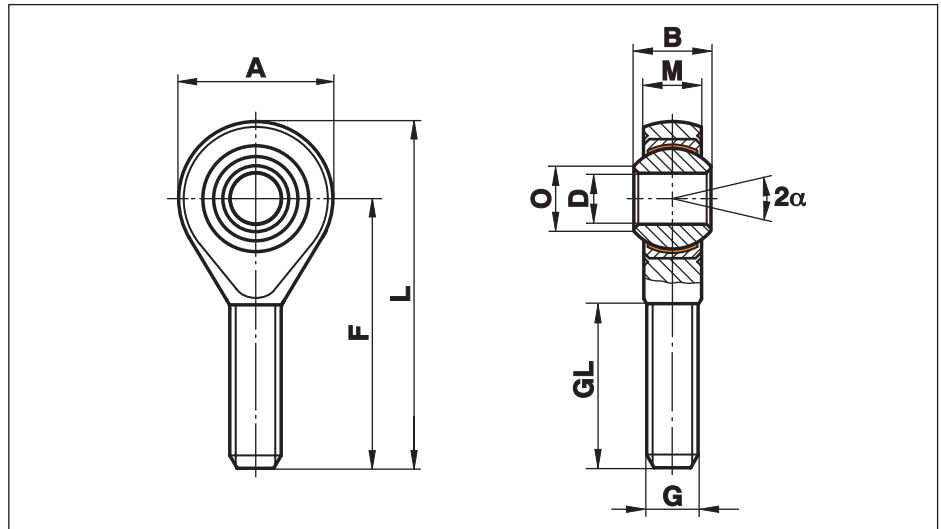

| Size (D H7) | B | M | A | F | L | O | G | GL | Static load C ₀ kN | Dynamic load C kN | Limiting speed rev/min | Maximum Pivoting Angle α (°) | Weight g |
|-----------------|----|-------|----|-----|-----|------|----------|----|-------------------------------|-------------------|------------------------|------------------------------|----------|
| 4 ¹⁾ | 7 | 5,25 | 14 | 30 | 37 | 6,5 | M 4 | 19 | 2,5 | 5,1 | | 14 | 9 |
| 5 | 8 | 6,00 | 18 | 33 | 42 | 7,7 | M 5 | 19 | 6,2 | 7,5 | 600 | 13 | 13 |
| 6 | 9 | 6,75 | 20 | 36 | 46 | 8,9 | M 6 | 21 | 8,8 | 9,3 | 530 | 13 | 20 |
| 8 | 12 | 9,00 | 24 | 42 | 54 | 10,4 | M 8 | 25 | 16,1 | 16,7 | 420 | 14 | 33 |
| 10 | 14 | 10,50 | 28 | 48 | 62 | 12,9 | M 10 | 28 | 25,5 | 23,4 | 350 | 13 | 56 |
| 12 | 16 | 12,00 | 32 | 54 | 70 | 15,4 | M 12 | 32 | 34,5 | 32,0 | 300 | 13 | 87 |
| 14 | 19 | 13,50 | 36 | 60 | 78 | 16,8 | M 14 | 38 | 39,5 | 42,0 | 260 | 16 | 129 |
| 16 | 21 | 15,00 | 42 | 66 | 87 | 19,3 | M 16 | 40 | 60,5 | 52,5 | 230 | 15 | 189 |
| 18 | 23 | 16,50 | 46 | 72 | 95 | 21,8 | M 18x1,5 | 44 | 73,0 | 64,0 | 210 | 15 | 267 |
| 20 | 25 | 18,00 | 50 | 78 | 103 | 24,3 | M 20x1,5 | 47 | 83,0 | 78,0 | 190 | 14 | 348 |
| 22 | 28 | 20,00 | 54 | 84 | 111 | 25,8 | M 22x1,5 | 51 | 100,0 | 97,0 | 170 | 15 | 443 |
| 25 | 31 | 22,00 | 60 | 94 | 124 | 29,6 | M 24x2 | 57 | 118,0 | 122,0 | 150 | 15 | 600 |
| 30 | 37 | 25,00 | 70 | 110 | 145 | 34,8 | M 30x2 | 71 | 155,0 | 168,0 | 130 | 17 | 1030 |
| 35 | 43 | 28,00 | 80 | 125 | 165 | 37,7 | M 36x2 | 73 | 191,0 | 206,0 | 110 | 19 | 1600 |
| 40 | 49 | 35,00 | 90 | 142 | 187 | 44,2 | M 42x2 | 78 | 235,0 | 286,0 | 100 | 16 | 2570 |

only for short-term revolutions recommended

Materials:

Housing: Stainless steel to 1.4057, Aisi 431, forged, polished
size 40 turned from stainless steel to 1.4057, Aisi 431

Insert: Stainless steel 1.4571 with PTFE liner bonded to the inner surface

Ball: Stainless steel 1.4034, hardened, ground, polished

This series is also available sealed (see page 52) or with threaded bolt (see page 53).

¹⁾ Size 4 on request. Housing turned from stainless steel to 1.4305, Aisi 303

⚠ Please note: The dynamic load "C" of the bearing of some rod ends is in some sizes higher than the static load "C₀" of the rod end.

Rod Ends Series K - Stainless, Maintenance Free

Series

GIRSW..RR.316

Rod Ends with female thread and PTFE liner

For use at high dynamic pressure and tension loads in corrosive environments

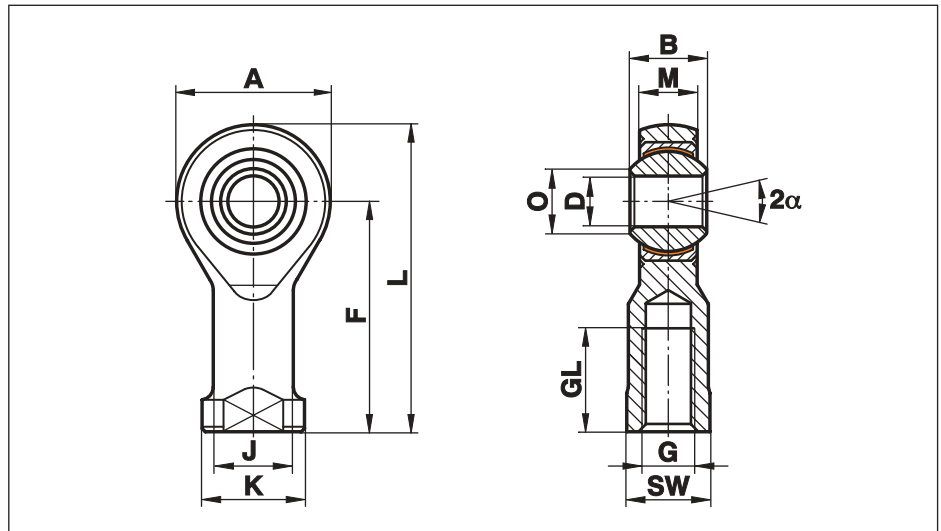

| Size (D H7) | B | M | A | F | L | K | J | O | SW | G | GL | Static load C ₀ kN | Dynamic load C kN | Limiting speed rev/min | Maximum Pivoting Angle α (°) | Weight g | |
|-----------------|----|-------|----|-----|-----|------|------|------|----|----------|----|-------------------------------|-------------------|---|------------------------------|----------|------|
| 4 ¹⁾ | 7 | 5,25 | 14 | 24 | 31 | 9,5 | 7,8 | 6,5 | 8 | M 4 | 12 | 2,5 | 5,1 | only for short-term revolutions recommended | 14 | 11 | |
| 5 | 8 | 6,00 | 18 | 27 | 36 | 11,0 | 9,0 | 7,7 | 9 | M 5 | 10 | 11,8 | 7,5 | | 600 | 13 | 18 |
| 6 | 9 | 6,75 | 20 | 30 | 40 | 13,0 | 10,0 | 8,9 | 11 | M 6 | 12 | 13,1 | 9,3 | | 530 | 13 | 27 |
| 8 | 12 | 9,00 | 24 | 36 | 48 | 16,0 | 12,5 | 10,4 | 13 | M 8 | 16 | 20,7 | 16,7 | | 420 | 14 | 46 |
| 10 | 14 | 10,50 | 28 | 43 | 57 | 19,0 | 15,0 | 12,9 | 17 | M 10 | 20 | 28,3 | 23,4 | | 350 | 13 | 76 |
| 12 | 16 | 12,00 | 32 | 50 | 66 | 22,0 | 17,5 | 15,4 | 19 | M 12 | 22 | 34,5 | 32,0 | | 300 | 13 | 115 |
| 14 | 19 | 13,50 | 36 | 57 | 75 | 25,0 | 20,0 | 16,8 | 22 | M 14 | 25 | 39,5 | 42,0 | | 260 | 16 | 170 |
| 16 | 21 | 15,00 | 42 | 64 | 85 | 27,0 | 22,0 | 19,3 | 22 | M 16 | 28 | 60,5 | 52,5 | | 230 | 15 | 230 |
| 18 | 23 | 16,50 | 46 | 71 | 94 | 31,0 | 25,0 | 21,8 | 27 | M 18x1,5 | 32 | 73,0 | 64,0 | | 210 | 15 | 320 |
| 20 | 25 | 18,00 | 50 | 77 | 102 | 34,0 | 27,5 | 24,3 | 32 | M 20x1,5 | 33 | 83,0 | 78,0 | | 190 | 14 | 415 |
| 22 | 28 | 20,00 | 54 | 84 | 111 | 37,0 | 30,0 | 25,8 | 32 | M 22x1,5 | 37 | 100,0 | 97,0 | | 170 | 15 | 540 |
| 25 | 31 | 22,00 | 60 | 94 | 124 | 42,0 | 33,5 | 29,6 | 36 | M 24x2 | 42 | 118,0 | 122,0 | | 150 | 15 | 750 |
| 30 | 37 | 25,00 | 70 | 110 | 145 | 50,0 | 40,0 | 34,8 | 41 | M 30x2 | 51 | 155,0 | 168,0 | | 130 | 17 | 1130 |
| 35 | 43 | 28,00 | 80 | 125 | 165 | 58,0 | 46,0 | 37,7 | 50 | M 36x2 | 56 | 191,0 | 206,0 | | 110 | 19 | 1600 |
| 40 | 49 | 35,00 | 90 | 142 | 187 | 69,0 | 57,0 | 44,2 | 60 | M 42x2 | 60 | 235,0 | 286,0 | | 100 | 16 | 2770 |

Materials:

Housing: Stainless steel to 1.4057, Aisi 431, forged, polished
size 40 turned from stainless steel to 1.4057, Aisi 431

Insert: Stainless steel 1.4571 with PTFE liner bonded to the inner surface

Ball: Stainless steel 1.4404, ground, polished

This series is also available sealed (see page 52) or with threaded bolt (see page 53).

Cetop connections see page 54.

¹⁾ Size 4 on request. Housing turned from stainless steel to 1.4305, Aisi 303

! Please note: The dynamic load "C" of the bearing of some rod ends is in some sizes higher than the static load "C₀" of the rod end.

Rod Ends Series K - Stainless, Maintenance Free

Series

GARSW..RR.316

Rod End with male thread and PTFE liner

For use at high dynamic pressure and tension loads in corrosive environments

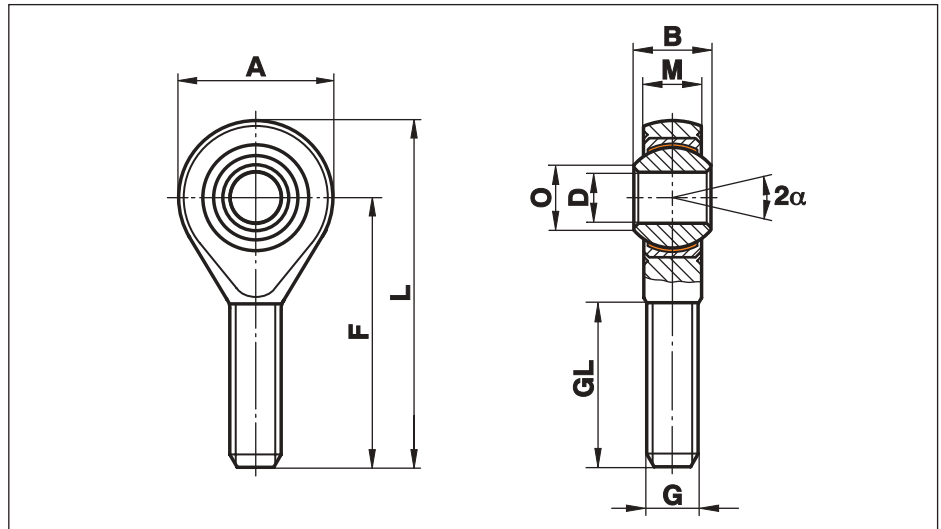

| Size (D H7) | B | M | A | F | L | O | G | GL | Static load C ₀ kN | Dynamic load C kN | Limiting speed rev/min | Maximum Pivoting Angle α (°) | Weight g |
|-----------------|----|-------|----|-----|-----|------|----------|----|-------------------------------|-------------------|------------------------|------------------------------|----------|
| 4 ¹⁾ | 7 | 5,25 | 14 | 30 | 37 | 6,5 | M 4 | 19 | 2,5 | 5,1 | | 14 | 9 |
| 5 | 8 | 6,00 | 18 | 33 | 42 | 7,7 | M 5 | 19 | 6,2 | 7,5 | 600 | 13 | 13 |
| 6 | 9 | 6,75 | 20 | 36 | 46 | 8,9 | M 6 | 21 | 8,8 | 9,3 | 530 | 13 | 20 |
| 8 | 12 | 9,00 | 24 | 42 | 54 | 10,4 | M 8 | 25 | 16,1 | 16,7 | 420 | 14 | 33 |
| 10 | 14 | 10,50 | 28 | 48 | 62 | 12,9 | M 10 | 28 | 25,5 | 23,4 | 350 | 13 | 56 |
| 12 | 16 | 12,00 | 32 | 54 | 70 | 15,4 | M 12 | 32 | 34,5 | 32,0 | 300 | 13 | 87 |
| 14 | 19 | 13,50 | 36 | 60 | 78 | 16,8 | M 14 | 38 | 39,5 | 42,0 | 260 | 16 | 129 |
| 16 | 21 | 15,00 | 42 | 66 | 87 | 19,3 | M 16 | 40 | 60,5 | 52,5 | 230 | 15 | 189 |
| 18 | 23 | 16,50 | 46 | 72 | 95 | 21,8 | M 18x1,5 | 44 | 73,0 | 64,0 | 210 | 15 | 267 |
| 20 | 25 | 18,00 | 50 | 78 | 103 | 24,3 | M 20x1,5 | 47 | 83,0 | 78,0 | 190 | 14 | 348 |
| 22 | 28 | 20,00 | 54 | 84 | 111 | 25,8 | M 22x1,5 | 51 | 100,0 | 97,0 | 170 | 15 | 443 |
| 25 | 31 | 22,00 | 60 | 94 | 124 | 29,6 | M 24x2 | 57 | 118,0 | 122,0 | 150 | 15 | 600 |
| 30 | 37 | 25,00 | 70 | 110 | 145 | 34,8 | M 30x2 | 71 | 155,0 | 168,0 | 130 | 17 | 1030 |
| 35 | 43 | 28,00 | 80 | 125 | 165 | 37,7 | M 36x2 | 73 | 191,0 | 206,0 | 110 | 19 | 1600 |
| 40 | 49 | 35,00 | 90 | 142 | 187 | 44,2 | M 42x2 | 78 | 235,0 | 286,0 | 100 | 16 | 2570 |

only for short-term revolutions recommended

Materials:

Housing: Stainless steel to 1.4057, Aisi 431, forged, polished
size 40 turned from stainless steel to 1.4057, Aisi 431

Insert: Stainless steel 1.4571 with PTFE liner bonded to the inner surface

Ball: Stainless steel 1.4404, ground, polished

This series is also available sealed (see page 52) or with threaded bolt (see page 53).

¹⁾ Size 4 on request. Housing turned from stainless steel to 1.4305, Aisi 303

⚠ Please note: The dynamic load "C" of the bearing of some rod ends is in some sizes higher than the static load "C₀" of the rod end.

Rod Ends Series K - Stainless, Maintenance Free

Series

GIRSW..NIRO

Rod End with female thread and PTFE liner bonded to the inner surface, completely in AISI 316

For use at high dynamic pressure and tension loads in corrosive environments

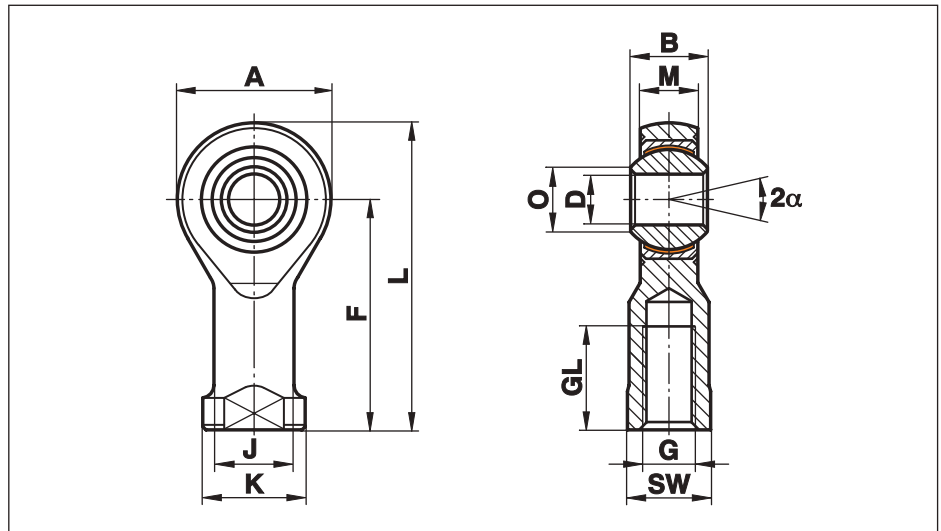

| Size (D H7) | B | M | A | F | L | K | J | O | SW | G | GL | Static load C ₀ kN | Dynamic load C kN | Limiting speed rev/min | Maximum Pivoting Angle α (°) | Weight g | |
|-----------------|----|-------|----|-----|-----|------|------|------|----|----------|----|-------------------------------|-------------------|---|------------------------------|----------|------|
| 4 ¹⁾ | 7 | 5,25 | 14 | 24 | 31 | 9,5 | 7,8 | 6,5 | 8 | M 4 | 12 | 1,7 | 5,1 | only for short-term revolutions recommended | 14 | 11 | |
| 5 | 8 | 6,00 | 18 | 27 | 36 | 11,0 | 9,0 | 7,7 | 9 | M 5 | 10 | 7,0 | 7,5 | | 600 | 13 | 18 |
| 6 | 9 | 6,75 | 20 | 30 | 40 | 13,0 | 10,0 | 8,9 | 11 | M 6 | 12 | 7,5 | 9,3 | | 530 | 13 | 27 |
| 8 | 12 | 9,00 | 24 | 36 | 48 | 16,0 | 12,5 | 10,4 | 13 | M 8 | 16 | 12,5 | 16,7 | | 420 | 14 | 46 |
| 10 | 14 | 10,50 | 28 | 43 | 57 | 19,0 | 15,0 | 12,9 | 17 | M 10 | 20 | 17,5 | 23,4 | | 350 | 13 | 76 |
| 12 | 16 | 12,00 | 32 | 50 | 66 | 22,0 | 17,5 | 15,4 | 19 | M 12 | 22 | 20,5 | 32,0 | | 300 | 13 | 115 |
| 14 | 19 | 13,50 | 36 | 57 | 75 | 25,0 | 20,0 | 16,8 | 22 | M 14 | 25 | 24,0 | 42,0 | | 260 | 16 | 170 |
| 16 | 21 | 15,00 | 42 | 64 | 85 | 27,0 | 22,0 | 19,3 | 22 | M 16 | 28 | 37,0 | 52,5 | | 230 | 15 | 230 |
| 18 | 23 | 16,50 | 46 | 71 | 94 | 31,0 | 25,0 | 21,8 | 27 | M 18x1,5 | 32 | 45,5 | 64,0 | | 210 | 15 | 320 |
| 20 | 25 | 18,00 | 50 | 77 | 102 | 34,0 | 27,5 | 24,3 | 32 | M 20x1,5 | 33 | 51,5 | 78,0 | | 190 | 14 | 415 |
| 22 | 28 | 20,00 | 54 | 84 | 111 | 37,0 | 30,0 | 25,8 | 32 | M 22x1,5 | 37 | 62,0 | 97,0 | | 170 | 15 | 540 |
| 25 | 31 | 22,00 | 60 | 94 | 124 | 42,0 | 33,5 | 29,6 | 36 | M 24x2 | 42 | 73,5 | 122,0 | | 150 | 15 | 750 |
| 30 | 37 | 25,00 | 70 | 110 | 145 | 50,0 | 40,0 | 34,8 | 41 | M 30x2 | 51 | 97,0 | 168,0 | | 130 | 17 | 1130 |
| 35 | 43 | 28,00 | 80 | 125 | 165 | 58,0 | 46,0 | 37,7 | 50 | M 36x2 | 56 | 121,0 | 206,0 | | 110 | 19 | 1600 |
| 40 | 49 | 35,00 | 90 | 142 | 187 | 69,0 | 57,0 | 44,2 | 60 | M 42x2 | 60 | 145,0 | 286,0 | | 100 | 16 | 2770 |

Materials:

Housing: Stainless steel to 1.4404, Aisi 316

Insert: Stainless steel 1.4571 with PTFE liner bonded to the inner surface

Ball: Stainless steel 1.4404, Aisi316, ground, polished

This series is also available sealed (see page 52) or with threaded bolt (see page 53).

Cetop connections see page 54.

¹⁾ on request

! Please note: The dynamic load "C" of the bearing of some rod ends is in some sizes higher than the static load "C₀" of the rod end.

Rod Ends Series K - Stainless, Maintenance Free

Series GARSW..NIRO

Rod End with male thread and PTFE liner bonded to the inner surface, completely in AISI 316

For use at high dynamic pressure and tension loads in corrosive environments

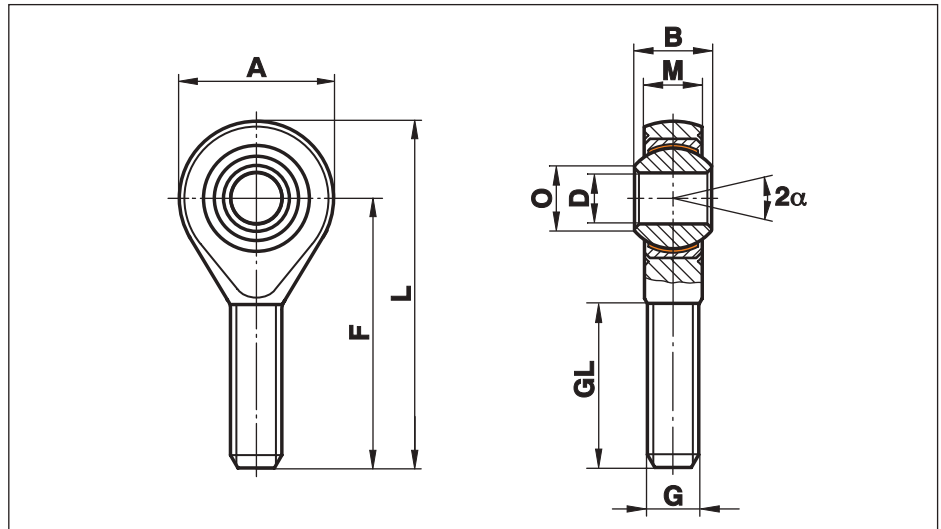

| Size (D H7) | B | M | A | F | L | O | G | GL | Static load C ₀ kN | Dynamic load C kN | Limiting speed rev/min | Maximum Pivoting Angle α (°) | Weight g |
|-----------------|----|-------|----|-----|-----|------|----------|----|-------------------------------|-------------------|------------------------|------------------------------|----------|
| 4 ¹⁾ | 7 | 5,25 | 14 | 30 | 37 | 6,5 | M 4 | 19 | 1,7 | 5,1 | | 14 | 9 |
| 5 | 8 | 6,00 | 18 | 33 | 42 | 7,7 | M 5 | 19 | 3,5 | 7,5 | 600 | 13 | 13 |
| 6 | 9 | 6,75 | 20 | 36 | 46 | 8,9 | M 6 | 21 | 5,5 | 9,3 | 530 | 13 | 20 |
| 8 | 12 | 9,00 | 24 | 42 | 54 | 10,4 | M 8 | 25 | 10,0 | 16,7 | 420 | 14 | 33 |
| 10 | 14 | 10,50 | 28 | 48 | 62 | 12,9 | M 10 | 28 | 16,0 | 23,4 | 350 | 13 | 56 |
| 12 | 16 | 12,00 | 32 | 54 | 70 | 15,4 | M 12 | 32 | 20,0 | 32,0 | 300 | 13 | 87 |
| 14 | 19 | 13,50 | 36 | 60 | 78 | 16,8 | M 14 | 38 | 24,0 | 42,0 | 260 | 16 | 129 |
| 16 | 21 | 15,00 | 42 | 66 | 87 | 19,3 | M 16 | 40 | 37,0 | 52,5 | 230 | 15 | 189 |
| 18 | 23 | 16,50 | 46 | 72 | 95 | 21,8 | M 18x1,5 | 44 | 45,5 | 64,0 | 210 | 15 | 267 |
| 20 | 25 | 18,00 | 50 | 78 | 103 | 24,3 | M 20x1,5 | 47 | 51,5 | 78,0 | 190 | 14 | 348 |
| 22 | 28 | 20,00 | 54 | 84 | 111 | 25,8 | M 22x1,5 | 51 | 62,0 | 97,0 | 170 | 15 | 443 |
| 25 | 31 | 22,00 | 60 | 94 | 124 | 29,6 | M 24x2 | 57 | 73,5 | 122,0 | 150 | 15 | 600 |
| 30 | 37 | 25,00 | 70 | 110 | 145 | 34,8 | M 30x2 | 71 | 97,0 | 168,0 | 130 | 17 | 1030 |
| 35 | 43 | 28,00 | 80 | 125 | 165 | 37,7 | M 36x2 | 73 | 121,5 | 206,0 | 110 | 19 | 1600 |
| 40 | 49 | 35,00 | 90 | 142 | 187 | 44,2 | M 42x2 | 78 | 145,0 | 286,0 | 100 | 16 | 2570 |

only for short-term revolutions recommended

Materials:

Housing: Stainless steel to 1.4404, Aisi 316

Insert: Stainless steel 1.4571 with PTFE liner bonded to the inner surface

Ball: Stainless steel 1.4404, Aisi316, ground, polished

This series is also available sealed (see page 52) or with threaded bolt (see page 53).

Cetop connections see page 54.

¹⁾ on request

⚠ Please note: The dynamic load "C" of the bearing of some rod ends is in some sizes higher than the static load "C₀" of the rod end.

Rod Ends Series K - Steel on Steel

Series GIO

Rod End with female thread, without the insert

High axial load in one direction only. To be used only with limited oscillating movements

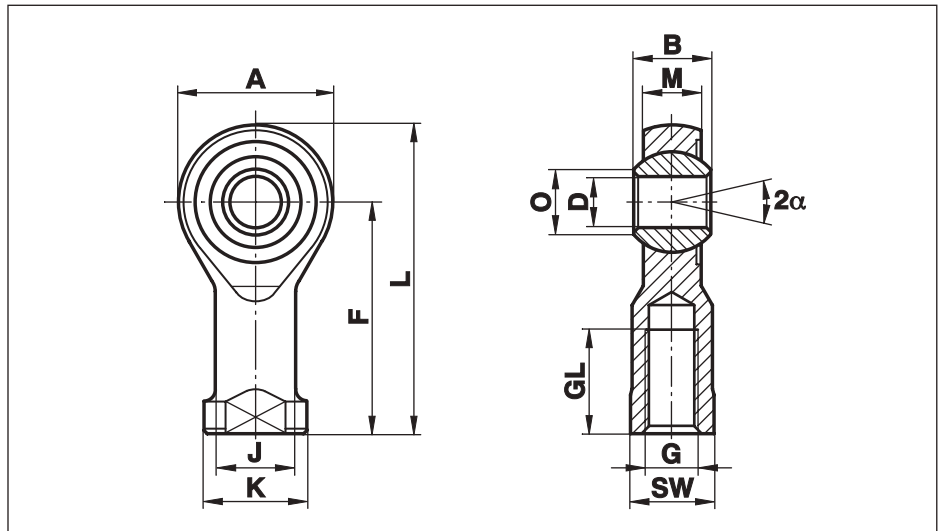

| Size (D H7) | B | M | A | F | L | K | J | O | SW | G | GL | Static load C ₀ kN | Dynamic load C kN | Limiting speed rev/min | Maximum Pivoting Angle α (°) | Weight g |
|-------------|----|-------|----|----|-----|----|------|------|----|----------|----|-------------------------------|-------------------|---|------------------------------|----------|
| 5 | 8 | 6,00 | 18 | 27 | 36 | 11 | 9,0 | 7,7 | 9 | M 5 | 10 | 12,0 | 2,2 | not to be used for complete revolutions | 13 | 18 |
| 6 | 9 | 6,75 | 20 | 30 | 40 | 13 | 10,0 | 8,9 | 11 | M 6 | 12 | 14,3 | 2,8 | | 13 | 27 |
| 8 | 12 | 9,00 | 24 | 36 | 48 | 16 | 12,5 | 10,4 | 13 | M 8 | 16 | 21,7 | 4,6 | | 14 | 46 |
| 10 | 14 | 10,50 | 28 | 43 | 57 | 19 | 15,0 | 12,9 | 17 | M 10 | 20 | 27,8 | 6,5 | | 13 | 76 |
| 12 | 16 | 12,00 | 32 | 50 | 66 | 22 | 17,5 | 15,4 | 19 | M 12 | 22 | 35,0 | 8,5 | | 13 | 115 |
| 14 | 19 | 13,50 | 36 | 57 | 75 | 25 | 20,0 | 16,8 | 22 | M 14 | 25 | 32,5 | 11,0 | | 16 | 170 |
| 16 | 21 | 15,00 | 42 | 64 | 85 | 27 | 22,0 | 19,3 | 22 | M 16 | 28 | 46,0 | 14,0 | | 15 | 230 |
| 20 | 25 | 18,00 | 50 | 77 | 102 | 34 | 27,5 | 24,3 | 32 | M 20x1,5 | 33 | 63,0 | 20,0 | | 14 | 415 |

Materials:

Housing: up to size 12 turned, from free-cutting steel to 9SMnPb28K, 12L13, galvanised from size 14 forged, from heat-treated galvanised steel to C22, M1023

Ball: Bearing steel to 100Cr6, Aisi 52100, hardened, ground, polished

Cetop connections see page 54.

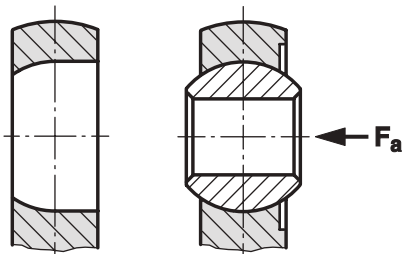

The base in the steel housing is cylindrically turned from one side and, starting from the centre line, it runs to suit the ball's contour (see drawing). Hence a high axial load towards the turned radius is possible.

⚠ This series is not regreasable through grease nipple

Rod Ends Series K - Steel on Steel

Series GAO

Rod End with male thread, without the insert

High axial load in one direction only. To be used only with limited oscillating movements

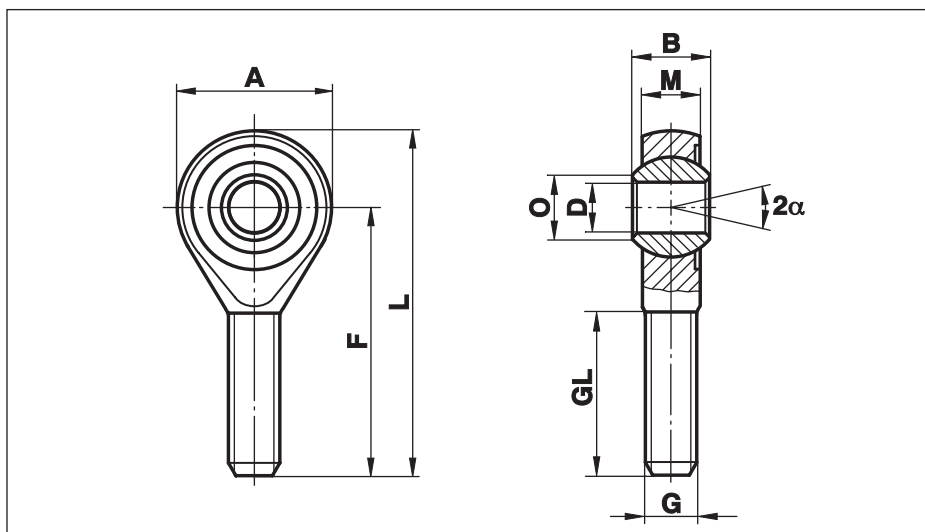

| Size (D H7) | B | M | A | F | L | O | G | GL | Static load C ₀ kN | Dynamic load C kN | Limiting speed rev/min | Maximum Pivoting Angle α (°) | Weight g |
|-------------|----|-------|----|----|-----|------|----------|----|-------------------------------|-------------------|---|------------------------------|----------|
| 5 | 8 | 6,00 | 18 | 33 | 42 | 7,7 | M 5 | 19 | 4,3 | 2,2 | not to be used for complete revolutions | 13 | 13 |
| 6 | 9 | 6,75 | 20 | 36 | 46 | 8,9 | M 6 | 21 | 6,0 | 2,8 | | 13 | 20 |
| 8 | 12 | 9,00 | 24 | 42 | 54 | 10,4 | M 8 | 25 | 11,0 | 4,6 | | 14 | 33 |
| 10 | 14 | 10,50 | 28 | 48 | 62 | 12,9 | M 10 | 28 | 17,4 | 6,5 | | 13 | 56 |
| 12 | 16 | 12,00 | 32 | 54 | 70 | 15,4 | M 12 | 32 | 25,5 | 8,5 | | 13 | 87 |
| 14 | 19 | 13,50 | 36 | 60 | 78 | 16,8 | M 14 | 38 | 26,5 | 11,0 | | 16 | 129 |
| 16 | 21 | 15,00 | 42 | 66 | 87 | 19,3 | M 16 | 40 | 36,5 | 14,0 | | 15 | 189 |
| 20 | 25 | 18,00 | 50 | 78 | 103 | 24,3 | M 20x1,5 | 47 | 63,0 | 20,5 | | 14 | 348 |

Materials:

Housing: up to size 12 turned, from free-cutting steel to 9SMnPb28K, 12L13, galvanised from size 14 forged, from heat-treated galvanised steel to C22, M1023

Ball: Bearing steel to 100Cr6, Aisi 52100, hardened, ground, polished

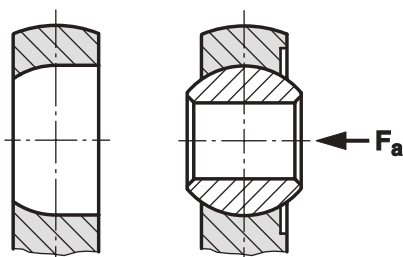

The base in the steel housing is cylindrically turned from one side and, starting from the centre line, it runs to suit the ball's contour (see drawing). Hence a high axial load towards the turned radius is possible.

⚠ This series is not regreasable through grease nipple

Rod Ends Series K - Maintenance Free

Series GIOW

Rod End with female thread, without the insert

For use in applications involving minimum axial loads and limited oscillating movements

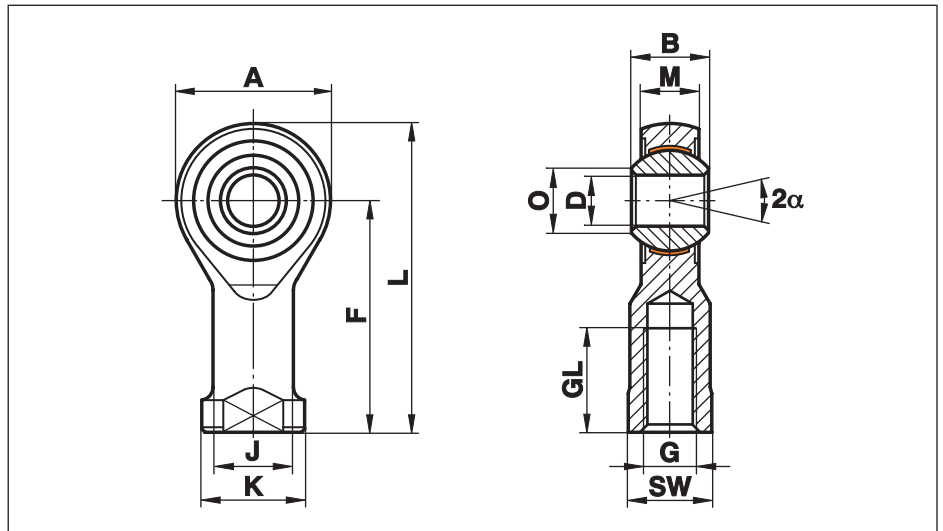

| Size (D H7) | B | M | A | F | L | K | J | O | SW | G | GL | Static load C ₀ kN | Dynamic load C kN | Limiting speed rev/min | Maximum Pivoting Angle α (°) | Weight g |
|-------------|----|-------|----|----|-----|------|------|------|----|----------|----|-------------------------------|-------------------|---|------------------------------|----------|
| 4 | 7 | 5,25 | 14 | 24 | 31 | 9,5 | 7,8 | 6,5 | 8 | M 4 | 12 | 5,2 | 0,8 | not to be used for complete revolutions | 14 | 11 |
| 5 | 8 | 6,00 | 18 | 27 | 36 | 11,0 | 9,0 | 7,7 | 9 | M 5 | 10 | 9,8 | 1,1 | | 13 | 18 |
| 6 | 9 | 6,75 | 20 | 30 | 40 | 13,0 | 10,0 | 8,9 | 11 | M 6 | 12 | 11,8 | 1,4 | | 13 | 27 |
| 8 | 12 | 9,00 | 24 | 36 | 48 | 16,0 | 12,5 | 10,4 | 13 | M 8 | 16 | 17,3 | 2,2 | | 14 | 46 |
| 10 | 14 | 10,50 | 28 | 43 | 57 | 19,0 | 15,0 | 12,9 | 17 | M 10 | 20 | 22,3 | 3,1 | | 13 | 76 |
| 12 | 16 | 12,00 | 32 | 50 | 66 | 22,0 | 17,5 | 15,4 | 19 | M 12 | 22 | 28,5 | 4,0 | | 13 | 115 |
| 14 | 19 | 13,50 | 36 | 57 | 75 | 25,0 | 20,0 | 16,8 | 22 | M 14 | 25 | 26,0 | 5,0 | | 16 | 170 |
| 16 | 21 | 15,00 | 42 | 64 | 85 | 27,0 | 22,0 | 19,3 | 22 | M 16 | 28 | 39,0 | 7,0 | | 15 | 230 |
| 20 | 25 | 18,00 | 50 | 77 | 102 | 34,0 | 27,5 | 24,3 | 32 | M 20x1,5 | 33 | 53,0 | 9,5 | 14 | 415 | |

Materials:

Housing: up to size 12 turned, from free-cutting steel to 9SMnPb28K, 12L13, galvanised from size 14 forged, from heat-treated galvanised steel to C22, M1023 with PTFE liner bonded to the inner surface

Ball: Bearing steel to 100Cr6, Aisi 52100, hardened, ground, polished

Cetop connections see page 54.

Rod Ends Series K - Maintenance Free

Series GAOW

Rod End with male thread, without the insert

For use in applications involving minimum axial loads and limited oscillating movements

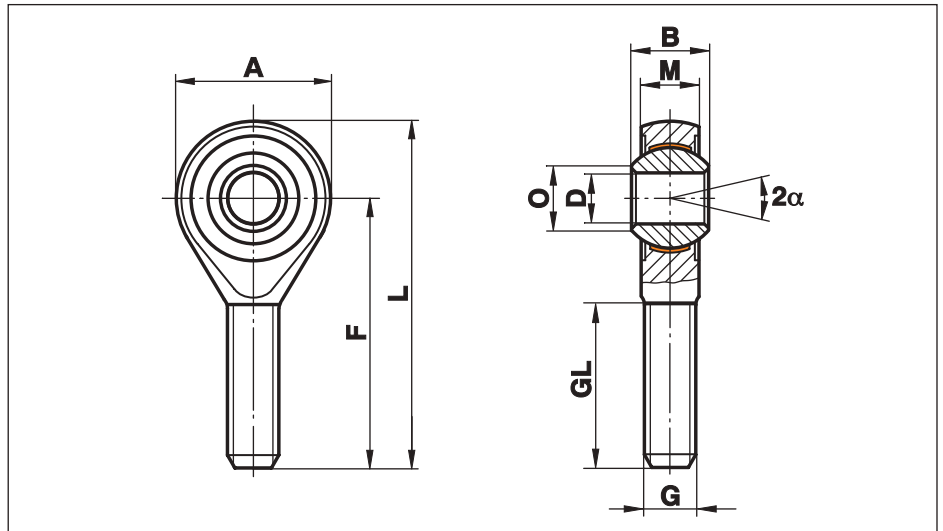

| Size (D H7) | B | M | A | F | L | O | G | GL | Static load C ₀ kN | Dynamic load C kN | Limiting speed rev/min | Maximum Pivoting Angle α (°) | Weight g |
|-------------|----|-------|----|----|-----|------|----------|----|-------------------------------|-------------------|---|------------------------------|----------|
| 4 | 7 | 5,25 | 14 | 30 | 37 | 6,5 | M 4 | 19 | 2,6 | 0,8 | not to be used for complete revolutions | 14 | 9 |
| 5 | 8 | 6,00 | 18 | 33 | 42 | 7,7 | M 5 | 19 | 4,3 | 1,1 | | 13 | 13 |
| 6 | 9 | 6,75 | 20 | 36 | 46 | 8,9 | M 6 | 21 | 6,0 | 1,4 | | 13 | 20 |
| 8 | 12 | 9,00 | 24 | 42 | 54 | 10,4 | M 8 | 25 | 11,0 | 2,2 | | 14 | 33 |
| 10 | 14 | 10,50 | 28 | 48 | 62 | 12,9 | M 10 | 28 | 17,4 | 3,1 | | 13 | 56 |
| 12 | 16 | 12,00 | 32 | 54 | 70 | 15,4 | M 12 | 32 | 25,5 | 4,0 | | 13 | 87 |
| 14 | 19 | 13,50 | 36 | 60 | 78 | 16,8 | M 14 | 38 | 26,0 | 5,0 | | 16 | 129 |
| 16 | 21 | 15,00 | 42 | 66 | 87 | 19,3 | M 16 | 40 | 36,5 | 7,0 | | 15 | 189 |
| 20 | 25 | 18,00 | 50 | 78 | 103 | 24,3 | M 20x1,5 | 47 | 53,0 | 9,5 | 14 | 348 | |

Materials:

Housing: up to size 12 turned, from free-cutting steel to 9SMnPb28K, 12L13, galvanised from size 14 forged, from heat-treated galvanised steel to C22, M1023 with PTFE liner bonded to the inner surface

Ball: Bearing steel to 100Cr6, Aisi 52100, hardened, ground, polished

Rod Ends Series K - Sealed Version

Series G...-2RS

Sealed Rod Ends
Series K in the following
versions:

- G.S
- G.XS
- G.RS (..R)
- G.SW
- G.XSW
- G.RSW (..R, ..RR, ..RR.316)

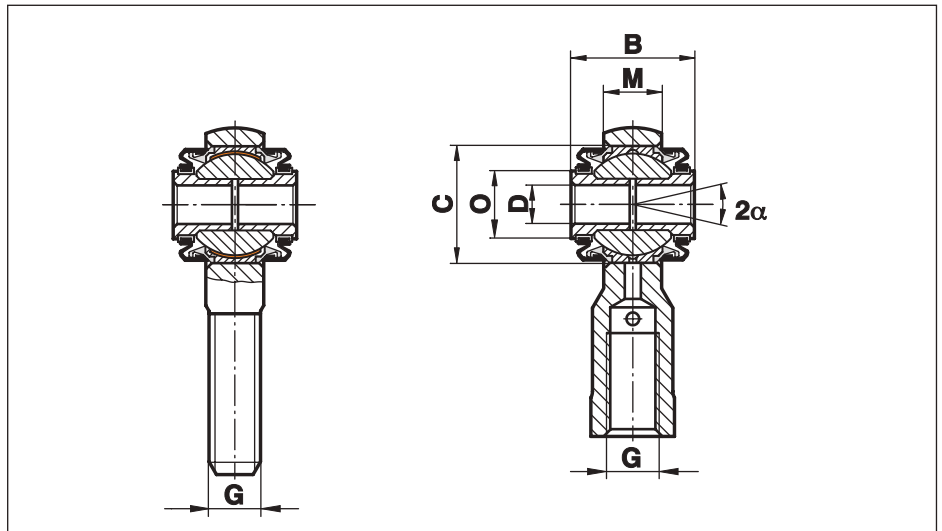

| Size | D | B | M | C | O | G | Pivoting Angle α (°) |
|------|----|----|------|------|------|----------|-----------------------------|
| 8 | 6 | 19 | 9,0 | 18,0 | 10,5 | M 8 | 10 |
| 10 | 8 | 21 | 10,5 | 21,0 | 12,5 | M 10 | 10 |
| 12 | 10 | 23 | 12,0 | 25,5 | 15,5 | M 12 | 10 |
| 14 | 12 | 26 | 13,5 | 29,0 | 17,0 | M 14 | 12 |
| 16 | 14 | 28 | 15,0 | 32,0 | 18,5 | M 16 | 12 |
| 20 | 18 | 32 | 18,0 | 38,0 | 22,0 | M 20x1,5 | 12 |

Materials:

Rod Ends: See description of respective version

2RS seals: NBR-Elastomer, temperature resistance -30° to $+120^{\circ}$ Celsius, resistant to mineral oils, grease and petrol

Retainers: Brass

Spacers: Stainless steel to 1.4305, Aisi 303

Rod Ends Series K - With Threaded Bolt

Series G.....-BO

Rod Ends and Spherical Plain Bearings with threaded bolt.
For use as a right angle connector:

- G.S
- G.XS
- G.RS (..R)
- G.SW
- G.XSW
- G.RSW (..R, ..RR, ..RR.316)

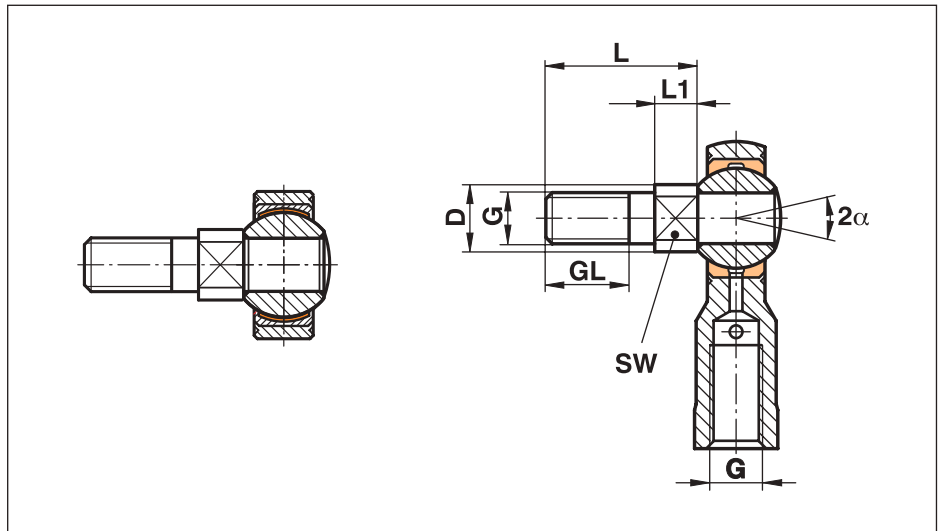

| Size | L | L1 | GL | G | D | SW | Weight of bolt g |
|------|------|------|----|------|------|----|------------------|
| 5 | 16,0 | 5,0 | 9 | M 5 | 7,8 | 7 | 5 |
| 6 | 18,5 | 5,5 | 10 | M 6 | 9,0 | 8 | 10 |
| 8 | 23,5 | 6,5 | 13 | M 8 | 10,5 | 8 | 12 |
| 10 | 28,0 | 7,0 | 17 | M 10 | 13,0 | 12 | 25 |
| 12 | 32,5 | 7,5 | 20 | M 12 | 15,0 | 14 | 40 |
| 14 | 37,5 | 8,5 | 22 | M 14 | 17,0 | 14 | 65 |
| 16 | 42,5 | 9,5 | 24 | M 16 | 19,0 | 17 | 90 |
| 20 | 57,0 | 12,0 | 35 | M 20 | 24,0 | 22 | 200 |

Materials:

Rod Ends and Sphericals: See description of respective version

Threaded bolt: Free-cutting steel to 9SMnPb28K, 12L13, zinc plated or stainless steel to 1.4305, Aisi 303

Rod Ends Series K - CETOP

Rod Ends for pneumatic cylinders to CETOP RP 103 P

All female Rod Ends series are available with CETOP dimensions for pneumatic cylinders

Connections to
ISO 8139

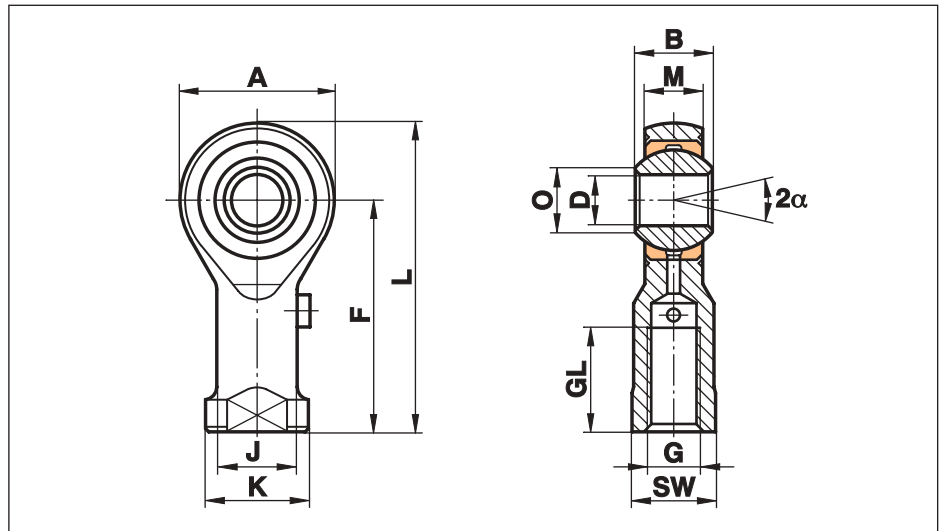

| Size (D) | B | M | A | F | L | K | J | O | SW | G | GL | Static load C ₀ kN | Dynamic load C kN | Limiting speed rev/min | for cylinder-Ø |
|----------|----|-------|-----|-----|-----|----|------|------|----|-----------|----|-------------------------------|-------------------|------------------------|----------------|
| 5 | 8 | 6,00 | 18 | 27 | 36 | 11 | 9,0 | 7,7 | 9 | M 4 | 10 | | | | 8 + 10 |
| 6 | 9 | 6,75 | 20 | 30 | 40 | 13 | 10,0 | 8,9 | 11 | M 6 | 12 | | | | 12 + 16 |
| 8 | 12 | 9,00 | 24 | 36 | 48 | 16 | 12,5 | 10,4 | 13 | M 8 | 16 | | | | 20 |
| 10 | 14 | 10,50 | 28 | 43 | 57 | 19 | 15,0 | 12,9 | 17 | M 10x1,25 | 20 | | | | 25 + 32 |
| 12 | 16 | 12,00 | 32 | 50 | 66 | 22 | 17,5 | 15,4 | 19 | M 12x1,25 | 22 | | | | 40 + 50 |
| 16 | 21 | 15,00 | 42 | 64 | 85 | 27 | 22,0 | 19,3 | 22 | M 16x1,5 | 28 | | | | 50 + 63 |
| 20 | 25 | 18,00 | 50 | 77 | 102 | 34 | 27,5 | 24,3 | 32 | M 20x1,5 | 33 | | | | 80 + 100 |
| 25 | 31 | 22,00 | 60 | 94 | 124 | 42 | 33,5 | 29,6 | 36 | M 24x2 | 42 | | | | 125 |
| 30 | 37 | 25,00 | 70 | 110 | 145 | 51 | 40,0 | 34,8 | 41 | M 27x2 | 51 | | | | 125 |
| 35 | 43 | 28,00 | 80 | 125 | 165 | 56 | 46,0 | 37,7 | 50 | M 36x2 | 56 | | | | 160 + 200 |
| 40 | 49 | 35,00 | 90 | 142 | 187 | 69 | 57,0 | 44,2 | 60 | M 42x2 | 60 | | | | 250 |
| 50 | 60 | 45,00 | 116 | 160 | 218 | 78 | 65,0 | 55,9 | 65 | M 48x2 | 65 | | | | 320 |

Materials:

See previous pages

Ordering Details:

When ordering please specify Rod Ends series and thread, for example:

GI 10x1,25

GISW 16x1,5

GIRSW 30 M27x2

Spherical Plain Bearings Series K - Standard

Series GL

Spherical Plain Bearings with outer ring, from free-cutting steel, zinc plated and regreasable

Especially suited for axial loads

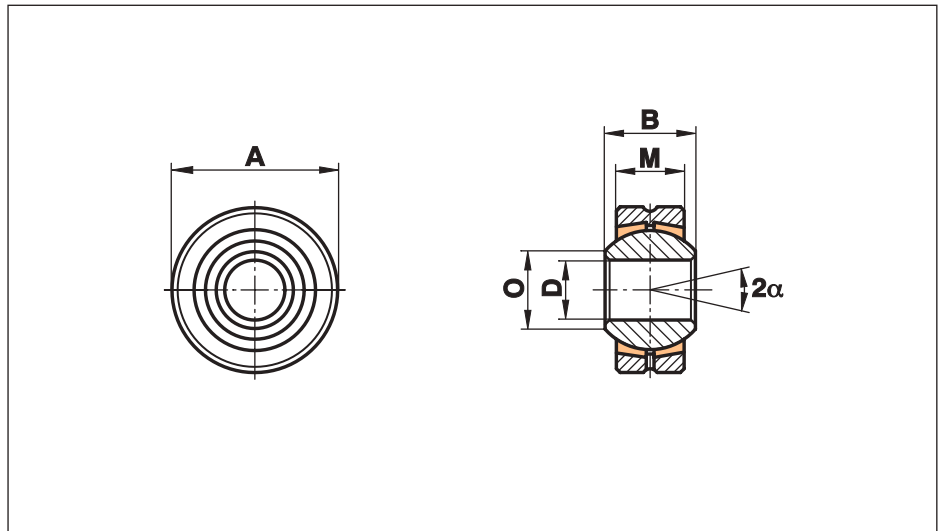

| Size (D H7) | B | M | A (h6) | O | dK | Static load C ₀ kN | Dynamic load C kN | Limiting speed rev/min | Maximum Pivoting Angle α (°) | Weight g | |
|-------------|----|-------|--------|------|-------|-------------------------------|-------------------|------------------------|---|----------|-----|
| 5 | 8 | 6,00 | 16 | 7,7 | 11,11 | 10,0 | 2,5 | 900 | only for short-term revolutions recommended | 13 | 8 |
| 6 | 9 | 6,75 | 18 | 8,9 | 12,70 | 12,8 | 3,2 | 760 | | 13 | 12 |
| 8 | 12 | 9,00 | 22 | 10,4 | 15,87 | 21,6 | 5,4 | 620 | | 14 | 23 |
| 10 | 14 | 10,50 | 26 | 12,9 | 19,05 | 30,0 | 7,5 | 500 | | 13 | 38 |
| 12 | 16 | 12,00 | 30 | 15,4 | 22,22 | 40,0 | 10,0 | 450 | | 13 | 58 |
| 14 | 19 | 13,50 | 34 | 16,8 | 25,40 | 51,5 | 13,0 | 360 | | 16 | 83 |
| 16 | 21 | 15,00 | 38 | 19,3 | 28,57 | 64,5 | 16,0 | 350 | | 15 | 115 |
| 18 | 23 | 16,50 | 42 | 21,8 | 31,75 | 78,5 | 19,5 | 320 | | 15 | 150 |
| 20 | 25 | 18,00 | 46 | 24,3 | 34,92 | 94,5 | 23,5 | 280 | | 14 | 200 |
| 22 | 28 | 20,00 | 50 | 25,8 | 38,10 | 114,0 | 29,0 | 250 | | 15 | 270 |
| 25 | 31 | 22,00 | 56 | 29,6 | 42,86 | 142,0 | 35,0 | 230 | | 15 | 375 |

Materials:

Outer ring: Free-cutting steel to 9SMnPb28K, 12L13, turned, galvanised

Insert: Special brass to CuZn40Al1

Ball: Bearing steel to 100Cr6, Aisi 52100, hardened, ground, polished

Spherical Plain Bearings Series K - Heavy Duty

Series GLXS

Spherical Plain Bearing,
regreasable

For use at high revs

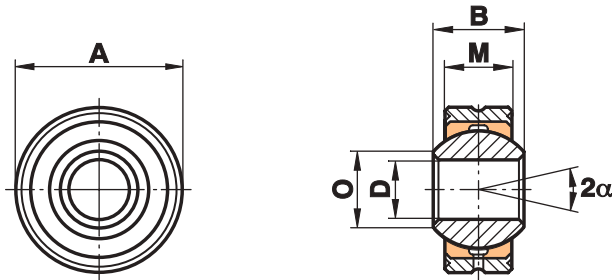

| Size (D H7) | B | M | A (h6) | O | dK | Static load C ₀ kN | Dynamic load C kN | Limiting speed rev/min | Maximum Pivoting Angle α (°) | Weight g | |
|--------------------|----|-------|--------|------|-------|-------------------------------------|-------------------------|------------------------------|---|-------------|-----|
| 3 ^{1) 2)} | 6 | 4,50 | 12 | 5,1 | 7,94 | 10,8 | 1,8 | | only for short-term revolutions recommended | 14 | 4 |
| 4 ^{1) 2)} | 7 | 5,25 | 14 | 6,5 | 9,52 | 14,5 | 2,5 | | | 14 | 6 |
| 5 | 8 | 6,00 | 16 | 7,7 | 11,11 | 19,8 | 3,3 | 1200 | | 13 | 8 |
| 6 | 9 | 6,75 | 18 | 8,9 | 12,70 | 25,8 | 4,3 | 1500 | | 13 | 12 |
| 8 | 12 | 9,00 | 22 | 10,4 | 15,87 | 42,6 | 7,1 | 1200 | | 14 | 23 |
| 10 | 14 | 10,50 | 26 | 12,9 | 19,05 | 60,0 | 10,0 | 1000 | | 13 | 38 |
| 12 | 16 | 12,00 | 30 | 15,4 | 22,22 | 80,0 | 13,5 | 860 | | 13 | 58 |
| 14 | 19 | 13,50 | 34 | 16,8 | 25,40 | 102,5 | 17,0 | 750 | | 16 | 83 |
| 16 | 21 | 15,00 | 38 | 19,3 | 28,57 | 128,5 | 21,5 | 660 | | 15 | 115 |
| 18 | 23 | 16,50 | 42 | 21,8 | 31,75 | 157,0 | 26,0 | 600 | | 15 | 150 |
| 20 | 25 | 18,00 | 46 | 24,3 | 34,92 | 188,5 | 31,5 | 540 | | 14 | 200 |
| 22 | 28 | 20,00 | 50 | 25,8 | 38,10 | 229,0 | 38,0 | 500 | | 15 | 270 |
| 25 | 31 | 22,00 | 56 | 29,6 | 42,86 | 293,0 | 47,0 | 440 | 15 | 375 | |
| 30 | 37 | 25,00 | 66 | 34,8 | 50,80 | 381,0 | 64,0 | 370 | 17 | 540 | |
| 35 | 43 | 28,00 | 78 | 37,7 | 57,15 | 480,0 | 80,0 | 330 | 19 | 850 | |
| 40 | 49 | 35,00 | 87 | 44,2 | 65,96 | 693,0 | 116,0 | 290 | 16 | 1400 | |

Materials:

Outer ring: Free-cutting steel to 9SMnPb28K, 12L13, turned, galvanised

Insert: Special high strength bronze to CuSn8

Ball: Bearing steel to 100Cr6, Aisi 52100, hardened, ground, polished

This series is also available with threaded bolt (see page 53).

¹⁾ without lubrication hole

²⁾ Outer Ring as one piece to CuSn8

Spherical Plain Bearings - corrosion protection class III, requiring maintenance

Series GLRS

Spherical Plain Bearing,
regreasable

For use at high revs in
corrosive environments

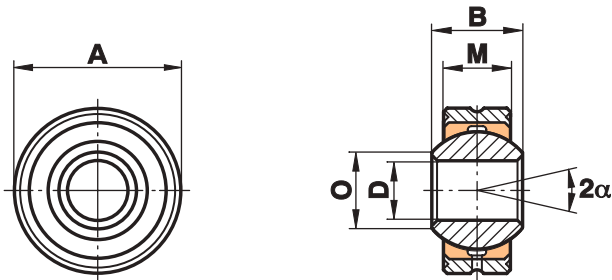

| Size (D H7) | B | M | A (h6) | O | dK | Static load C ₀ kN | Dynamic load C kN | Limiting speed rev/min | Maximum Pivoting Angle α (°) | Weight g | |
|--------------------|----|-------|--------|------|-------|-------------------------------------|-------------------------|------------------------------|---|-------------|-----|
| 3 ^{1) 2)} | 6 | 4,50 | 12 | 5,1 | 7,94 | 10,8 | 1,8 | | only for short-term revolutions recommended | 14 | 5 |
| 5 | 8 | 6,00 | 16 | 7,7 | 11,11 | 19,8 | 3,3 | 1200 | | 13 | 8 |
| 6 | 9 | 6,75 | 18 | 8,9 | 12,70 | 25,8 | 4,3 | 1500 | | 13 | 12 |
| 8 | 12 | 9,00 | 22 | 10,4 | 15,87 | 42,6 | 7,1 | 1200 | | 14 | 23 |
| 10 | 14 | 10,50 | 26 | 12,9 | 19,05 | 60,0 | 10,0 | 1000 | | 13 | 38 |
| 12 | 16 | 12,00 | 30 | 15,4 | 22,22 | 80,0 | 13,5 | 860 | | 13 | 58 |
| 14 | 19 | 13,50 | 34 | 16,8 | 25,40 | 102,5 | 17,0 | 750 | | 16 | 83 |
| 16 | 21 | 15,00 | 38 | 19,3 | 28,57 | 128,5 | 21,5 | 660 | | 15 | 115 |
| 18 | 23 | 16,50 | 42 | 21,8 | 31,75 | 157,0 | 26,0 | 600 | | 15 | 150 |
| 20 | 25 | 18,00 | 46 | 24,3 | 34,92 | 188,5 | 31,5 | 540 | | 14 | 200 |
| 22 | 28 | 20,00 | 50 | 25,8 | 38,10 | 229,0 | 38,0 | 500 | | 15 | 270 |
| 25 | 31 | 22,00 | 56 | 29,6 | 42,86 | 293,0 | 47,0 | 440 | | 15 | 375 |
| 30 | 37 | 25,00 | 66 | 34,8 | 50,80 | 381,0 | 64,0 | 370 | 17 | 540 | |
| 35 | 43 | 28,00 | 78 | 37,7 | 57,15 | 480,0 | 80,0 | 330 | 19 | 850 | |
| 40 | 49 | 35,00 | 87 | 44,2 | 45,96 | 693,0 | 116,0 | 290 | 16 | 1400 | |

Materials:

Outer ring: Stainless steel to 1.4305, Aisi 303, turned

Insert: Special high strength bronze to CuSn8

Ball: Bearing steel to 100Cr6, Aisi 52100, hardened, ground, polished, hard chrome plated on the running surface

This series is also available with threaded bolt (see page 53).

¹⁾ without lubrication hole

²⁾ Outer Ring as one piece to CuSn8

Spherical Plain Bearings series K - stainless, requiring maintenance

Series GLRS..R

Spherical Plain Bearing,
regreasable

For use at high revs in
corrosive environments

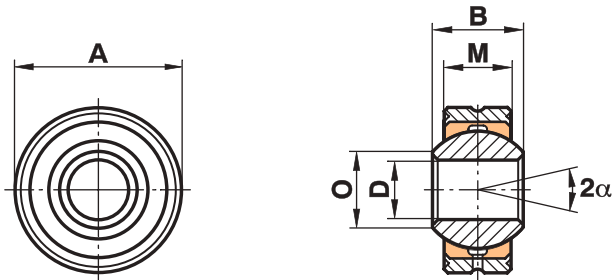

| Size (D H7) | B | M | A (h6) | O | dK | Static load C ₀ kN | Dynamic load C kN | Limiting speed rev/min | Maximum Pivoting Angle α (°) | Weight g | |
|--------------------|----|-------|--------|------|-------|-------------------------------------|-------------------------|------------------------------|--|-------------|-----|
| 3 ^{1) 2)} | 6 | 4,50 | 12 | 5,1 | 7,94 | 10,8 | 1,8 | | only for short-term revolutions recommended | 14 | 5 |
| 5 | 8 | 6,00 | 16 | 7,7 | 11,11 | 19,8 | 3,3 | 1200 | | 13 | 8 |
| 6 | 9 | 6,75 | 18 | 8,9 | 12,70 | 25,8 | 4,3 | 1500 | | 13 | 12 |
| 8 | 12 | 9,00 | 22 | 10,4 | 15,87 | 42,6 | 7,1 | 1200 | | 14 | 23 |
| 10 | 14 | 10,50 | 26 | 12,9 | 19,05 | 60,0 | 10,0 | 1000 | | 13 | 38 |
| 12 | 16 | 12,00 | 30 | 15,4 | 22,22 | 80,0 | 13,5 | 860 | | 13 | 58 |
| 14 | 19 | 13,50 | 34 | 16,8 | 25,40 | 102,5 | 17,0 | 750 | | 16 | 83 |
| 16 | 21 | 15,00 | 38 | 19,3 | 28,57 | 128,5 | 21,5 | 660 | | 15 | 115 |
| 18 | 23 | 16,50 | 42 | 21,8 | 31,75 | 157,0 | 26,0 | 600 | | 15 | 150 |
| 20 | 25 | 18,00 | 46 | 24,3 | 34,92 | 188,5 | 31,5 | 540 | | 14 | 200 |
| 22 | 28 | 20,00 | 50 | 25,8 | 38,10 | 229,0 | 38,0 | 500 | | 15 | 270 |
| 25 | 31 | 22,00 | 56 | 29,6 | 42,86 | 293,0 | 47,0 | 440 | | 15 | 375 |
| 30 | 37 | 25,00 | 66 | 34,8 | 50,80 | 381,0 | 64,0 | 370 | 17 | 540 | |
| 35 | 43 | 28,00 | 78 | 37,7 | 57,15 | 480,0 | 80,0 | 330 | 19 | 850 | |
| 40 | 49 | 35,00 | 87 | 44,2 | 45,96 | 693,0 | 116,0 | 290 | 16 | 1400 | |

Materials:

Outer ring: Stainless steel to 1.4305, Aisi 303, turned

Insert: Special high strength bronze to CuSn8

Ball: Stainless steel 1.4034 Aisi420C, hardened, ground, polished

This series is also available with threaded bolt (see page 53).

1) not regreasable through lubrication groove

2) Outer Ring as one piece to CuSn8

Spherical Plain Bearings Series K - Maintenance Free

Series GLXSW

Spherical Plain Bearing,
maintenance free

For use at higher
dynamic pressure and
tension loads

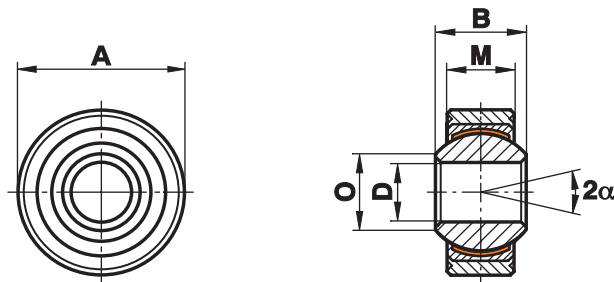

| Size (D H7) | B | M | A (h6) | O | dK | Static load C ₀ kN | Dynamic load C kN | Limiting speed rev/min | Maximum Pivoting Angle α (°) | Weight g | |
|-----------------|----|-------|--------|------|-------|-------------------------------------|-------------------------|------------------------------|---|-------------|-----|
| 4 ¹⁾ | 7 | 5,25 | 14 | 6,5 | 9,52 | 9,5 | 5,7 | 700 | only for short-term revolutions recommended | 14 | 5 |
| 5 | 8 | 6,00 | 16 | 7,7 | 11,11 | 12,5 | 7,5 | 600 | | 13 | 8 |
| 6 | 9 | 6,75 | 18 | 8,9 | 12,70 | 15,5 | 9,3 | 530 | | 13 | 12 |
| 8 | 12 | 9,00 | 22 | 10,4 | 15,87 | 27,8 | 16,7 | 420 | | 14 | 23 |
| 10 | 14 | 10,50 | 26 | 12,9 | 19,05 | 39,0 | 23,4 | 350 | | 13 | 38 |
| 12 | 16 | 12,00 | 30 | 15,4 | 22,22 | 53,5 | 32,0 | 300 | | 13 | 58 |
| 14 | 19 | 13,50 | 34 | 16,8 | 25,40 | 70,0 | 42,0 | 260 | | 16 | 83 |
| 16 | 21 | 15,00 | 38 | 19,3 | 28,57 | 88,0 | 52,5 | 230 | | 15 | 115 |
| 18 | 23 | 16,50 | 42 | 21,8 | 31,75 | 106,5 | 64,0 | 210 | | 15 | 150 |
| 20 | 25 | 18,00 | 46 | 24,3 | 34,92 | 130,0 | 78,0 | 190 | | 14 | 200 |
| 22 | 28 | 20,00 | 50 | 25,8 | 38,10 | 162,0 | 97,0 | 170 | | 15 | 270 |
| 25 | 31 | 22,00 | 56 | 29,6 | 42,86 | 204,0 | 122,0 | 150 | | 15 | 375 |
| 30 | 37 | 25,00 | 66 | 34,8 | 50,80 | 281,0 | 168,0 | 130 | 17 | 540 | |
| 35 | 43 | 28,00 | 78 | 37,7 | 57,15 | 343,0 | 206,0 | 110 | 19 | 850 | |
| 40 | 49 | 35,00 | 87 | 44,2 | 45,96 | 495,0 | 286,0 | 100 | 16 | 1400 | |

Materials:

Outer ring: Free-cutting steel to 9SMnPb28K, 12L13, turned, galvanised

Insert: Free-cutting steel to 9SMnPb28K, turned, galvanised with PTFE liner bonded to the inner surface

Ball: Bearing steel to 100Cr6, Aisi 52100, hardened, ground, polished

This series is also available with threaded bolt (see page 53).

¹⁾ Outer Ring as one piece to 45S20

Spherical Plain Bearings Series K - Stainless Outer Ring, Maintenance Free

Series GLRSW

Spherical Plain Bearing,
maintenance free

For use at higher
dynamic pressure and
tension loads in
corrosive environments

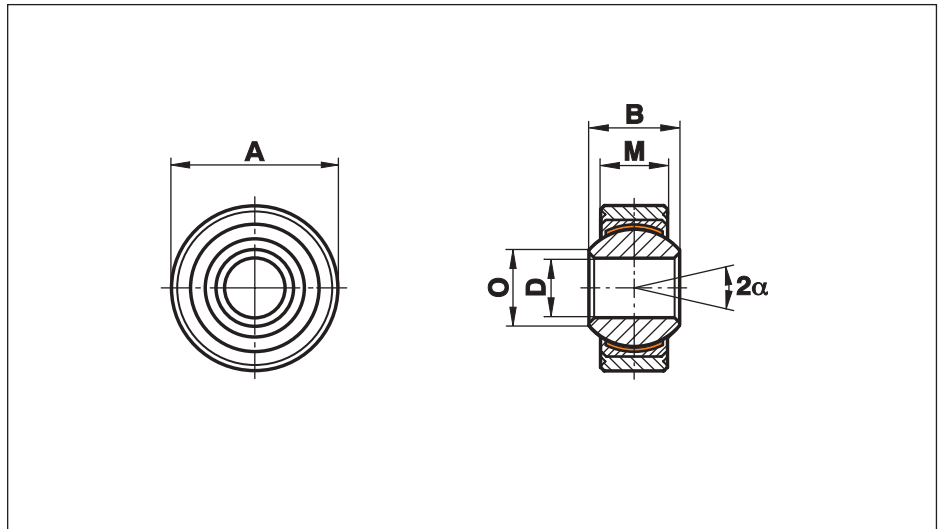

| Size (D H7) | B | M | A (h6) | O | dK | Static load C ₀ kN | Dynamic load C kN | Limiting speed rev/min | Maximum Pivoting Angle α (°) | Weight g | |
|-----------------|----|-------|--------|------|-------|-------------------------------------|-------------------------|------------------------------|---|-------------|-----|
| 4 ¹⁾ | 7 | 5,25 | 14 | 6,5 | 9,52 | 9,5 | 5,7 | 700 | only for short-term revolutions recommended | 14 | 5 |
| 5 | 8 | 6,00 | 16 | 7,7 | 11,11 | 12,5 | 7,5 | 600 | | 13 | 8 |
| 6 | 9 | 6,75 | 18 | 8,9 | 12,70 | 15,5 | 9,3 | 530 | | 13 | 12 |
| 8 | 12 | 9,00 | 22 | 10,4 | 15,87 | 27,8 | 16,7 | 420 | | 14 | 23 |
| 10 | 14 | 10,50 | 26 | 12,9 | 19,05 | 39,0 | 23,4 | 350 | | 13 | 38 |
| 12 | 16 | 12,00 | 30 | 15,4 | 22,22 | 53,5 | 32,0 | 300 | | 13 | 58 |
| 14 | 19 | 13,50 | 34 | 16,8 | 25,40 | 70,0 | 42,0 | 260 | | 16 | 83 |
| 16 | 21 | 15,00 | 38 | 19,3 | 28,57 | 88,0 | 52,5 | 230 | | 15 | 115 |
| 18 | 23 | 16,50 | 42 | 21,8 | 31,75 | 106,5 | 64,0 | 210 | | 15 | 150 |
| 20 | 25 | 18,00 | 46 | 24,3 | 34,92 | 130,0 | 78,0 | 190 | | 14 | 200 |
| 22 | 28 | 20,00 | 50 | 25,8 | 38,10 | 162,0 | 97,0 | 170 | | 15 | 270 |
| 25 | 31 | 22,00 | 56 | 29,6 | 42,86 | 204,0 | 122,0 | 150 | | 15 | 375 |
| 30 | 37 | 25,00 | 66 | 34,8 | 50,80 | 281,0 | 168,0 | 130 | 17 | 540 | |
| 35 | 43 | 28,00 | 78 | 37,7 | 57,15 | 343,0 | 206,0 | 110 | 19 | 850 | |
| 40 | 49 | 35,00 | 87 | 44,2 | 45,96 | 495,0 | 286,0 | 100 | 16 | 1400 | |

Materials:

Outer ring: Stainless steel to 1.4305, Aisi 303, turned

Insert: Special high strength bronze to CuSn8 with PTFE liner bonded to the inner surface

Ball: Bearing steel to 100Cr6, Aisi 52100, hardened, ground, polished, hard chrome plated on the running surface

This series is also available with threaded bolt (see page 53).

¹⁾ Outer Ring stainless steel as one piece to 1.4305, Aisi303

Spherical Plain Bearings Series K - Stainless, Maintenance Free

Series GLRSW..R

Spherical Plain Bearing,
maintenance free

For use at higher
dynamic pressure and
tension loads in
corrosive environments

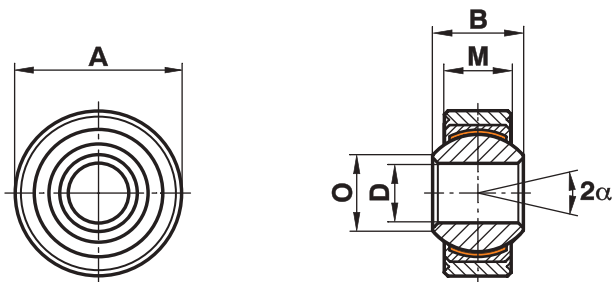

| Size (D H7) | B | M | A (h6) | O | dK | Static load C ₀ kN | Dynamic load C kN | Limiting speed rev/min | Maximum Pivoting Angle α (°) | Weight g | |
|-----------------|----|-------|--------|------|-------|-------------------------------------|-------------------------|------------------------------|--|-------------|-----|
| 4 ¹⁾ | 7 | 5,25 | 14 | 6,5 | 9,52 | 9,5 | 5,7 | 700 | only for short-term revolutions recommended | 14 | 5 |
| 5 | 8 | 6,00 | 16 | 7,7 | 11,11 | 12,5 | 7,5 | 600 | | 13 | 8 |
| 6 | 9 | 6,75 | 18 | 8,9 | 12,70 | 15,5 | 9,3 | 530 | | 13 | 12 |
| 8 | 12 | 9,00 | 22 | 10,4 | 15,87 | 27,8 | 16,7 | 420 | | 14 | 23 |
| 10 | 14 | 10,50 | 26 | 12,9 | 19,05 | 39,0 | 23,4 | 350 | | 13 | 38 |
| 12 | 16 | 12,00 | 30 | 15,4 | 22,22 | 53,5 | 32,0 | 300 | | 13 | 58 |
| 14 | 19 | 13,50 | 34 | 16,8 | 25,40 | 70,0 | 42,0 | 260 | | 16 | 83 |
| 16 | 21 | 15,00 | 38 | 19,3 | 28,57 | 88,0 | 52,5 | 230 | | 15 | 115 |
| 18 | 23 | 16,50 | 42 | 21,8 | 31,75 | 106,5 | 64,0 | 210 | | 15 | 150 |
| 20 | 25 | 18,00 | 46 | 24,3 | 34,92 | 130,0 | 78,0 | 190 | | 14 | 200 |
| 22 | 28 | 20,00 | 50 | 25,8 | 38,10 | 162,0 | 97,0 | 170 | | 15 | 270 |
| 25 | 31 | 22,00 | 56 | 29,6 | 42,86 | 204,0 | 122,0 | 150 | | 15 | 375 |
| 30 | 37 | 25,00 | 66 | 34,8 | 50,80 | 281,0 | 168,0 | 130 | 17 | 540 | |
| 35 | 43 | 28,00 | 78 | 37,7 | 57,15 | 343,0 | 206,0 | 110 | 19 | 850 | |
| 40 | 49 | 35,00 | 87 | 44,2 | 45,96 | 495,0 | 286,0 | 100 | 16 | 1400 | |

Materials:

Outer ring: Stainless steel to 1.4305, Aisi 303, turned

Insert: Special high strength bronze to CuSn8 with PTFE liner bonded to the inner surface

Ball: Stainless steel to 1.4034, hardened, ground, polished

This series is also available with threaded bolt (see page 53).

¹⁾ Outer Ring stainless steel as one piece to 1.4305, Aisi 303

Spherical Plain Bearings Series K - Stainless, Maintenance Free

Series

GLRSW..RR

Spherical Plain Bearing,
maintenance free

For use at higher
dynamic pressure and
tension loads in
corrosive environments

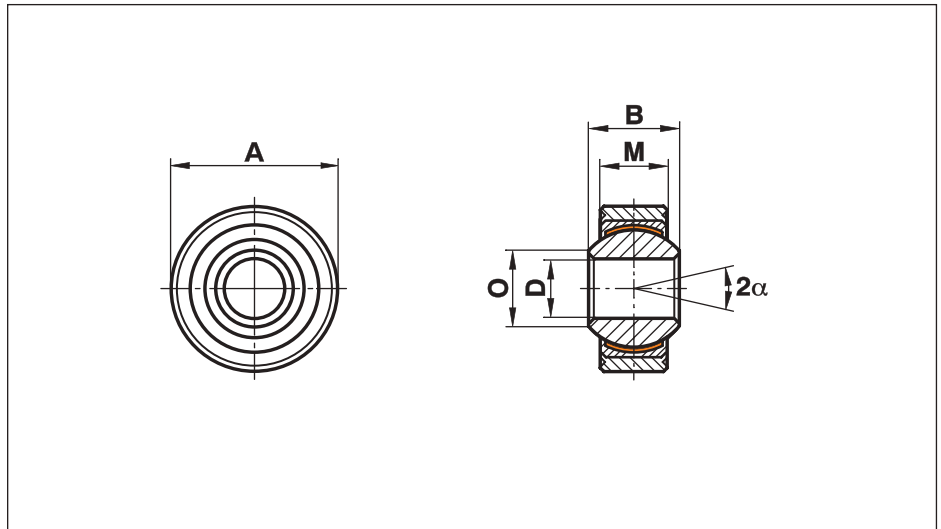

| Size (D H7) | B | M | A (h6) | O | dK | Static load C ₀ kN | Dynamic load C kN | Limiting speed rev/min | Maximum Pivoting Angle α (°) | Weight g | |
|-----------------|----|-------|--------|------|-------|-------------------------------------|-------------------------|------------------------------|--|-------------|-----|
| 4 ¹⁾ | 7 | 5,25 | 14 | 6,5 | 9,52 | 9,5 | 5,7 | 700 | only for short-term revolutions recommended | 14 | 5 |
| 5 | 8 | 6,00 | 16 | 7,7 | 11,11 | 12,5 | 7,5 | 600 | | 13 | 8 |
| 6 | 9 | 6,75 | 18 | 8,9 | 12,70 | 15,5 | 9,3 | 530 | | 13 | 12 |
| 8 | 12 | 9,00 | 22 | 10,4 | 15,87 | 27,8 | 16,7 | 420 | | 14 | 23 |
| 10 | 14 | 10,50 | 26 | 12,9 | 19,05 | 39,0 | 23,4 | 350 | | 13 | 38 |
| 12 | 16 | 12,00 | 30 | 15,4 | 22,22 | 53,5 | 32,0 | 300 | | 13 | 58 |
| 14 | 19 | 13,50 | 34 | 16,8 | 25,40 | 70,0 | 42,0 | 260 | | 16 | 83 |
| 16 | 21 | 15,00 | 38 | 19,3 | 28,57 | 88,0 | 52,5 | 230 | | 15 | 115 |
| 18 | 23 | 16,50 | 42 | 21,8 | 31,75 | 106,5 | 64,0 | 210 | | 15 | 150 |
| 20 | 25 | 18,00 | 46 | 24,3 | 34,92 | 130,0 | 78,0 | 190 | | 14 | 200 |
| 22 | 28 | 20,00 | 50 | 25,8 | 38,10 | 162,0 | 97,0 | 170 | | 15 | 270 |
| 25 | 31 | 22,00 | 56 | 29,6 | 42,86 | 204,0 | 122,0 | 150 | | 15 | 375 |
| 30 | 37 | 25,00 | 66 | 34,8 | 50,80 | 281,0 | 168,0 | 130 | 17 | 540 | |
| 35 | 43 | 28,00 | 78 | 37,7 | 57,15 | 343,0 | 206,0 | 110 | 19 | 850 | |
| 40 | 49 | 35,00 | 87 | 44,2 | 45,96 | 495,0 | 286,0 | 100 | 16 | 1400 | |

Materials:

Outer ring: Stainless steel to 1.4305, Aisi 303, turned

Insert: Stainless steel to 1.4571 with PTFE liner bonded to the inner surface

Ball: Stainless steel to 1.4034, hardened, ground, polished

This series is also available with threaded bolt (see page 53).

1) Outer Ring stainless steel as one piece to 1.4305, Aisi 303

Spherical Plain Bearings Series K - Stainless, Maintenance Free

Series

GLRSW..RR.316

Spherical Plain Bearing,
maintenance free

For use at higher
dynamic pressure and
tension loads in
corrosive environments

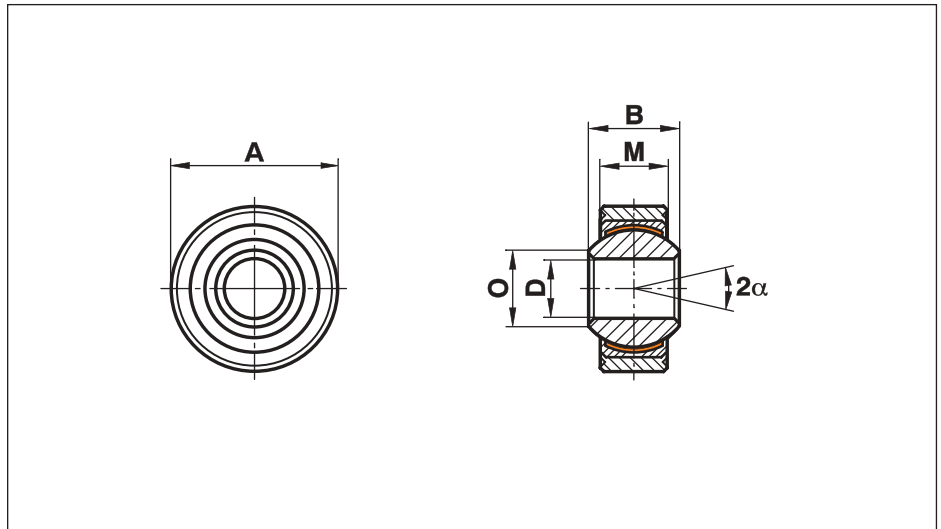

| Size (D H7) | B | M | A (h6) | O | dK | Static load C ₀ kN | Dynamic load C kN | Limiting speed rev/min | Maximum Pivoting Angle α (°) | Weight g | |
|-----------------|----|-------|--------|------|-------|-------------------------------------|-------------------------|------------------------------|--|-------------|-----|
| 4 ¹⁾ | 7 | 5,25 | 14 | 6,5 | 9,52 | 9,5 | 5,7 | 700 | only for short-term revolutions recommended | 14 | 5 |
| 5 | 8 | 6,00 | 16 | 7,7 | 11,11 | 12,5 | 7,5 | 600 | | 13 | 8 |
| 6 | 9 | 6,75 | 18 | 8,9 | 12,70 | 15,5 | 9,3 | 530 | | 13 | 12 |
| 8 | 12 | 9,00 | 22 | 10,4 | 15,87 | 27,8 | 16,7 | 420 | | 14 | 23 |
| 10 | 14 | 10,50 | 26 | 12,9 | 19,05 | 39,0 | 23,4 | 350 | | 13 | 38 |
| 12 | 16 | 12,00 | 30 | 15,4 | 22,22 | 53,5 | 32,0 | 300 | | 13 | 58 |
| 14 | 19 | 13,50 | 34 | 16,8 | 25,40 | 70,0 | 42,0 | 260 | | 16 | 83 |
| 16 | 21 | 15,00 | 38 | 19,3 | 28,57 | 88,0 | 52,5 | 230 | | 15 | 115 |
| 18 | 23 | 16,50 | 42 | 21,8 | 31,75 | 106,5 | 64,0 | 210 | | 15 | 150 |
| 20 | 25 | 18,00 | 46 | 24,3 | 34,92 | 130,0 | 78,0 | 190 | | 14 | 200 |
| 22 | 28 | 20,00 | 50 | 25,8 | 38,10 | 162,0 | 97,0 | 170 | | 15 | 270 |
| 25 | 31 | 22,00 | 56 | 29,6 | 42,86 | 204,0 | 122,0 | 150 | | 15 | 375 |
| 30 | 37 | 25,00 | 66 | 34,8 | 50,80 | 281,0 | 168,0 | 130 | 17 | 540 | |
| 35 | 43 | 28,00 | 78 | 37,7 | 57,15 | 343,0 | 206,0 | 110 | 19 | 850 | |
| 40 | 49 | 35,00 | 87 | 44,2 | 45,96 | 495,0 | 286,0 | 100 | 16 | 1400 | |

Materials:

Outer ring: Stainless steel to 1.4305, Aisi 303, turned

Insert: Stainless steel 1.4571 with PTFE liner bonded to the inner surface

Ball: Stainless steel to 1.4404, Aisi 316 ground, polished

This series is also available with threaded bolt (see page 53).

¹⁾ Outer Ring stainless steel as one piece to 1.4305, Aisi 303

Spherical Plain Bearings Series K - Heavy Duty

Series GXS

Spherical Plain Bearing,
regreasable

For use at high revs

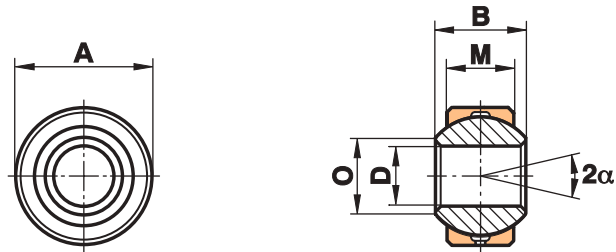

| Size (D H7) | B | M | A (h6) | O | dK | Static load C ₀ kN | Dynamic load C kN | Limiting speed rev/min | Maximum Pivoting Angle α (°) | Weight g |
|-----------------|------|-------|--------|------|-------|-------------------------------|-------------------|------------------------|------------------------------|----------|
| 2 ¹⁾ | 4,5 | 3,60 | 6,5 | 2,6 | 5,20 | 6,6 | 1,1 | | 16 | 3 |
| 3 ¹⁾ | 6,0 | 4,50 | 9,0 | 5,1 | 7,94 | 10,8 | 1,8 | | 14 | 4 |
| 4 ¹⁾ | 7,0 | 5,25 | 12,0 | 6,5 | 9,52 | 14,5 | 2,5 | | 14 | 4 |
| 5 ¹⁾ | 8,0 | 6,00 | 13,0 | 7,7 | 11,11 | 19,8 | 3,3 | | 13 | 5 |
| 6 | 9,0 | 6,75 | 15,0 | 8,9 | 12,70 | 25,8 | 4,3 | 1500 | 13 | 8 |
| 6.16 | 9,0 | 6,75 | 16,0 | 8,9 | 12,70 | 25,8 | 4,3 | 1500 | 13 | 9 |
| 8 | 12,0 | 9,00 | 18,0 | 10,4 | 15,87 | 42,6 | 7,1 | 1200 | 14 | 14 |
| 8.19 | 12,0 | 9,00 | 19,0 | 10,4 | 15,87 | 42,6 | 7,1 | 1200 | 14 | 16 |
| 10 | 14,0 | 10,50 | 21,0 | 12,9 | 19,05 | 60,0 | 10,0 | 1000 | 13 | 22 |
| 10.22 | 14,0 | 10,50 | 22,0 | 12,9 | 19,05 | 60,0 | 10,0 | 1000 | 13 | 25 |
| 12 | 16,0 | 12,00 | 24,5 | 15,4 | 22,22 | 80,0 | 13,5 | 860 | 13 | 35 |
| 12.26 | 16,0 | 12,00 | 26,0 | 15,4 | 22,22 | 80,0 | 13,5 | 860 | 13 | 40 |
| 14 | 19,0 | 13,50 | 28,0 | 16,8 | 25,40 | 102,5 | 17,0 | 750 | 16 | 51 |
| 14.29 | 19,0 | 13,50 | 29,0 | 16,8 | 25,40 | 102,5 | 17,0 | 750 | 16 | 56 |
| 16 | 21,0 | 15,00 | 31,5 | 19,3 | 28,57 | 128,5 | 21,5 | 660 | 15 | 72 |
| 16.32 | 21,0 | 15,00 | 32,0 | 19,3 | 28,57 | 128,5 | 21,5 | 660 | 15 | 76 |
| 18 | 23,0 | 16,50 | 34,5 | 21,8 | 31,75 | 157,0 | 26,0 | 600 | 15 | 94 |
| 18.35 | 23,0 | 16,50 | 35,0 | 21,8 | 31,75 | 157,0 | 26,0 | 600 | 15 | 97 |
| 20 | 25,0 | 18,00 | 38,0 | 24,3 | 34,92 | 188,5 | 31,5 | 540 | 14 | 124 |
| 20.40 | 25,0 | 18,00 | 40,0 | 24,3 | 34,92 | 188,5 | 31,5 | 540 | 14 | 141 |
| 22 | 28,0 | 20,00 | 41,0 | 25,8 | 38,10 | 229,0 | 38,0 | 500 | 15 | 158 |
| 22.42 | 28,0 | 20,00 | 42,0 | 25,8 | 38,10 | 229,0 | 38,0 | 500 | 15 | 168 |
| 25 | 31,0 | 22,00 | 46,0 | 29,6 | 42,86 | 293,0 | 47,0 | 440 | 15 | 218 |
| 25.47 | 31,0 | 22,00 | 47,0 | 29,6 | 42,86 | 293,0 | 47,0 | 440 | 15 | 231 |
| 30 | 37,0 | 25,00 | 54,0 | 34,8 | 50,80 | 381,0 | 64,0 | 370 | 17 | 349 |
| 30.55 | 37,0 | 25,00 | 55,0 | 34,8 | 50,80 | 381,0 | 64,0 | 370 | 17 | 362 |
| 35 | 43,0 | 28,00 | 62,0 | 37,7 | 57,15 | 480,0 | 80,0 | 330 | 19 | 502 |
| 35.65 | 43,0 | 28,00 | 65,0 | 37,7 | 57,15 | 480,0 | 80,0 | 330 | 19 | 518 |
| 40 | 49,0 | 35,00 | 72,0 | 44,2 | 65,96 | 693,0 | 116,0 | 290 | 16 | 832 |
| 40.75 | 49,0 | 35,00 | 75,0 | 44,2 | 65,96 | 693,0 | 116,0 | 290 | 16 | 850 |
| 50 | 60,0 | 45,00 | 90,0 | 55,9 | 82,00 | 1100,0 | 185,0 | 230 | 14 | 1600 |

only for short-term revolutions recommended

Materials:

Insert: Special high strength bronze to CuSn8

Ball: Bearing steel to 100Cr6, Aisi 52100, hardened, ground, polished

This series is also available with threaded bolt (see page 53).

¹⁾ without lubrication hole

Spherical Plain Bearings Series K - Stainless Ball, requiring maintenance

Series GXS..R

Spherical Plain Bearing,
regreasable

For use at high revs

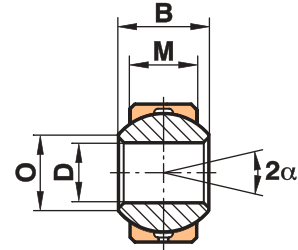
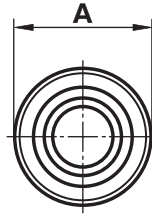

| Size (D H7) | B | M | A (h6) | O | dK | Static load C ₀ kN | Dynamic load C kN | Limiting speed rev/min | Maximum Pivoting Angle α (°) | Weight g |
|-----------------|------|-------|--------|------|-------|-------------------------------|-------------------|------------------------|------------------------------|----------|
| 2 ¹⁾ | 4,5 | 3,60 | 6,5 | 2,6 | 5,20 | 6,6 | 1,1 | | 16 | 3 |
| 3 ¹⁾ | 6,0 | 4,50 | 9,0 | 5,1 | 7,94 | 10,8 | 1,8 | | 14 | 4 |
| 4 ¹⁾ | 7,0 | 5,25 | 12,0 | 6,5 | 9,52 | 14,5 | 2,5 | | 14 | 4 |
| 5 ¹⁾ | 8,0 | 6,00 | 13,0 | 7,7 | 11,11 | 19,8 | 3,3 | | 13 | 5 |
| 6 | 9,0 | 6,75 | 15,0 | 8,9 | 12,70 | 25,8 | 4,3 | 1500 | 13 | 8 |
| 6.16 | 9,0 | 6,75 | 16,0 | 8,9 | 12,70 | 25,8 | 4,3 | 1500 | 13 | 9 |
| 8 | 12,0 | 9,00 | 18,0 | 10,4 | 15,87 | 42,6 | 7,1 | 1200 | 14 | 14 |
| 8.19 | 12,0 | 9,00 | 19,0 | 10,4 | 15,87 | 42,6 | 7,1 | 1200 | 14 | 16 |
| 10 | 14,0 | 10,50 | 21,0 | 12,9 | 19,05 | 60,0 | 10,0 | 1000 | 13 | 22 |
| 10.22 | 14,0 | 10,50 | 22,0 | 12,9 | 19,05 | 60,0 | 10,0 | 1000 | 13 | 25 |
| 12 | 16,0 | 12,00 | 24,5 | 15,4 | 22,22 | 80,0 | 13,5 | 860 | 13 | 35 |
| 12.26 | 16,0 | 12,00 | 26,0 | 15,4 | 22,22 | 80,0 | 13,5 | 860 | 13 | 40 |
| 14 | 19,0 | 13,50 | 28,0 | 16,8 | 25,40 | 102,5 | 17,0 | 750 | 16 | 51 |
| 14.29 | 19,0 | 13,50 | 29,0 | 16,8 | 25,40 | 102,5 | 17,0 | 750 | 16 | 56 |
| 16 | 21,0 | 15,00 | 31,5 | 19,3 | 28,57 | 128,5 | 21,5 | 660 | 15 | 72 |
| 16.32 | 21,0 | 15,00 | 32,0 | 19,3 | 28,57 | 128,5 | 21,5 | 660 | 15 | 76 |
| 18 | 23,0 | 16,50 | 34,5 | 21,8 | 31,75 | 157,0 | 26,0 | 600 | 15 | 94 |
| 18.35 | 23,0 | 16,50 | 35,0 | 21,8 | 31,75 | 157,0 | 26,0 | 600 | 15 | 97 |
| 20 | 25,0 | 18,00 | 38,0 | 24,3 | 34,92 | 188,5 | 31,5 | 540 | 14 | 124 |
| 20.40 | 25,0 | 18,00 | 40,0 | 24,3 | 34,92 | 188,5 | 31,5 | 540 | 14 | 141 |
| 22 | 28,0 | 20,00 | 41,0 | 25,8 | 38,10 | 229,0 | 38,0 | 500 | 15 | 158 |
| 22.42 | 28,0 | 20,00 | 42,0 | 25,8 | 38,10 | 229,0 | 38,0 | 500 | 15 | 168 |
| 25 | 31,0 | 22,00 | 46,0 | 29,6 | 42,86 | 293,0 | 47,0 | 440 | 15 | 218 |
| 25.47 | 31,0 | 22,00 | 47,0 | 29,6 | 42,86 | 293,0 | 47,0 | 440 | 15 | 231 |
| 30 | 37,0 | 25,00 | 54,0 | 34,8 | 50,80 | 381,0 | 64,0 | 370 | 17 | 349 |
| 30.55 | 37,0 | 25,00 | 55,0 | 34,8 | 50,80 | 381,0 | 64,0 | 370 | 17 | 362 |
| 35 | 43,0 | 28,00 | 62,0 | 37,7 | 57,15 | 480,0 | 80,0 | 330 | 19 | 502 |
| 35.65 | 43,0 | 28,00 | 65,0 | 37,7 | 57,15 | 480,0 | 80,0 | 330 | 19 | 518 |
| 40 | 49,0 | 35,00 | 72,0 | 44,2 | 65,96 | 693,0 | 116,0 | 290 | 16 | 832 |
| 40.75 | 49,0 | 35,00 | 75,0 | 44,2 | 65,96 | 693,0 | 116,0 | 290 | 16 | 850 |
| 50 | 60,0 | 45,00 | 90,0 | 55,9 | 82,00 | 1100,0 | 185,0 | 230 | 14 | 1600 |

only for short-term revolutions recommended

Materials:

Insert: Special high strength bronze to CuSn8

Ball: Stainless steel to 1.4034, hardened, ground, polished

This series is also available with threaded bolt (see page 53).

¹⁾ without lubrication hole

Spherical Plain Bearings Series K - Maintenance Free

Series GXSW

Spherical Plain Bearing,
maintenance free

For use at high pressure
and dynamic loads

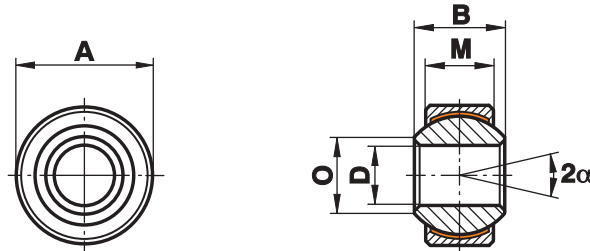

| Size | D (H7) | B | M | A (h6) | O | dK | Static load C ₀ kN | Dynamic load C kN | Limiting speed rev/min | Maximum Pivoting Angle α (°) | Weight g |
|-------|--------|----|-------|--------|------|-------|-------------------------------|-------------------|------------------------|------------------------------|----------|
| 4 | 4 | 7 | 5,25 | 12,0 | 6,5 | 9,52 | 8,5 | 5,1 | 700 | 14 | 4 |
| 5 | 5 | 8 | 6,00 | 13,0 | 7,7 | 11,11 | 12,5 | 7,5 | 600 | 13 | 6 |
| 6 | 6 | 9 | 6,75 | 15,0 | 8,9 | 12,70 | 15,5 | 9,3 | 530 | 13 | 8 |
| 6.16 | 6 | 9 | 6,75 | 16,0 | 8,9 | 12,70 | 15,5 | 9,3 | 530 | 13 | 9 |
| 8 | 8 | 12 | 9,00 | 18,0 | 10,4 | 15,87 | 27,8 | 16,7 | 420 | 14 | 15 |
| 8.19 | 8 | 12 | 9,00 | 19,0 | 10,4 | 15,87 | 27,8 | 16,7 | 420 | 14 | 17 |
| 10 | 10 | 14 | 10,50 | 21,0 | 12,9 | 19,05 | 39,0 | 23,4 | 350 | 13 | 23 |
| 10.22 | 10 | 14 | 10,50 | 22,0 | 12,9 | 19,05 | 39,0 | 23,4 | 350 | 13 | 26 |
| 12 | 12 | 16 | 12,00 | 24,5 | 15,4 | 22,22 | 53,5 | 32,0 | 300 | 13 | 35 |
| 12.26 | 12 | 16 | 12,00 | 26,0 | 15,4 | 22,22 | 53,5 | 32,0 | 300 | 13 | 41 |
| 14 | 14 | 19 | 13,50 | 28,0 | 16,8 | 25,40 | 70,0 | 42,0 | 260 | 16 | 52 |
| 14.29 | 14 | 19 | 13,50 | 29,0 | 16,8 | 25,40 | 70,0 | 42,0 | 260 | 16 | 56 |
| 16 | 16 | 21 | 15,00 | 31,5 | 19,3 | 28,57 | 88,0 | 52,5 | 230 | 15 | 72 |
| 16.32 | 16 | 21 | 15,00 | 32,0 | 19,3 | 28,57 | 88,0 | 52,5 | 230 | 15 | 75 |
| 18 | 18 | 23 | 16,50 | 34,5 | 21,8 | 31,75 | 106,5 | 64,0 | 210 | 15 | 95 |
| 18.35 | 18 | 23 | 16,50 | 35,0 | 21,8 | 31,75 | 106,5 | 64,0 | 210 | 15 | 97 |
| 20 | 20 | 25 | 18,00 | 38,0 | 24,3 | 34,92 | 130,0 | 78,0 | 190 | 14 | 127 |
| 20.40 | 20 | 25 | 18,00 | 40,0 | 24,3 | 34,92 | 130,0 | 78,0 | 190 | 14 | 142 |
| 22 | 22 | 28 | 20,00 | 41,0 | 25,8 | 38,10 | 162,0 | 97,0 | 170 | 15 | 159 |
| 22.42 | 22 | 28 | 20,00 | 42,0 | 25,8 | 38,10 | 162,0 | 97,0 | 170 | 15 | 169 |
| 25 | 25 | 31 | 22,00 | 46,0 | 29,6 | 42,86 | 204,0 | 122,0 | 150 | 15 | 222 |
| 25.47 | 25 | 31 | 22,00 | 47,0 | 29,6 | 42,86 | 204,0 | 122,0 | 150 | 15 | 230 |
| 30 | 30 | 37 | 25,00 | 54,0 | 34,8 | 50,80 | 281,0 | 168,0 | 130 | 17 | 350 |
| 30.55 | 30 | 37 | 25,00 | 55,0 | 34,8 | 50,80 | 281,0 | 168,0 | 130 | 17 | 369 |
| 35 | 35 | 43 | 28,00 | 62,0 | 37,7 | 57,15 | 343,0 | 206,0 | 110 | 19 | 505 |
| 35.65 | 35 | 43 | 28,00 | 65,0 | 37,7 | 57,15 | 343,0 | 206,0 | 110 | 19 | 545 |
| 40 | 40 | 49 | 35,00 | 72,0 | 44,2 | 65,96 | 495,0 | 286,0 | 100 | 16 | 832 |
| 40.75 | 40 | 49 | 35,00 | 75,0 | 44,2 | 65,96 | 495,0 | 286,0 | 100 | 16 | 894 |
| 50 | 50 | 60 | 45,00 | 90,0 | 55,9 | 82,00 | 800,0 | 485,0 | 80 | 14 | 1640 |

only for short-term revolutions recommended

Materials:

Insert: Free-cutting steel to 9SMnPb28K, 12L13, galvanised, with PTFE liner bonded to inner surface
Ball: Bearing steel to 100Cr6, Aisi 52100, hardened, ground, polished

This series is also available with threaded bolt (see page 53).

Spherical Plain Bearings Series K -Stainless Ball, Maintenance Free

Series GXSW..R

Spherical Plain Bearing,
maintenance free

For use at high pressure
and dynamic loads in
corrosive environments

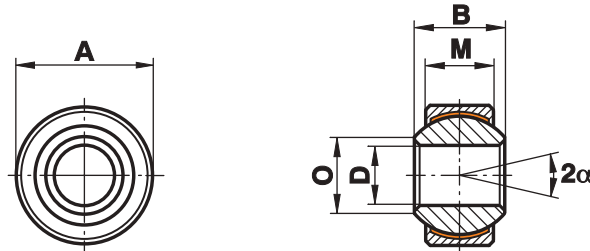

| Size | D (H7) | B | M | A (h6) | O | dK | Static load C ₀ kN | Dynamic load C kN | Limiting speed rev/min | Maximum Pivoting Angle α (°) | Weight g |
|-------|--------|----|-------|--------|------|-------|-------------------------------|-------------------|------------------------|------------------------------|----------|
| 4 | 4 | 7 | 5,25 | 12,0 | 6,5 | 9,52 | 8,5 | 5,1 | 700 | 14 | 4 |
| 5 | 5 | 8 | 6,00 | 13,0 | 7,7 | 11,11 | 12,5 | 7,5 | 600 | 13 | 6 |
| 6 | 6 | 9 | 6,75 | 15,0 | 8,9 | 12,70 | 15,5 | 9,3 | 530 | 13 | 8 |
| 6.16 | 6 | 9 | 6,75 | 16,0 | 8,9 | 12,70 | 15,5 | 9,3 | 530 | 13 | 9 |
| 8 | 8 | 12 | 9,00 | 18,0 | 10,4 | 15,87 | 27,8 | 16,7 | 420 | 14 | 15 |
| 8.19 | 8 | 12 | 9,00 | 19,0 | 10,4 | 15,87 | 27,8 | 16,7 | 420 | 14 | 17 |
| 10 | 10 | 14 | 10,50 | 21,0 | 12,9 | 19,05 | 39,0 | 23,4 | 350 | 13 | 23 |
| 10.22 | 10 | 14 | 10,50 | 22,0 | 12,9 | 19,05 | 39,0 | 23,4 | 350 | 13 | 26 |
| 12 | 12 | 16 | 12,00 | 24,5 | 15,4 | 22,22 | 53,5 | 32,0 | 300 | 13 | 35 |
| 12.26 | 12 | 16 | 12,00 | 26,0 | 15,4 | 22,22 | 53,5 | 32,0 | 300 | 13 | 41 |
| 14 | 14 | 19 | 13,50 | 28,0 | 16,8 | 25,40 | 70,0 | 42,0 | 260 | 16 | 52 |
| 14.29 | 14 | 19 | 13,50 | 29,0 | 16,8 | 25,40 | 70,0 | 42,0 | 260 | 16 | 56 |
| 16 | 16 | 21 | 15,00 | 31,5 | 19,3 | 28,57 | 88,0 | 52,5 | 230 | 15 | 72 |
| 16.32 | 16 | 21 | 15,00 | 32,0 | 19,3 | 28,57 | 88,0 | 52,5 | 230 | 15 | 75 |
| 18 | 18 | 23 | 16,50 | 34,5 | 21,8 | 31,75 | 106,5 | 64,0 | 210 | 15 | 95 |
| 18.35 | 18 | 23 | 16,50 | 35,0 | 21,8 | 31,75 | 106,5 | 64,0 | 210 | 15 | 97 |
| 20 | 20 | 25 | 18,00 | 38,0 | 24,3 | 34,92 | 130,0 | 78,0 | 190 | 14 | 127 |
| 20.40 | 20 | 25 | 18,00 | 40,0 | 24,3 | 34,92 | 130,0 | 78,0 | 190 | 14 | 142 |
| 22 | 22 | 28 | 20,00 | 41,0 | 25,8 | 38,10 | 162,0 | 97,0 | 170 | 15 | 159 |
| 22.42 | 22 | 28 | 20,00 | 42,0 | 25,8 | 38,10 | 162,0 | 97,0 | 170 | 15 | 169 |
| 25 | 25 | 31 | 22,00 | 46,0 | 29,6 | 42,86 | 204,0 | 122,0 | 150 | 15 | 222 |
| 25.47 | 25 | 31 | 22,00 | 47,0 | 29,6 | 42,86 | 204,0 | 122,0 | 150 | 15 | 230 |
| 30 | 30 | 37 | 25,00 | 54,0 | 34,8 | 50,80 | 281,0 | 168,0 | 130 | 17 | 350 |
| 30.55 | 30 | 37 | 25,00 | 55,0 | 34,8 | 50,80 | 281,0 | 168,0 | 130 | 17 | 369 |
| 35 | 35 | 43 | 28,00 | 62,0 | 37,7 | 57,15 | 343,0 | 206,0 | 110 | 19 | 505 |
| 35.65 | 35 | 43 | 28,00 | 65,0 | 37,7 | 57,15 | 343,0 | 206,0 | 110 | 19 | 545 |
| 40 | 40 | 49 | 35,00 | 72,0 | 44,2 | 65,96 | 495,0 | 286,0 | 100 | 16 | 832 |
| 40.75 | 40 | 49 | 35,00 | 75,0 | 44,2 | 65,96 | 495,0 | 286,0 | 100 | 16 | 894 |
| 50 | 50 | 60 | 45,00 | 90,0 | 55,9 | 82,00 | 800,0 | 485,0 | 80 | 14 | 1640 |

only for short-term revolutions recommended

Materials:

Insert: Special high strength bronze to CuSn8 with PTFE liner bonded to the inner surface
Ball: Stainless steel to 1.4034, hardened, ground, polished

This series is also available with threaded bolt (see page 53).

Spherical Plain Bearings Series K -Stainless, Maintenance Free

Series

GXSW..RR

Spherical Plain Bearing,
maintenance free

For use at high pressure
and dynamic loads in
corrosive environments

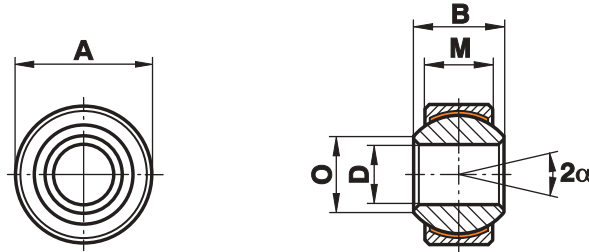

| Size | D (H7) | B | M | A (h6) | O | dK | Static load C ₀ kN | Dynamic load C kN | Limiting speed rev/min | Maximum Pivoting Angle α (°) | Weight g |
|-------|--------|----|-------|--------|------|-------|-------------------------------|-------------------|------------------------|------------------------------|----------|
| 4 | 4 | 7 | 5,25 | 12,0 | 6,5 | 9,52 | 8,5 | 5,1 | 700 | 14 | 4 |
| 5 | 5 | 8 | 6,00 | 13,0 | 7,7 | 11,11 | 12,5 | 7,5 | 600 | 13 | 6 |
| 6 | 6 | 9 | 6,75 | 15,0 | 8,9 | 12,70 | 15,5 | 9,3 | 530 | 13 | 8 |
| 6.16 | 6 | 9 | 6,75 | 16,0 | 8,9 | 12,70 | 15,5 | 9,3 | 530 | 13 | 9 |
| 8 | 8 | 12 | 9,00 | 18,0 | 10,4 | 15,87 | 27,8 | 16,7 | 420 | 14 | 15 |
| 8.19 | 8 | 12 | 9,00 | 19,0 | 10,4 | 15,87 | 27,8 | 16,7 | 420 | 14 | 17 |
| 10 | 10 | 14 | 10,50 | 21,0 | 12,9 | 19,05 | 39,0 | 23,4 | 350 | 13 | 23 |
| 10.22 | 10 | 14 | 10,50 | 22,0 | 12,9 | 19,05 | 39,0 | 23,4 | 350 | 13 | 26 |
| 12 | 12 | 16 | 12,00 | 24,5 | 15,4 | 22,22 | 53,5 | 32,0 | 300 | 13 | 35 |
| 12.26 | 12 | 16 | 12,00 | 26,0 | 15,4 | 22,22 | 53,5 | 32,0 | 300 | 13 | 41 |
| 14 | 14 | 19 | 13,50 | 28,0 | 16,8 | 25,40 | 70,0 | 42,0 | 260 | 16 | 52 |
| 14.29 | 14 | 19 | 13,50 | 29,0 | 16,8 | 25,40 | 70,0 | 42,0 | 260 | 16 | 56 |
| 16 | 16 | 21 | 15,00 | 31,5 | 19,3 | 28,57 | 88,0 | 52,5 | 230 | 15 | 72 |
| 16.32 | 16 | 21 | 15,00 | 32,0 | 19,3 | 28,57 | 88,0 | 52,5 | 230 | 15 | 75 |
| 18 | 18 | 23 | 16,50 | 34,5 | 21,8 | 31,75 | 106,5 | 64,0 | 210 | 15 | 95 |
| 18.35 | 18 | 23 | 16,50 | 35,0 | 21,8 | 31,75 | 106,5 | 64,0 | 210 | 15 | 97 |
| 20 | 20 | 25 | 18,00 | 38,0 | 24,3 | 34,92 | 130,0 | 78,0 | 190 | 14 | 127 |
| 20.40 | 20 | 25 | 18,00 | 40,0 | 24,3 | 34,92 | 130,0 | 78,0 | 190 | 14 | 142 |
| 22 | 22 | 28 | 20,00 | 41,0 | 25,8 | 38,10 | 162,0 | 97,0 | 170 | 15 | 159 |
| 22.42 | 22 | 28 | 20,00 | 42,0 | 25,8 | 38,10 | 162,0 | 97,0 | 170 | 15 | 169 |
| 25 | 25 | 31 | 22,00 | 46,0 | 29,6 | 42,86 | 204,0 | 122,0 | 150 | 15 | 222 |
| 25.47 | 25 | 31 | 22,00 | 47,0 | 29,6 | 42,86 | 204,0 | 122,0 | 150 | 15 | 230 |
| 30 | 30 | 37 | 25,00 | 54,0 | 34,8 | 50,80 | 281,0 | 168,0 | 130 | 17 | 350 |
| 30.55 | 30 | 37 | 25,00 | 55,0 | 34,8 | 50,80 | 281,0 | 168,0 | 130 | 17 | 369 |
| 35 | 35 | 43 | 28,00 | 62,0 | 37,7 | 57,15 | 343,0 | 206,0 | 110 | 19 | 505 |
| 35.65 | 35 | 43 | 28,00 | 65,0 | 37,7 | 57,15 | 343,0 | 206,0 | 110 | 19 | 545 |
| 40 | 40 | 49 | 35,00 | 72,0 | 44,2 | 65,96 | 495,0 | 286,0 | 100 | 16 | 832 |
| 40.75 | 40 | 49 | 35,00 | 75,0 | 44,2 | 65,96 | 495,0 | 286,0 | 100 | 16 | 894 |
| 50 | 50 | 60 | 45,00 | 90,0 | 55,9 | 82,00 | 800,0 | 485,0 | 80 | 14 | 1640 |

only for short-term revolutions recommended

Materials:

Insert: Stainless steel to 1.4571 with PTFE liner bonded to the inner surface
Ball: Stainless steel to 1.4034, hardened, ground, polished

This series is also available with threaded bolt (see page 53).

Spherical Plain Bearings Series K -Stainless, Maintenance Free

Series

GXSW..RR.316

Spherical Plain Bearing,
maintenance free

For use at high pressure
and dynamic loads in
corrosive environments

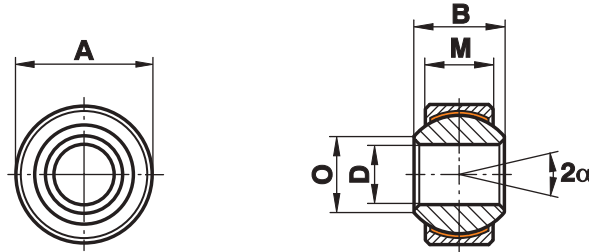

| Size | D (H7) | B | M | A (h6) | O | dK | Static load C ₀ kN | Dynamic load C kN | Limiting speed rev/min | Maximum Pivoting Angle α (°) | Weight g |
|-------|--------|----|-------|--------|------|-------|-------------------------------|-------------------|------------------------|------------------------------|----------|
| 4 | 4 | 7 | 5,25 | 12,0 | 6,5 | 9,52 | 8,5 | 5,1 | 700 | 14 | 4 |
| 5 | 5 | 8 | 6,00 | 13,0 | 7,7 | 11,11 | 12,5 | 7,5 | 600 | 13 | 6 |
| 6 | 6 | 9 | 6,75 | 15,0 | 8,9 | 12,70 | 15,5 | 9,3 | 530 | 13 | 8 |
| 6.16 | 6 | 9 | 6,75 | 16,0 | 8,9 | 12,70 | 15,5 | 9,3 | 530 | 13 | 9 |
| 8 | 8 | 12 | 9,00 | 18,0 | 10,4 | 15,87 | 27,8 | 16,7 | 420 | 14 | 15 |
| 8.19 | 8 | 12 | 9,00 | 19,0 | 10,4 | 15,87 | 27,8 | 16,7 | 420 | 14 | 17 |
| 10 | 10 | 14 | 10,50 | 21,0 | 12,9 | 19,05 | 39,0 | 23,4 | 350 | 13 | 23 |
| 10.22 | 10 | 14 | 10,50 | 22,0 | 12,9 | 19,05 | 39,0 | 23,4 | 350 | 13 | 26 |
| 12 | 12 | 16 | 12,00 | 24,5 | 15,4 | 22,22 | 53,5 | 32,0 | 300 | 13 | 35 |
| 12.26 | 12 | 16 | 12,00 | 26,0 | 15,4 | 22,22 | 53,5 | 32,0 | 300 | 13 | 41 |
| 14 | 14 | 19 | 13,50 | 28,0 | 16,8 | 25,40 | 70,0 | 42,0 | 260 | 16 | 52 |
| 14.29 | 14 | 19 | 13,50 | 29,0 | 16,8 | 25,40 | 70,0 | 42,0 | 260 | 16 | 56 |
| 16 | 16 | 21 | 15,00 | 31,5 | 19,3 | 28,57 | 88,0 | 52,5 | 230 | 15 | 72 |
| 16.32 | 16 | 21 | 15,00 | 32,0 | 19,3 | 28,57 | 88,0 | 52,5 | 230 | 15 | 75 |
| 18 | 18 | 23 | 16,50 | 34,5 | 21,8 | 31,75 | 106,5 | 64,0 | 210 | 15 | 95 |
| 18.35 | 18 | 23 | 16,50 | 35,0 | 21,8 | 31,75 | 106,5 | 64,0 | 210 | 15 | 97 |
| 20 | 20 | 25 | 18,00 | 38,0 | 24,3 | 34,92 | 130,0 | 78,0 | 190 | 14 | 127 |
| 20.40 | 20 | 25 | 18,00 | 40,0 | 24,3 | 34,92 | 130,0 | 78,0 | 190 | 14 | 142 |
| 22 | 22 | 28 | 20,00 | 41,0 | 25,8 | 38,10 | 162,0 | 97,0 | 170 | 15 | 159 |
| 22.42 | 22 | 28 | 20,00 | 42,0 | 25,8 | 38,10 | 162,0 | 97,0 | 170 | 15 | 169 |
| 25 | 25 | 31 | 22,00 | 46,0 | 29,6 | 42,86 | 204,0 | 122,0 | 150 | 15 | 222 |
| 25.47 | 25 | 31 | 22,00 | 47,0 | 29,6 | 42,86 | 204,0 | 122,0 | 150 | 15 | 230 |
| 30 | 30 | 37 | 25,00 | 54,0 | 34,8 | 50,80 | 281,0 | 168,0 | 130 | 17 | 350 |
| 30.55 | 30 | 37 | 25,00 | 55,0 | 34,8 | 50,80 | 281,0 | 168,0 | 130 | 17 | 369 |
| 35 | 35 | 43 | 28,00 | 62,0 | 37,7 | 57,15 | 343,0 | 206,0 | 110 | 19 | 505 |
| 35.65 | 35 | 43 | 28,00 | 65,0 | 37,7 | 57,15 | 343,0 | 206,0 | 110 | 19 | 545 |
| 40 | 40 | 49 | 35,00 | 72,0 | 44,2 | 65,96 | 495,0 | 286,0 | 100 | 16 | 832 |
| 40.75 | 40 | 49 | 35,00 | 75,0 | 44,2 | 65,96 | 495,0 | 286,0 | 100 | 16 | 894 |
| 50 | 50 | 60 | 45,00 | 90,0 | 55,9 | 82,00 | 800,0 | 485,0 | 80 | 14 | 1640 |

only for short-term revolutions recommended

Materials:

Insert: Stainless steel to 1.4571 with PTFE liner bonded to the inner surface
Ball: Stainless steel to 1.4404 Aisi 316, ground, polished

This series is also available with threaded bolt (see page 53).

Spherical Plain Bearings Series E - Maintenance Free

Series GE...EC (-2RS)

Spherical Plain Bearing,
steel running on PTFE,
maintenance free

For use at high
unidirectional loads

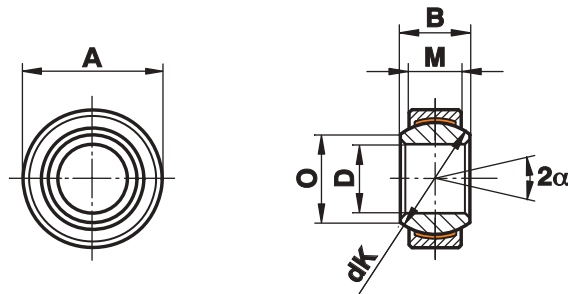

| Size (D) | B | M | A | O | dK | Static load C ₀ kN | Static load C ₀ kN -2RS | Dynamic load C kN | Dynamic load C kN -2RS | Maximum Pivoting Angle α (°) | Weight g |
|-------------------------------------|-----|-----|------------------------------------|-------|-------|-------------------------------|------------------------------------|-------------------|------------------------|------------------------------|----------|
| 4 ⁰ _{-0,008} | 5 | 3 | 12 ⁰ _{-0,008} | 6,0 | 8,0 | 5,4 | - | 2,1 | - | 16 | 3 |
| 5 ⁰ _{-0,008} | 6 | 4 | 14 ⁰ _{-0,008} | 8,0 | 10,0 | 9,1 | - | 3,6 | - | 13 | 4 |
| 6 ⁰ _{-0,008} | 6 | 4 | 14 ⁰ _{-0,008} | 8,0 | 10,0 | 9,1 | - | 3,6 | - | 13 | 4 |
| 8 ⁰ _{-0,008} | 8 | 5 | 16 ⁰ _{-0,008} | 10,2 | 13,0 | 14,0 | - | 5,8 | - | 15 | 7 |
| 10 ⁰ _{-0,008} | 9 | 6 | 19 ⁰ _{-0,009} | 13,2 | 16,0 | 21,0 | - | 8,6 | - | 12 | 11 |
| 12 ⁰ _{-0,008} | 10 | 7 | 22 ⁰ _{-0,009} | 14,9 | 18,0 | 28,0 | - | 11,0 | - | 11 | 17 |
| 15 ⁰ _{-0,008} | 12 | 9 | 26 ⁰ _{-0,009} | 18,4 | 22,0 | 45,0 | 59,0 | 18,0 | 17,5 | 8 | 26 |
| 16 ⁰ _{-0,008} | 14 | 10 | 30 ⁰ _{-0,009} | 20,7 | 25,0 | 56,0 | 56,0 | 22,0 | 22,5 | 10 | 40 |
| 17 ⁰ _{-0,008} | 14 | 10 | 30 ⁰ _{-0,009} | 20,7 | 25,0 | 56,0 | 75,0 | 22,0 | 22,5 | 10 | 40 |
| 20 ⁰ _{-0,010} | 16 | 12 | 35 ⁰ _{-0,011} | 24,1 | 29,0 | 78,0 | 104,0 | 31,0 | 31,5 | 9 | 64 |
| 25 ⁰ _{-0,010} | 20 | 16 | 42 ⁰ _{-0,011} | 29,3 | 35,5 | 127,0 | 204,0 | 51,0 | 51,0 | 7 | 115 |
| 30 ⁰ _{-0,010} | 22 | 18 | 47 ⁰ _{-0,011} | 34,2 | 40,7 | 166,0 | 263,0 | 65,0 | 66,0 | 6 | 149 |
| 35 ⁰ _{-0,012} | 25 | 20 | 55 ⁰ _{-0,013} | 39,7 | 47,0 | 211,0 | 338,0 | 84,0 | 140,0 | 6 | 228 |
| 40 ⁰ _{-0,012} | 28 | 22 | 62 ⁰ _{-0,013} | 45,0 | 53,0 | 262,0 | 419,0 | 104,0 | 185,0 | 7 | 318 |
| 45 ⁰ _{-0,012} | 32 | 25 | 68 ⁰ _{-0,013} | 50,7 | 60,0 | 337,0 | 540,0 | 135,0 | 240,0 | 7 | 421 |
| 50 ⁰ _{-0,012} | 35 | 28 | 75 ⁰ _{-0,013} | 55,9 | 66,0 | 415,0 | 665,0 | 166,0 | 295,0 | 6 | 562 |
| 55 ⁰ _{-0,015} | 40 | 32 | 85 ⁰ _{-0,015} | 62,3 | 74,0 | - | 852,0 | - | 355,0 | 7 | 864 |
| 60 ⁰ _{-0,015} | 44 | 36 | 90 ⁰ _{-0,015} | 66,8 | 80,0 | - | 1030,0 | - | 460,0 | 6 | 1030 |
| 70 ⁰ _{-0,015} | 49 | 40 | 105 ⁰ _{-0,015} | 77,8 | 92,0 | - | 1320,0 | - | 590,0 | 6 | 1570 |
| 80 ⁰ _{-0,015} | 55 | 45 | 120 ⁰ _{-0,015} | 89,4 | 105,0 | - | 1700,0 | - | 750,0 | 6 | 2320 |
| 90 ⁰ _{-0,020} | 60 | 50 | 130 ⁰ _{-0,018} | 98,1 | 115,0 | - | 2070,0 | - | 920,0 | 5 | 2790 |
| 100 ⁰ _{-0,020} | 70 | 55 | 150 ⁰ _{-0,018} | 109,5 | 130,0 | - | 2570,0 | - | 1145,0 | 7 | 4440 |
| 110 ⁰ _{-0,020} | 70 | 55 | 160 ⁰ _{-0,025} | 121,2 | 140,0 | - | 2770,0 | - | 1230,0 | 6 | 4830 |
| 120 ⁰ _{-0,020} | 85 | 70 | 180 ⁰ _{-0,025} | 135,5 | 160,0 | - | 4030,0 | - | 1790,0 | 6 | 8110 |
| 140 ¹⁾ _{-0,025} | 90 | 70 | 210 ⁰ _{-0,030} | 155,8 | 180,0 | - | 4530,0 | - | 2010,0 | 7 | 11200 |
| 160 ¹⁾ _{-0,025} | 105 | 80 | 230 ⁰ _{-0,030} | 170,2 | 200,0 | - | 5760,0 | - | 2560,0 | 8 | 14100 |
| 180 ¹⁾ _{-0,025} | 105 | 80 | 260 ⁰ _{-0,035} | 198,9 | 225,0 | - | 6480,0 | - | 2880,0 | 6 | 18500 |
| 200 ¹⁾ _{-0,030} | 130 | 100 | 290 ⁰ _{-0,035} | 213,5 | 250,0 | - | 9000,0 | - | 4000,0 | 7 | 28400 |
| 220 ¹⁾ _{-0,030} | 135 | 100 | 320 ⁰ _{-0,040} | 239,5 | 275,0 | - | 9900,0 | - | 4400,0 | 8 | 35700 |
| 240 ¹⁾ _{-0,030} | 140 | 100 | 340 ⁰ _{-0,040} | 265,3 | 300,0 | - | 10800,0 | - | 4800,0 | 8 | 39700 |
| 260 ¹⁾ _{-0,035} | 150 | 110 | 370 ⁰ _{-0,040} | 288,3 | 325,0 | - | 12870,0 | - | 5700,0 | 7 | 51500 |
| 280 ¹⁾ _{-0,035} | 155 | 120 | 400 ⁰ _{-0,040} | 313,8 | 350,0 | - | 15120,0 | - | 6700,0 | 6 | 64900 |
| 300 ¹⁾ _{-0,035} | 165 | 120 | 430 ⁰ _{-0,045} | 336,7 | 375,0 | - | 16200,0 | - | 7200,0 | 7 | 77600 |

Materials:

Insert: Bearing steel to 100Cr6, Aisi 52100, with PTFE liner, bonded to the inner surface
from size 15 available sealed from both sides (-2RS)

from size 35 only sealed from both sides (-2RS)

from size 4 to 50 when without seal, bearing steel C45/Aisi 1045 with PTFE liner, bonded to the inner surface

Ball: Bearing steel to 100Cr6, Aisi 52100, hardened, ground, polished, hard chrome plated on the running surface

¹⁾ from size 140 the hardened inserts are two pieced and secured with tension spring

FLURO®-Gelenklager GmbH

Spherical Plain Bearings Series E - Stainless, Maintenance Free

Series

GE...EC-NIRO (-2RSF)

Spherical Plain Bearing
Series E, Maintenance
Free

For use at high
unidirectional loads in
corrosive environments

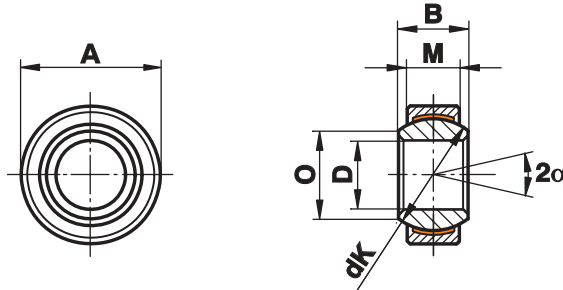

| Size (D) | B | M | A | O | dK | Static load C ₀ kN | Static load C ₀ kN -2RS | Dynamic load C kN | Dynamic load C kN -2RS | Maximum Pivoting Angle α (°) | Weight g |
|------------------------------------|----|----|------------------------------------|-------|-------|-------------------------------|------------------------------------|-------------------|------------------------|------------------------------|----------|
| 6 ⁰ _{-0,008} | 6 | 4 | 14 ⁰ _{-0,008} | 8,0 | 10,0 | 9,0 | - | 4 | - | 13 | 4 |
| 8 ⁰ _{-0,008} | 8 | 5 | 16 ⁰ _{-0,008} | 10,2 | 13,0 | 15,6 | - | 7 | - | 15 | 7 |
| 10 ⁰ _{-0,008} | 9 | 6 | 19 ⁰ _{-0,009} | 13,2 | 16,0 | 23,4 | - | 10 | - | 12 | 11 |
| 12 ⁰ _{-0,008} | 10 | 7 | 22 ⁰ _{-0,009} | 14,9 | 18,0 | 32,0 | - | 14 | - | 11 | 16 |
| 15 ⁰ _{-0,008} | 12 | 9 | 26 ⁰ _{-0,009} | 18,4 | 22,0 | 50,0 | - | 30 | - | 8 | 26 |
| 16 ⁰ _{-0,008} | 14 | 10 | 30 ⁰ _{-0,009} | 20,7 | 25,0 | 65,0 | - | 39 | - | 10 | 49 |
| 17 ⁰ _{-0,008} | 14 | 10 | 30 ⁰ _{-0,009} | 20,7 | 25,0 | 65,0 | - | 39 | - | 10 | 38 |
| 20 ⁰ _{-0,010} | 16 | 12 | 35 ⁰ _{-0,011} | 24,2 | 29,0 | 90,5 | - | 54 | - | 9 | 61 |
| 25 ⁰ _{-0,010} | 20 | 16 | 42 ⁰ _{-0,011} | 29,3 | 35,5 | 159,0 | 137 | 96 | 78 | 7 | 110 |
| 30 ⁰ _{-0,010} | 22 | 18 | 47 ⁰ _{-0,011} | 34,2 | 40,7 | 197,0 | 155 | 118 | 89 | 6 | 140 |
| 35 ⁰ _{-0,012} | 25 | 20 | 55 ⁰ _{-0,013} | 39,8 | 47,0 | 298,0 | 217 | 153 | 124 | 6 | 220 |
| 40 ⁰ _{-0,012} | 28 | 22 | 62 ⁰ _{-0,013} | 45,0 | 53,0 | 370,6 | 276 | 190 | 158 | 7 | 300 |
| 45 ⁰ _{-0,012} | 32 | 25 | 68 ⁰ _{-0,013} | 50,8 | 60,0 | 481,0 | 353 | 247 | 202 | 7 | 400 |
| 50 ⁰ _{-0,012} | 35 | 28 | 75 ⁰ _{-0,013} | 56,0 | 66,0 | 598,0 | 457 | 308 | 261 | 6 | 540 |
| 60 ⁰ _{-0,015} | 44 | 36 | 90 ⁰ _{-0,015} | 66,8 | 80,0 | 935,0 | 722 | 481 | 413 | 6 | 1000 |
| 70 ⁰ _{-0,015} | 49 | 40 | 105 ⁰ _{-0,015} | 77,9 | 92,0 | 1204,0 | 976 | 619 | 558 | 6 | 1500 |
| 80 ⁰ _{-0,015} | 55 | 45 | 120 ⁰ _{-0,015} | 89,4 | 105,0 | 1540,0 | 1246 | 792 | 712 | 6 | 2200 |
| 90 ⁰ _{-0,020} | 60 | 50 | 130 ⁰ _{-0,018} | 98,1 | 115,0 | 1892,0 | 1525 | 1080 | 872 | 5 | 2700 |
| 100 ⁰ _{-0,020} | 70 | 55 | 150 ⁰ _{-0,018} | 109,5 | 130,0 | 2366,0 | 1997 | 1350 | 1141 | 7 | 4400 |
| 110 ⁰ _{-0,020} | 70 | 55 | 160 ⁰ _{-0,025} | 121,2 | 140,0 | 2548,0 | 2151 | 1460 | 1229 | 6 | 4700 |
| 120 ⁰ _{-0,020} | 85 | 70 | 180 ⁰ _{-0,025} | 135,5 | 160,0 | 3752,0 | 3186 | 2140 | 1821 | 6 | 8000 |

Materials:

Insert: Stainless steel to 1.4571, Aiso 316Ti, with PTFE liner bonded to the inner surface from size 0 with high performance PTFE compound from size 25 available sealed from both sides (-2RSF)

Ball: Stainless steel to 1.4125, Aisi 440C / 1.4112, Aisi 440B, hardened, ground, polished

Sealing: H Ecopur

Rod Ends Series E - Steel on Steel

Series EI (-2RS)

Rod Ends with female thread made from free-cutting or heat-treated steel, zinc plated, with steel on steel Spherical Plain Bearings which require lubrication

For use at high multi-directional loads and limited fitting dimensions

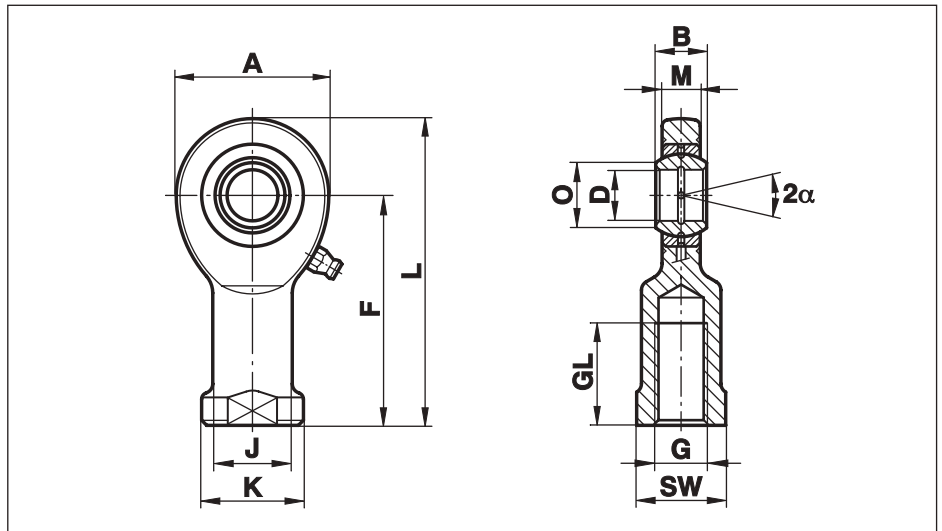

| Size (D) | B | M | A | F | L | K | J | O | SW | G | GL | Static load C ₀ kN | Dynamic load C kN | Maximum Pivoting Angle α (°) | Weight g |
|----------|----|------|-----|-----|-------|-----|------|------|-----|----------|----|-------------------------------|-------------------|------------------------------|----------|
| 6 | 6 | 4,4 | 21 | 30 | 40,0 | 13 | 10,0 | 8,0 | 11 | M 6 | 12 | 10,3 | 3,4 | 13 | 21 |
| 8 | 8 | 6,0 | 24 | 36 | 48,0 | 16 | 12,5 | 10,2 | 14 | M 8 | 16 | 15,8 | 5,5 | 15 | 38 |
| 10 | 9 | 7,0 | 29 | 43 | 57,0 | 19 | 15,0 | 13,2 | 17 | M 10 | 20 | 23,4 | 8,1 | 12 | 60 |
| 12 | 10 | 8,0 | 34 | 50 | 67,0 | 22 | 17,5 | 14,9 | 19 | M 12 | 23 | 31,0 | 10,8 | 11 | 96 |
| 15 | 12 | 10,0 | 40 | 61 | 81,0 | 26 | 21,0 | 18,4 | 22 | M 14 | 29 | 42,5 | 17,0 | 8 | 180 |
| 16 | 14 | 11,0 | 46 | 67 | 90,0 | 30 | 24,0 | 20,7 | 27 | M 16 | 33 | 54,5 | 21,2 | 10 | 220 |
| 17 | 14 | 11,0 | 46 | 67 | 90,0 | 30 | 24,0 | 20,7 | 27 | M 16 | 33 | 54,5 | 21,2 | 10 | 220 |
| 20 | 16 | 13,0 | 53 | 77 | 103,5 | 35 | 27,5 | 24,2 | 32 | M 20x1,5 | 40 | 62,5 | 30,0 | 9 | 350 |
| 25 | 20 | 17,0 | 64 | 94 | 126,0 | 42 | 33,5 | 29,3 | 36 | M 24x2 | 48 | 92,0 | 48,0 | 7 | 640 |
| 30 | 22 | 19,0 | 73 | 110 | 146,5 | 50 | 40,0 | 34,2 | 41 | M 30x2 | 56 | 124,0 | 62,0 | 6 | 930 |
| 35 | 25 | 21,0 | 82 | 125 | 166,0 | 58 | 47,0 | 39,8 | 50 | M 36x3 | 60 | 144,0 | 80,0 | 6 | 1300 |
| 40 | 28 | 23,0 | 92 | 142 | 188,0 | 65 | 52,0 | 45,0 | 55 | M 39x3 | 65 | 178,0 | 100,0 | 7 | 2000 |
| 40 | 28 | 23,0 | 92 | 142 | 188,0 | 65 | 52,0 | 45,0 | 55 | M 42x3 | 65 | 102,5 | 99,0 | 7 | 2060 |
| 45 | 32 | 27,0 | 102 | 145 | 196,0 | 70 | 58,0 | 50,8 | 60 | M 42x3 | 65 | 240,0 | 127,0 | 7 | 2500 |
| 45 | 32 | 27,0 | 102 | 145 | 196,0 | 70 | 58,0 | 50,8 | 60 | M 45x3 | 65 | 141,0 | 127,0 | 7 | 2640 |
| 50 | 35 | 30,0 | 112 | 160 | 216,0 | 75 | 62,0 | 56,0 | 65 | M 45x3 | 68 | 290,0 | 156,0 | 6 | 3500 |
| 50 | 35 | 30,0 | 112 | 160 | 216,0 | 75 | 62,0 | 56,0 | 65 | M 52x3 | 68 | 140,0 | 156,0 | 6 | 3400 |
| 60 | 44 | 38,0 | 135 | 175 | 242,5 | 88 | 70,0 | 66,8 | 75 | M 52x3 | 70 | 450,0 | 245,0 | 6 | 5550 |
| 60 | 44 | 38,0 | 135 | 175 | 242,5 | 88 | 70,0 | 66,8 | 75 | M 60x4 | 70 | 183,0 | 245,0 | 6 | 5430 |
| 70 | 49 | 42,0 | 160 | 200 | 280,0 | 98 | 80,0 | 77,9 | 85 | M 56x4 | 80 | 610,0 | 315,0 | 6 | 8600 |
| 70 | 49 | 42,0 | 160 | 200 | 280,0 | 98 | 80,0 | 77,9 | 85 | M 72x4 | 80 | 306,0 | 313,0 | 6 | 8120 |
| 80 | 55 | 47,0 | 180 | 230 | 320,0 | 110 | 95,0 | 89,4 | 100 | M 64x4 | 85 | 695,0 | 400,0 | 6 | 12000 |
| 80 | 55 | 47,0 | 180 | 230 | 320,0 | 110 | 95,0 | 89,4 | 100 | M 80x4 | 85 | 387,0 | 400,0 | 6 | 12800 |

Materials:

Housing: up to size 10 turned, from free-cutting steel to 9SMnPb28K, 12L13, galvanised
from size 12 forged from heat-treated steel to C45, Aisi 1045, galvanised

Bearing: Steel on steel bearing GE...E, requiring lubrication (see page 78)
from size 15 available sealed from both sides (-2RS)
from size 60 only available sealed from both sides (-2RS)

Greasing: up to size 17 without lubrication fitting
from size 20 fitted with hydraulic grease nipples to DIN 71412

Rod Ends Series E - Steel on Steel

Series EA (-2RS)

Rod Ends with male thread made from free-cutting or heat-treated steel, zinc plated, with steel on steel Spherical Plain Bearings which require lubrication

For use at high multi-directional loads and limited fitting dimensions

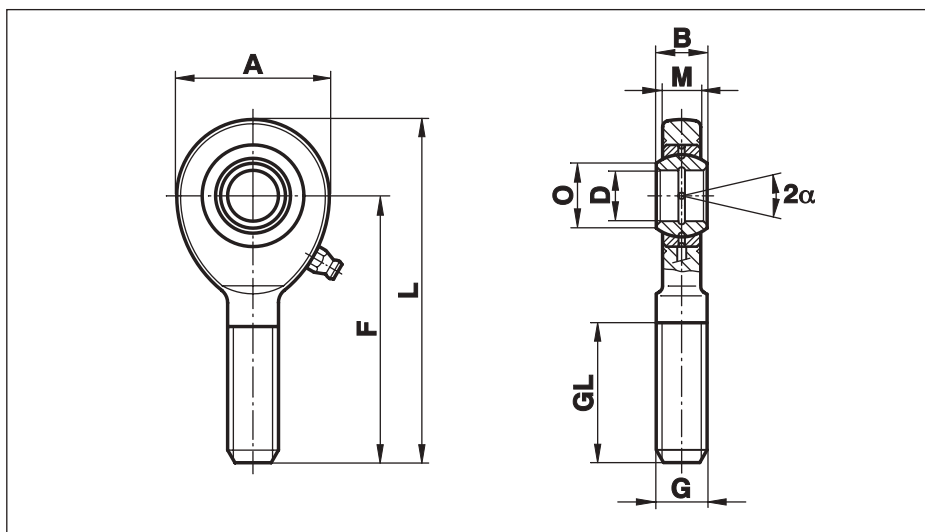

| Size (D) | B | M | A | F | L | O | G | GL | Static load C ₀ kN | Dynamic load C kN | Maximum Pivoting Angle α (°) | Weight g |
|----------|----|------|-----|-----|-------|------|----------|-----|-------------------------------|-------------------|------------------------------|----------|
| 6 | 6 | 4,4 | 21 | 36 | 46,0 | 8,0 | M 6 | 18 | 6,9 | 3,4 | 13 | 16 |
| 8 | 8 | 6,0 | 24 | 42 | 54,0 | 10,2 | M 8 | 22 | 12,7 | 5,5 | 15 | 28 |
| 10 | 9 | 7,0 | 29 | 48 | 62,0 | 13,2 | M 10 | 26 | 19,9 | 8,1 | 12 | 50 |
| 12 | 10 | 8,0 | 34 | 54 | 71,0 | 14,9 | M 12 | 28 | 29,0 | 10,8 | 11 | 86 |
| 15 | 12 | 10,0 | 40 | 63 | 83,0 | 18,4 | M 14 | 34 | 39,5 | 17,0 | 8 | 140 |
| 16 | 14 | 11,0 | 46 | 69 | 92,0 | 20,7 | M 16 | 36 | 54,0 | 21,2 | 10 | 190 |
| 17 | 14 | 11,0 | 46 | 69 | 92,0 | 20,7 | M 16 | 36 | 54,0 | 21,2 | 10 | 190 |
| 20 | 16 | 13,0 | 53 | 78 | 104,5 | 24,2 | M 20x1,5 | 43 | 62,5 | 30,0 | 9 | 320 |
| 25 | 20 | 17,0 | 64 | 94 | 126,0 | 29,3 | M 24x2 | 53 | 92,0 | 48,0 | 7 | 560 |
| 30 | 22 | 19,0 | 73 | 110 | 146,5 | 34,2 | M 30x2 | 65 | 124,0 | 62,0 | 6 | 890 |
| 35 | 25 | 21,0 | 82 | 140 | 181,0 | 39,8 | M 36x3 | 82 | 144,0 | 80,0 | 6 | 1400 |
| 40 | 28 | 23,0 | 92 | 150 | 196,0 | 45,0 | M 39x3 | 86 | 178,0 | 100,0 | 7 | 1800 |
| 40 | 28 | 23,0 | 92 | 150 | 196,0 | 45,0 | M 42x3 | 86 | 180,0 | 99,0 | 7 | 1850 |
| 45 | 32 | 27,0 | 102 | 163 | 214,0 | 50,8 | M 42x3 | 94 | 259,0 | 127,0 | 7 | 2610 |
| 45 | 32 | 27,0 | 102 | 163 | 214,0 | 50,8 | M 45x3 | 94 | 240,0 | 127,0 | 7 | 2550 |
| 50 | 35 | 30,0 | 112 | 185 | 241,0 | 56,0 | M 45x3 | 107 | 313,0 | 156,0 | 6 | 3450 |
| 50 | 35 | 30,0 | 112 | 185 | 241,0 | 56,0 | M 52x3 | 107 | 290,0 | 156,0 | 6 | 3650 |
| 60 | 44 | 38,0 | 135 | 210 | 277,5 | 66,8 | M 52x3 | 115 | 485,0 | 245,0 | 6 | 5900 |
| 60 | 44 | 38,0 | 135 | 210 | 277,5 | 66,8 | M 60x4 | 115 | 450,0 | 245,0 | 6 | 5820 |
| 70 | 49 | 42,0 | 160 | 235 | 315,0 | 77,9 | M 56x4 | 125 | 564,0 | 315,0 | 6 | 8200 |
| 70 | 49 | 42,0 | 160 | 235 | 315,0 | 77,9 | M 72x4 | 125 | 610,0 | 313,0 | 6 | 8080 |
| 80 | 55 | 47,0 | 180 | 270 | 360,0 | 89,4 | M 64x4 | 140 | 689,0 | 400,0 | 6 | 12000 |
| 80 | 55 | 47,0 | 180 | 270 | 360,0 | 89,4 | M 80x4 | 140 | 750,0 | 400,0 | 6 | 12000 |

Materials:

Housing: up to size 10 turned, from free-cutting steel to 9SMnPb28K, 12L13, galvanised
from size 12 forged from heat-treated steel to C45, Aisi 1045, galvanised

Bearing: Steel on steel bearing GE...E, requiring lubrication (see page 78)
from size 15 available sealed from both sides (-2RS)
from size 60 only available sealed from both sides (-2RS)

Greasing: up to size 17 without lubrication fitting
from size 20 fitted with hydraulic grease nipples to DIN 71412

Rod Ends Series E - Maintenance Free

Series EI..D (-2RS)

Rod End Series E with female thread, and maintenance free Spherical Plain Bearing

For use at high uni-directional loads and limited fitting dimensions

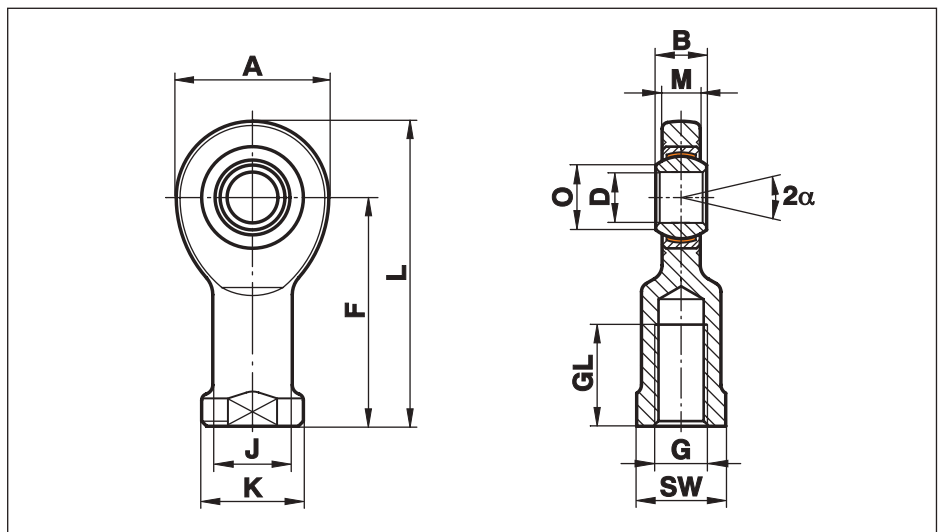

| Size (D) | B | M | A | F | L | K | J | O | SW | G | GL | Static load C ₀ kN | Static load C ₀ kN -2RS | Dynamic load C kN | Dynamic load C kN -2RS | Maximum Pivoting Angle α (°) | Weight g |
|----------|----|------|-----|-----|-------|-----|------|------|-----|----------|----|-------------------------------|------------------------------------|-------------------|------------------------|------------------------------|----------|
| 6 | 6 | 4,4 | 21 | 30 | 40,0 | 13 | 10,0 | 8,0 | 11 | M 6 | 12 | 10,3 | - | 3,6 | - | 13 | 21 |
| 8 | 8 | 6,0 | 24 | 36 | 48,0 | 16 | 12,5 | 10,2 | 14 | M 8 | 16 | 15,8 | - | 5,8 | - | 15 | 38 |
| 10 | 9 | 7,0 | 29 | 43 | 57,0 | 19 | 15,0 | 13,2 | 17 | M 10 | 20 | 23,4 | - | 8,6 | - | 12 | 60 |
| 12 | 10 | 8,0 | 34 | 50 | 67,0 | 22 | 17,5 | 14,9 | 19 | M 12 | 23 | 31,0 | - | 11,5 | - | 11 | 96 |
| 15 | 12 | 10,0 | 40 | 61 | 81,0 | 26 | 21,0 | 18,4 | 22 | M 14 | 29 | 42,5 | 42,5 | 17,5 | 25 | 8 | 180 |
| 16 | 14 | 11,0 | 46 | 67 | 90,0 | 30 | 24,0 | 20,7 | 27 | M 16 | 33 | 54,5 | 54,5 | 22,5 | 32 | 10 | 220 |
| 17 | 14 | 11,0 | 46 | 67 | 90,0 | 30 | 24,0 | 20,7 | 27 | M 16 | 33 | 54,5 | 54,5 | 22,5 | 32 | 10 | 220 |
| 20 | 16 | 13,0 | 53 | 77 | 103,5 | 35 | 27,5 | 24,2 | 32 | M 20x1,5 | 40 | 62,5 | 62,5 | 31,5 | 45 | 9 | 350 |
| 25 | 20 | 17,0 | 64 | 94 | 126,0 | 42 | 33,5 | 29,3 | 36 | M 24x2 | 48 | 92,0 | 92,0 | 51,0 | 85 | 7 | 640 |
| 30 | 22 | 19,0 | 73 | 110 | 146,5 | 50 | 40,0 | 34,2 | 41 | M 30x2 | 56 | 124,0 | 124,0 | 66,0 | 110 | 6 | 930 |
| 35 | 25 | 21,0 | 82 | 125 | 166,0 | 58 | 47,0 | 39,8 | 50 | M 36x3 | 60 | 144,0 | 144,0 | 140,0 | 140 | 6 | 1300 |
| 40 | 28 | 23,0 | 92 | 142 | 188,0 | 65 | 52,0 | 45,0 | 55 | M 39x3 | 65 | 178,0 | 180,0 | 185,0 | 175 | 7 | 2000 |
| 40 | 28 | 23,0 | 92 | 142 | 188,0 | 65 | 52,0 | 45,0 | 55 | M 42x3 | 65 | 102,5 | 102,5 | 104,0 | 175 | 7 | 2060 |
| 45 | 32 | 27,0 | 102 | 145 | 196,0 | 70 | 58,0 | 50,8 | 60 | M 42x3 | 65 | 240,0 | 240,0 | 240,0 | 225 | 7 | 2500 |
| 45 | 32 | 27,0 | 102 | 145 | 196,0 | 70 | 58,0 | 50,8 | 60 | M 45x3 | 65 | 141,0 | 141,0 | 135,0 | 225 | 7 | 2640 |
| 50 | 35 | 30,0 | 112 | 160 | 216,0 | 75 | 62,0 | 56,0 | 65 | M 45x3 | 68 | 290,0 | 290,0 | 295,0 | 275 | 6 | 3500 |
| 50 | 35 | 30,0 | 112 | 160 | 216,0 | 75 | 62,0 | 56,0 | 65 | M 52x3 | 68 | 140,0 | 140,0 | 166,0 | 275 | 6 | 3400 |
| 60 | 44 | 38,0 | 135 | 175 | 242,5 | 88 | 70,0 | 66,8 | 75 | M 52x3 | 70 | 450,0 | 450,0 | 460,0 | 430 | 6 | 5550 |
| 60 | 44 | 38,0 | 135 | 175 | 242,5 | 88 | 70,0 | 66,8 | 75 | M 60x3 | 70 | - | 183,0 | - | 430 | 6 | 5430 |
| 70 | 49 | 42,0 | 160 | 200 | 280,0 | 98 | 80,0 | 77,9 | 85 | M 56x4 | 80 | 610,0 | 610,0 | 590,0 | 550 | 6 | 8600 |
| 70 | 49 | 42,0 | 160 | 200 | 280,0 | 98 | 80,0 | 77,9 | 85 | M 72x4 | 80 | - | 306,0 | - | 550 | 6 | 8120 |
| 80 | 55 | 47,0 | 180 | 230 | 320,0 | 110 | 95,0 | 89,4 | 100 | M 64x4 | 85 | 695,0 | 750,0 | 750,0 | 705 | 6 | 12000 |
| 80 | 55 | 47,0 | 180 | 230 | 320,0 | 110 | 95,0 | 89,4 | 100 | M 80x4 | 85 | - | 387,0 | - | 705 | 6 | 11800 |

Materials:

Housing: up to size 10 turned, from free-cutting steel to 9SMnPb28K, 12L13, galvanised
from size 12 forged from heat-treated steel to C45, Aisi 1045, galvanised

Bearing: maintenance free steel/PTFE bearing GE...EC (see page 70)
from size 15 available sealed from both sides (-2RS)
from size 60 only available sealed from both sides (-2RS)

⚠ Please note: The dynamic load "C" of the bearing of some rod ends is in some sizes higher than the static load "C₀" of the rod end.

Rod Ends Series E - Maintenance Free

Series EA..D (-2RS)

Rod End Series E with male thread, and maintenance free Spherical Plain Bearing

For use at high uni-directional loads and limited fitting dimensions

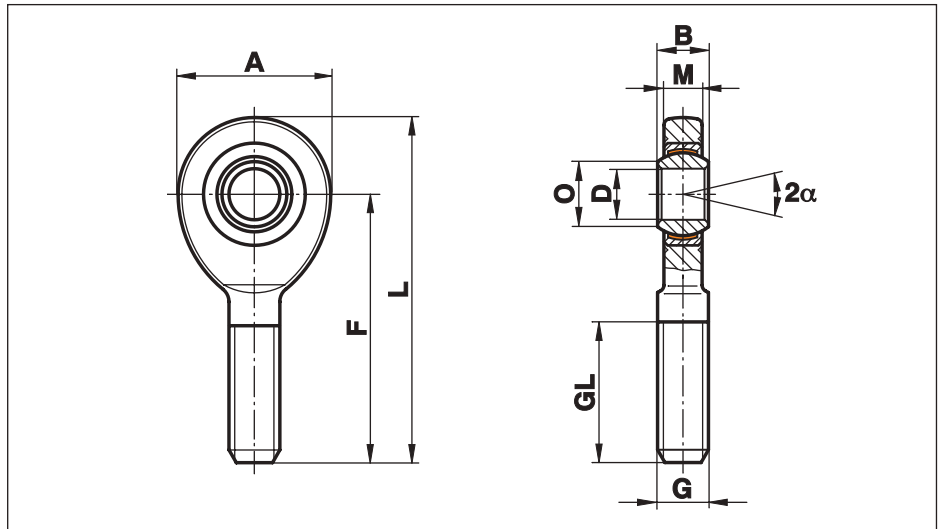

| Size (D) | B | M | A | F | L | O | G | GL | Static load C ₀ kN | Static load C ₀ kN -2RS | Dynamic load C kN | Dynamic load C kN -2RS | Maximum Pivoting Angle α (°) | Weight g |
|----------|----|------|-----|-----|-------|------|----------|-----|-------------------------------|------------------------------------|-------------------|------------------------|------------------------------|----------|
| 6 | 6 | 4,4 | 21 | 36 | 46,0 | 8,0 | M 6 | 18 | 6,9 | - | 3,6 | - | 13 | 16 |
| 8 | 8 | 6,0 | 24 | 42 | 54,0 | 10,2 | M 8 | 22 | 12,7 | - | 5,8 | - | 15 | 28 |
| 10 | 9 | 7,0 | 29 | 48 | 62,0 | 13,2 | M 10 | 26 | 19,9 | - | 8,6 | - | 12 | 50 |
| 12 | 10 | 8,0 | 34 | 54 | 71,0 | 14,9 | M 12 | 28 | 29,0 | - | 11,5 | - | 11 | 86 |
| 15 | 12 | 10,0 | 40 | 63 | 83,0 | 18,4 | M 14 | 34 | 39,5 | 39,5 | 17,5 | 25 | 8 | 140 |
| 16 | 14 | 11,0 | 46 | 69 | 92,0 | 20,7 | M 16 | 36 | 54,0 | 54,0 | 22,5 | 32 | 10 | 190 |
| 17 | 14 | 11,0 | 46 | 69 | 92,0 | 20,7 | M 16 | 36 | 54,0 | 54,0 | 22,5 | 32 | 10 | 190 |
| 20 | 16 | 13,0 | 53 | 78 | 104,5 | 24,2 | M 20x1,5 | 43 | 62,5 | 62,5 | 31,5 | 45 | 9 | 320 |
| 25 | 20 | 17,0 | 64 | 94 | 126,0 | 29,3 | M 24x2 | 53 | 92,0 | 92,0 | 51,0 | 85 | 7 | 560 |
| 30 | 22 | 19,0 | 73 | 110 | 146,5 | 34,2 | M 30x2 | 65 | 124,0 | 124,0 | 66,0 | 110 | 6 | 890 |
| 35 | 25 | 21,0 | 82 | 140 | 181,0 | 39,8 | M 36x3 | 82 | 144,0 | 144,0 | 140,0 | 140 | 6 | 1400 |
| 40 | 28 | 23,0 | 92 | 150 | 196,0 | 45,0 | M 39x3 | 86 | 178,0 | 178,0 | 185,0 | 175 | 7 | 1800 |
| 40 | 28 | 23,0 | 92 | 150 | 196,0 | 45,0 | M 42x3 | 86 | 180,0 | 178,0 | 104,0 | 175 | 7 | 1850 |
| 45 | 32 | 27,0 | 102 | 163 | 214,0 | 50,8 | M 42x3 | 94 | 240,0 | 240,0 | 240,0 | 225 | 7 | 2610 |
| 45 | 32 | 27,0 | 102 | 163 | 214,0 | 50,8 | M 45x3 | 94 | 240,0 | 240,0 | 135,0 | 225 | 7 | 2550 |
| 50 | 35 | 30,0 | 112 | 185 | 241,0 | 56,0 | M 45x3 | 107 | 290,0 | 290,0 | 295,0 | 275 | 6 | 3450 |
| 50 | 35 | 30,0 | 112 | 185 | 241,0 | 56,0 | M 52x3 | 107 | 290,0 | 290,0 | 166,0 | 275 | 6 | 3650 |
| 60 | 44 | 38,0 | 135 | 210 | 277,5 | 66,8 | M 52x3 | 115 | 450,0 | 450,0 | 460,0 | 430 | 6 | 5900 |
| 60 | 44 | 38,0 | 135 | 210 | 277,5 | 66,8 | M 60x4 | 115 | - | 450,0 | - | 430 | 6 | 5820 |
| 70 | 49 | 42,0 | 160 | 235 | 315,0 | 77,9 | M 56x4 | 125 | 610,0 | 610,0 | 590,0 | 550 | 6 | 8200 |
| 70 | 49 | 42,0 | 160 | 235 | 315,0 | 77,9 | M 72x4 | 125 | - | 610,0 | - | 550 | 6 | 8080 |
| 80 | 55 | 47,0 | 180 | 270 | 360,0 | 89,4 | M 64x4 | 140 | 750,0 | 750,0 | 750,0 | 705 | 6 | 12000 |
| 80 | 55 | 47,0 | 180 | 270 | 360,0 | 89,4 | M 80x4 | 140 | - | 750,0 | - | 705 | 6 | 12000 |

Materials:

Housing: up to size 10 turned, from free-cutting steel to 9SMnPb28K, 12L13, galvanised
from size 12 forged from heat-treated steel to C45, Aisi 1045, galvanised

Bearing: maintenance free steel/PTFE bearing GE...EC (see page 70)
from size 15 available sealed from both sides (-2RS)
from size 60 only available sealed from both sides (-2RS)

⚠ Please note: The dynamic load "C" of the bearing of some rod ends is in some sizes higher than the static load "C₀" of the rod end.

Rod Ends Series E - Stainless, Maintenance Free

Series

EL..D-NIRO (-2RSF)

Rod End Series E
with female thread,
maintenance free
Spherical Plain Bearing
GE..EC-NIRO (-2RSF)

For use at high unidirectional loads, in corrosive environments and limited fitting dimensions

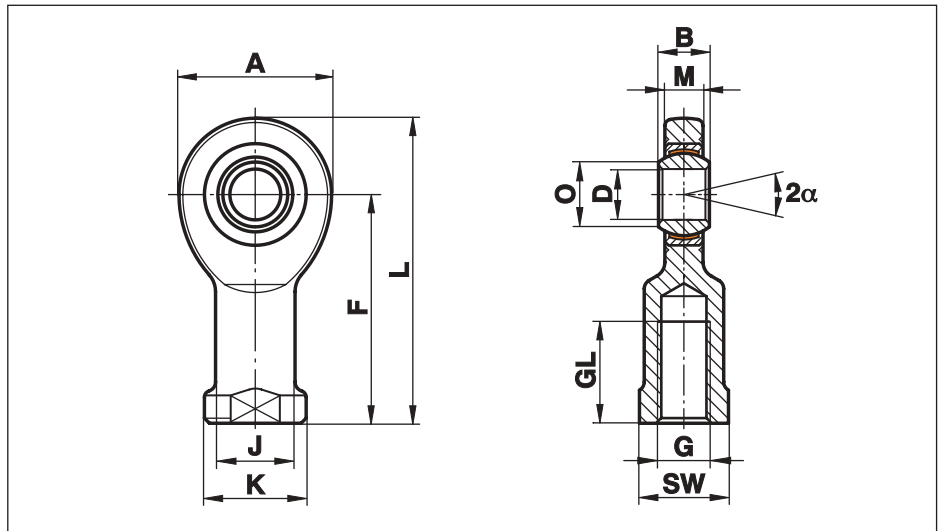

| Size (D) | B | M | A | F | L | K | J | O | SW | G | GL | Static load C ₀ kN | Static load C ₀ kN -2RS | Dynamic load C kN | Dynamic load C kN -2RS | Maximum Pivoting Angle α (°) | Weight g |
|------------------|----|------|-----|-----|-------|-----|------|------|-----|----------|----|-------------------------------|------------------------------------|-------------------|------------------------|------------------------------|----------|
| 6 | 6 | 4,4 | 21 | 30 | 40,0 | 13 | 10,0 | 8,0 | 11 | M 6 | 12 | 6,0 | - | 4 | - | 13 | 21 |
| 8 | 8 | 6,0 | 24 | 36 | 48,0 | 16 | 12,5 | 10,2 | 14 | M 8 | 16 | 9,2 | - | 7 | - | 15 | 38 |
| 10 | 9 | 7,0 | 29 | 43 | 57,0 | 19 | 15,0 | 13,2 | 17 | M 10 | 20 | 13,6 | - | 10 | - | 12 | 60 |
| 12 | 10 | 8,0 | 34 | 50 | 67,0 | 22 | 17,5 | 14,9 | 19 | M 12 | 23 | 18,0 | - | 14 | - | 11 | 96 |
| 15 | 12 | 10,0 | 40 | 61 | 81,0 | 26 | 21,0 | 18,4 | 22 | M 14 | 29 | 26,5 | - | 30 | - | 8 | 180 |
| 16 | 14 | 11,0 | 46 | 67 | 90,0 | 30 | 24,0 | 20,7 | 27 | M 16 | 33 | 34,0 | - | 39 | - | 10 | 220 |
| 17 | 14 | 11,0 | 46 | 67 | 90,0 | 30 | 24,0 | 20,7 | 27 | M 16 | 33 | 34,0 | - | 39 | - | 10 | 220 |
| 20 | 16 | 13,0 | 53 | 77 | 103,5 | 35 | 27,5 | 24,2 | 32 | M 20x1,5 | 40 | 45,0 | - | 54 | - | 9 | 350 |
| 25 | 20 | 17,0 | 64 | 94 | 126,0 | 42 | 33,5 | 29,3 | 36 | M 24x2 | 48 | 73,0 | 73 | 96 | 78 | 7 | 640 |
| 30 | 22 | 19,0 | 73 | 110 | 146,5 | 50 | 40,0 | 34,2 | 41 | M 30x2 | 56 | 97,0 | 97 | 118 | 89 | 6 | 930 |
| 35 | 25 | 21,0 | 82 | 125 | 166,0 | 58 | 47,0 | 39,8 | 50 | M 36x3 | 60 | 111,0 | 111 | 153 | 124 | 6 | 1300 |
| 40 | 28 | 23,0 | 92 | 142 | 188,0 | 65 | 52,0 | 45,0 | 55 | M 39x3 | 65 | 135,0 | 135 | 190 | 158 | 7 | 2000 |
| 45 ¹⁾ | 32 | 27,0 | 102 | 145 | 196,0 | 70 | 58,0 | 50,8 | 60 | M 42x3 | 65 | 178,0 | 178 | 247 | 202 | 7 | 2500 |
| 50 | 35 | 30,0 | 112 | 160 | 216,0 | 75 | 62,0 | 56,0 | 65 | M 45x3 | 68 | 216,0 | 216 | 308 | 261 | 6 | 3500 |
| 60 ¹⁾ | 44 | 38,0 | 135 | 175 | 242,5 | 88 | 70,0 | 66,8 | 75 | M 52x3 | 70 | 336,0 | 336 | 481 | 413 | 6 | 5550 |
| 70 ¹⁾ | 49 | 42,0 | 160 | 200 | 280,0 | 98 | 80,0 | 77,9 | 85 | M 56x4 | 80 | 459,0 | 459 | 619 | 558 | 6 | 8600 |
| 80 ¹⁾ | 55 | 47,0 | 180 | 230 | 320,0 | 110 | 95,0 | 89,4 | 100 | M 64x4 | 85 | 570,0 | 570 | 792 | 712 | 6 | 12000 |

Materials:

Housing: from size 6 to 40 stainless steel to 1.4301, Aisi 304, forged, polished
from size 45 stainless steel to 1.4301, Aisi 304, turned
from size 50 stainless steel to 1.4571, Aisi 316Ti, turned

Bearing: maintenance free stainless steel Spherical Plain Bearing GE...EC-NIRO (-2RSF) (see page 71)
from size 25 available sealed from both sides (-2RS)

¹⁾ availability and price on request

⚠ Please note: The dynamic load "C" of the bearing of some rod ends is in some sizes higher than the static load "C₀" of the rod end.

Rod Ends Series E - Stainless, Maintenance Free

Series

EA..D-NIRO (-2RSF)

Rod End with male thread, maintenance free, made from stainless steel with maintenance free Spherical Plain Bearings GE..EC-NIRO

For use at high unidirectional loads, in corrosive environments and limited fitting dimensions

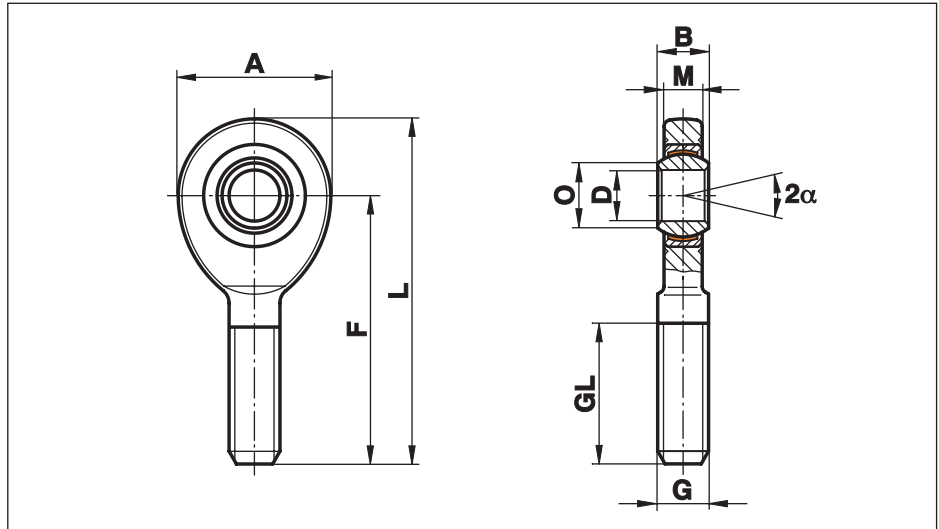

| Size (D) | B | M | A | F | L | O | G | GL | Static load C ₀ kN | Static load C ₀ kN -2RS | Dynamic load C kN | Dynamic load C kN -2RS | Maximum Pivoting Angle α (°) | Weight g |
|------------------|----|------|-----|-----|-------|------|----------|-----|-------------------------------|------------------------------------|-------------------|------------------------|------------------------------|----------|
| 6 | 6 | 4,4 | 21 | 36 | 46,0 | 8,0 | M 6 | 18 | 4,0 | - | 4 | - | 13 | 16 |
| 8 | 8 | 6,0 | 24 | 42 | 54,0 | 10,2 | M 8 | 22 | 7,4 | - | 7 | - | 15 | 28 |
| 10 | 9 | 7,0 | 29 | 48 | 62,0 | 13,2 | M 10 | 26 | 11,6 | - | 10 | - | 12 | 50 |
| 12 | 10 | 8,0 | 34 | 54 | 71,0 | 14,9 | M 12 | 28 | 17,0 | - | 14 | - | 11 | 86 |
| 15 | 12 | 10,0 | 40 | 63 | 83,0 | 18,4 | M 14 | 34 | 23,0 | - | 30 | - | 8 | 140 |
| 16 | 14 | 11,0 | 46 | 69 | 92,0 | 20,7 | M 16 | 36 | 31,5 | - | 39 | - | 10 | 190 |
| 17 | 14 | 11,0 | 46 | 69 | 92,0 | 20,7 | M 16 | 36 | 31,5 | - | 39 | - | 10 | 190 |
| 20 | 16 | 13,0 | 53 | 78 | 104,5 | 24,2 | M 20x1,5 | 43 | 45,0 | - | 54 | - | 9 | 320 |
| 25 | 20 | 17,0 | 64 | 94 | 126,0 | 29,3 | M 24x2 | 53 | 73,0 | 73 | 96 | 78 | 7 | 570 |
| 30 | 22 | 19,0 | 73 | 110 | 146,5 | 34,2 | M 30x2 | 65 | 97,0 | 97 | 118 | 89 | 6 | 890 |
| 35 | 25 | 21,0 | 82 | 140 | 181,0 | 39,8 | M 36x3 | 82 | 111,0 | 111 | 153 | 124 | 6 | 1400 |
| 40 | 28 | 23,0 | 92 | 150 | 196,0 | 45,0 | M 39x3 | 86 | 135,0 | 135 | 190 | 158 | 7 | 1800 |
| 45 ¹⁾ | 32 | 27,0 | 102 | 163 | 214,0 | 50,8 | M 42x3 | 94 | 178,0 | 178 | 247 | 202 | 7 | 2610 |
| 50 | 35 | 30,0 | 112 | 185 | 241,0 | 56,0 | M 45x3 | 107 | 216,0 | 216 | 308 | 261 | 6 | 3450 |
| 60 ¹⁾ | 44 | 38,0 | 135 | 210 | 277,5 | 66,8 | M 52x3 | 115 | 336,0 | 336 | 481 | 413 | 6 | 5900 |
| 70 ¹⁾ | 49 | 42,0 | 160 | 235 | 315,0 | 77,9 | M 56x4 | 125 | 429,0 | 429 | 619 | 558 | 6 | 8200 |
| 80 ¹⁾ | 55 | 47,0 | 180 | 270 | 360,0 | 89,4 | M 64x4 | 140 | 570,0 | 570 | 792 | 712 | 6 | 12000 |

Materials:

Housing: from size 6 to 40 stainless steel to 1.4301, Aisi 304, forged, polished
from size 45 stainless steel to 1.4301, Aisi 304, turned
from size 50 stainless steel to 1.4571, Aisi 316Ti, turned

Bearing: maintenance free stainless steel Spherical Plain Bearing GE...EC-NIRO (-2RSF) (see page 71)
from size 25 available sealed from both sides (-2RS)

¹⁾ availability and price on request

Spherical Plain Bearings Series E - Steel on Steel

Series GE...E (-2RS)

Spherical Plain Bearings
steel on steel, treated
with molybdenum disulphide
mos2, regreasable

For use with high multi-
directional loads

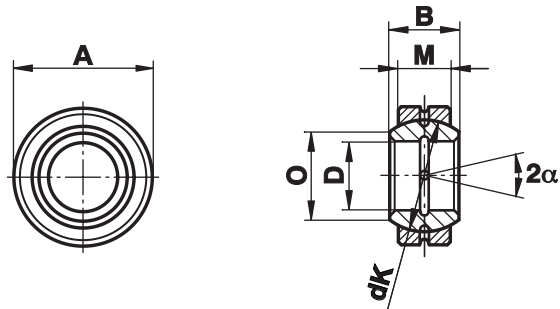

| Size (D) | B | M | A | O | dK | Static load C ₀ kN | Dynamic load C kN | Maximum Pivoting Angle α (°) | Weight g |
|------------------------------------|-----|-----|-----------------------|-------|-------|-------------------------------|-------------------|------------------------------|----------|
| 4 ¹⁾ _{-0,008} | 5 | 3 | 12 _{-0,008} | 6,0 | 8,0 | 10,0 | 2,0 | 16 | 3 |
| 5 ¹⁾ _{-0,008} | 6 | 4 | 14 _{-0,008} | 8,0 | 10,0 | 17,0 | 3,4 | 13 | 4 |
| 6 ¹⁾ _{-0,008} | 6 | 4 | 14 _{-0,008} | 8,0 | 10,0 | 17,0 | 3,4 | 13 | 4 |
| 8 ¹⁾ _{-0,008} | 8 | 5 | 16 _{-0,008} | 10,2 | 13,0 | 27,5 | 5,5 | 15 | 7 |
| 10 ¹⁾ _{-0,008} | 9 | 6 | 19 _{-0,009} | 13,2 | 16,0 | 40,5 | 8,1 | 12 | 11 |
| 12 ¹⁾ _{-0,008} | 10 | 7 | 22 _{-0,009} | 14,9 | 18,0 | 54,0 | 10,8 | 11 | 17 |
| 15 _{-0,008} | 12 | 9 | 26 _{-0,009} | 18,4 | 22,0 | 85,0 | 17,0 | 8 | 26 |
| 16 ²⁾ _{-0,008} | 14 | 10 | 30 _{-0,009} | 20,7 | 25,0 | 106,0 | 21,2 | 10 | 40 |
| 17 _{-0,008} | 14 | 10 | 30 _{-0,009} | 20,7 | 25,0 | 106,0 | 21,2 | 10 | 40 |
| 20 _{-0,010} | 16 | 12 | 35 _{-0,011} | 24,1 | 29,0 | 146,0 | 30,0 | 9 | 64 |
| 25 _{-0,010} | 20 | 16 | 42 _{-0,011} | 29,3 | 35,5 | 240,0 | 48,0 | 7 | 115 |
| 30 _{-0,010} | 22 | 18 | 47 _{-0,011} | 34,2 | 40,7 | 310,0 | 62,0 | 6 | 149 |
| 35 _{-0,012} | 25 | 20 | 55 _{-0,013} | 39,7 | 47,0 | 400,0 | 80,0 | 6 | 228 |
| 40 _{-0,012} | 28 | 22 | 62 _{-0,013} | 45,0 | 53,0 | 500,0 | 100,0 | 7 | 318 |
| 45 _{-0,012} | 32 | 25 | 68 _{-0,013} | 50,7 | 60,0 | 640,0 | 127,0 | 7 | 421 |
| 50 _{-0,012} | 35 | 28 | 75 _{-0,013} | 55,9 | 66,0 | 780,0 | 156,0 | 6 | 562 |
| 55 _{-0,015} | 40 | 32 | 85 _{-0,015} | 62,3 | 74,0 | 1000,0 | 200,0 | 7 | 864 |
| 60 _{-0,015} | 44 | 36 | 90 _{-0,015} | 66,8 | 80,0 | 1220,0 | 245,0 | 6 | 1030 |
| 70 _{-0,015} | 49 | 40 | 105 _{-0,015} | 77,8 | 92,0 | 1560,0 | 315,0 | 6 | 1570 |
| 80 _{-0,015} | 55 | 45 | 120 _{-0,015} | 89,4 | 105,0 | 2000,0 | 400,0 | 6 | 2320 |
| 90 _{-0,020} | 60 | 50 | 130 _{-0,018} | 98,1 | 115,0 | 2450,0 | 490,0 | 5 | 2790 |
| 100 _{-0,020} | 70 | 55 | 150 _{-0,018} | 109,5 | 130,0 | 3050,0 | 610,0 | 7 | 4440 |
| 110 _{-0,020} | 70 | 55 | 160 _{-0,025} | 121,2 | 140,0 | 3250,0 | 655,0 | 6 | 4830 |
| 120 _{-0,020} | 85 | 70 | 180 _{-0,025} | 135,5 | 160,0 | 4750,0 | 950,0 | 6 | 8110 |
| 140 _{-0,025} | 90 | 70 | 210 _{-0,030} | 155,8 | 180,0 | 5400,0 | 1080,0 | 7 | 11200 |
| 160 _{-0,025} | 105 | 80 | 230 _{-0,030} | 170,2 | 200,0 | 6800,0 | 1370,0 | 8 | 14100 |
| 180 _{-0,025} | 105 | 80 | 260 _{-0,035} | 198,9 | 225,0 | 7650,0 | 1530,0 | 6 | 18500 |
| 200 _{-0,030} | 130 | 100 | 290 _{-0,035} | 213,5 | 250,0 | 10600,0 | 2120,0 | 7 | 28400 |
| 220 _{-0,030} | 135 | 100 | 320 _{-0,040} | 239,5 | 275,0 | 11600,0 | 2320,0 | 8 | 35700 |
| 240 _{-0,030} | 140 | 100 | 340 _{-0,040} | 265,3 | 300,0 | 12700,0 | 2550,0 | 8 | 39700 |
| 260 _{-0,035} | 150 | 110 | 370 _{-0,040} | 288,3 | 325,0 | 15300,0 | 3050,0 | 7 | 51500 |
| 280 _{-0,035} | 155 | 120 | 400 _{-0,040} | 313,8 | 350,0 | 18000,0 | 3550,0 | 6 | 64900 |
| 300 _{-0,035} | 165 | 120 | 430 _{-0,045} | 336,7 | 375,0 | 19000,0 | 3800,0 | 7 | 77600 |

Materials:

Insert: Bearing steel to 100Cr6, Aisi 52100, hardened, ground, phosphated, treated with molybdenum disulphide from size 15 available sealed from both sides (-2RS)
from size 220 only available sealed from both sides (-2RS)

Ball: Bearing steel to 100Cr6, Aisi 52100, hardened, ground, phosphated, treated with molybdenum disulphide

- 1) without lubrication hole
- 2) also available with outside diameter 28 mm

FLURO®-Gelenklager GmbH

Spherical Plain Bearings - Steel on Steel

Series GE...HO-2RS

Spherical Plain Bearings steel on steel, regreasable with lip seal on both sides.
Dimensions identical to series GE...E (-2RS) but ball with shoulder

Through the ball with shoulder no distance rings are required

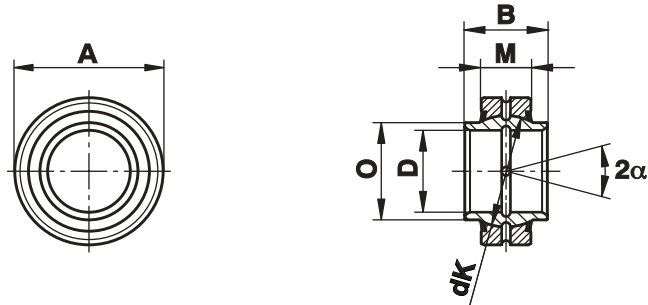

| Size (D) | B | M | A | O | dK | Static load C ₀ kN | Dynamic load C kN | Maximum Pivoting Angle α (°) | Weight g |
|---|-----|----|---|-------|-------|-------------------------------|-------------------|------------------------------|----------|
| 16 ²⁾ $\begin{smallmatrix} 0 \\ -0,008 \end{smallmatrix}$ | 21 | 10 | 30 $\begin{smallmatrix} 0 \\ -0,009 \end{smallmatrix}$ | 21,0 | 25,0 | 106 | 21,2 | 3 | 44 |
| 17 $\begin{smallmatrix} 0 \\ -0,008 \end{smallmatrix}$ | 21 | 10 | 30 $\begin{smallmatrix} 0 \\ -0,009 \end{smallmatrix}$ | 21,0 | 25,0 | 106 | 21,2 | 3 | 44 |
| 20 $\begin{smallmatrix} 0 \\ -0,010 \end{smallmatrix}$ | 24 | 12 | 35 $\begin{smallmatrix} 0 \\ -0,011 \end{smallmatrix}$ | 24,0 | 29,0 | 146 | 30,0 | 6 | 72 |
| 25 $\begin{smallmatrix} 0 \\ -0,010 \end{smallmatrix}$ | 29 | 16 | 42 $\begin{smallmatrix} 0 \\ -0,011 \end{smallmatrix}$ | 29,0 | 35,5 | 240 | 48,0 | 4 | 130 |
| 30 $\begin{smallmatrix} 0 \\ -0,010 \end{smallmatrix}$ | 30 | 18 | 47 $\begin{smallmatrix} 0 \\ -0,011 \end{smallmatrix}$ | 34,2 | 40,7 | 310 | 62,0 | 4 | 160 |
| 35 $\begin{smallmatrix} 0 \\ -0,012 \end{smallmatrix}$ | 35 | 20 | 55 $\begin{smallmatrix} 0 \\ -0,013 \end{smallmatrix}$ | 40,0 | 47,0 | 400 | 80,0 | 4 | 250 |
| 40 $\begin{smallmatrix} 0 \\ -0,012 \end{smallmatrix}$ | 38 | 22 | 62 $\begin{smallmatrix} 0 \\ -0,013 \end{smallmatrix}$ | 45,0 | 53,0 | 500 | 100,0 | 4 | 340 |
| 45 $\begin{smallmatrix} 0 \\ -0,012 \end{smallmatrix}$ | 40 | 25 | 68 $\begin{smallmatrix} 0 \\ -0,013 \end{smallmatrix}$ | 51,5 | 60,0 | 640 | 127,0 | 4 | 450 |
| 50 $\begin{smallmatrix} 0 \\ -0,012 \end{smallmatrix}$ | 43 | 28 | 75 $\begin{smallmatrix} 0 \\ -0,013 \end{smallmatrix}$ | 56,5 | 66,0 | 780 | 156,0 | 4 | 590 |
| 60 $\begin{smallmatrix} 0 \\ -0,015 \end{smallmatrix}$ | 54 | 36 | 90 $\begin{smallmatrix} 0 \\ -0,015 \end{smallmatrix}$ | 67,7 | 80,0 | 1220 | 245,0 | 3 | 1060 |
| 70 $\begin{smallmatrix} 0 \\ -0,015 \end{smallmatrix}$ | 65 | 40 | 105 $\begin{smallmatrix} 0 \\ -0,015 \end{smallmatrix}$ | 78,0 | 92,0 | 1560 | 315,0 | 4 | 1660 |
| 80 $\begin{smallmatrix} 0 \\ -0,015 \end{smallmatrix}$ | 74 | 45 | 120 $\begin{smallmatrix} 0 \\ -0,015 \end{smallmatrix}$ | 90,0 | 105,0 | 2000 | 400,0 | 4 | 2470 |
| 90 ¹⁾ $\begin{smallmatrix} 0 \\ -0,020 \end{smallmatrix}$ | 80 | 50 | 130 $\begin{smallmatrix} 0 \\ -0,018 \end{smallmatrix}$ | 99,0 | 115,0 | 2440 | 488,0 | 4 | 2880 |
| 100 ¹⁾ $\begin{smallmatrix} 0 \\ -0,020 \end{smallmatrix}$ | 90 | 55 | 150 $\begin{smallmatrix} 0 \\ -0,018 \end{smallmatrix}$ | 113,0 | 130,0 | 3030 | 607,0 | 4 | 4650 |
| 120 ¹⁾ $\begin{smallmatrix} 0 \\ -0,020 \end{smallmatrix}$ | 108 | 70 | 180 $\begin{smallmatrix} 0 \\ -0,025 \end{smallmatrix}$ | 133,0 | 160,0 | 4750 | 950,0 | 4 | 8440 |

Materials:

Insert: Bearing steel to 100Cr6, Aisi 52100, hardened, ground, phosphated treated with molybdenum disulphide

Ball: Bearing steel to 100Cr6, Aisi 52100, hardened, ground, phosphated treated with molybdenum disulphide

- 1) Price and availability on request
2) without -2RS seals

Spherical Plain Bearings Series E- Steel on Steel - inch-sized

Series

GE..ZO (-2RS)

Steel on Steel Spherical Plain Bearing, requiring maintenance, inch-sized

For use with high multidirectional loads

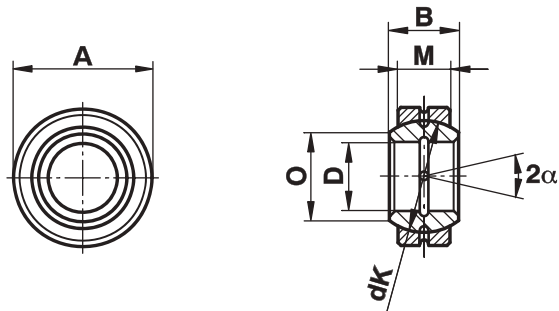

| Size | D | B | M | A | dK | Static load C ₀ kN | Dynamic load C kN | Maximum Pivoting Angle α (°) | Weight g |
|------|---------------------------------------|--------|--------|--|---------|----------------------------------|----------------------|------------------------------|----------|
| 12 | 12,700 ⁰ _{-0,008} | 11,100 | 9,525 | 22,225 ⁰ _{-0,009} | 18,000 | 41 | 13 | 6 | 22 |
| | 0,500 | 0,437 | 0,375 | 0,8750 | 0,709 | | | | |
| 15 | 15,875 ⁰ _{-0,008} | 13,894 | 11,913 | 26,988 ⁰ _{-0,009} | 23,000 | 65 | 22 | 6 | 36 |
| | 0,625 | 0,547 | 0,469 | 1,0625 | 0,906 | | | | |
| 19 | 19,050 ⁰ _{-0,010} | 16,662 | 14,275 | 31,750 ⁰ _{-0,011} | 27,500 | 95 | 31 | 6 | 53 |
| | 0,750 | 0,656 | 0,562 | 1,2500 | 1,083 | | | | |
| 22 | 22,225 ⁰ _{-0,010} | 19,431 | 16,662 | 36,513 ⁰ _{-0,011} | 32,000 | 127 | 42 | 6 | 85 |
| | 0,875 | 0,765 | 0,656 | 1,4375 | 1,260 | | | | |
| 25 | 25,400 ⁰ _{-0,010} | 22,225 | 19,050 | 41,275 ⁰ _{-0,011} | 36,500 | 166 | 56 | 6 | 121 |
| | 1,000 | 0,875 | 0,750 | 1,6250 | 1,437 | | | | |
| 31 | 31,750 ⁰ _{-0,012} | 27,762 | 23,800 | 50,800 ⁰ _{-0,013} | 45,500 | 260 | 86 | 6 | 230 |
| | 1,250 | 1,093 | 0,937 | 2,0000 | 1,791 | | | | |
| 34 | 34,925 ⁰ _{-0,012} | 30,150 | 26,187 | 55,563 ⁰ _{-0,013} | 49,000 | 310 | 102 | 5 | 350 |
| | 1,375 | 1,187 | 1,031 | 2,1875 | 1,929 | | | | |
| 38 | 38,100 ⁰ _{-0,012} | 33,325 | 28,575 | 61,913 ⁰ _{-0,013} | 54,700 | 375 | 125 | 6 | 420 |
| | 1,500 | 1,312 | 1,125 | 2,4375 | 2,154 | | | | |
| 44 | 44,450 ⁰ _{-0,012} | 38,887 | 33,325 | 71,438 ⁰ _{-0,013} | 63,900 | 510 | 170 | 6 | 640 |
| | 1,750 | 1,531 | 1,312 | 2,8125 | 2,516 | | | | |
| 50 | 50,800 ⁰ _{-0,015} | 44,450 | 38,100 | 80,963 ⁰ _{-0,015} | 73,000 | 670 | 224 | 6 | 930 |
| | 2,000 | 1,750 | 1,500 | 3,1875 | 2,874 | | | | |
| 57 | 57,150 ⁰ _{-0,015} | 50,013 | 42,850 | 90,488 ⁰ _{-0,015} | 82,000 | 850 | 280 | 6 | 1300 |
| | 2,250 | 1,969 | 1,687 | 3,5625 | 3,228 | | | | |
| 63 | 63,500 ⁰ _{-0,015} | 55,550 | 47,625 | 100,013 ⁰ _{-0,015} | 92,000 | 1060 | 355 | 6 | 1850 |
| | 2,500 | 2,187 | 1,875 | 3,9375 | 3,622 | | | | |
| 69 | 69,850 ⁰ _{-0,015} | 61,112 | 52,375 | 111,125 ⁰ _{-0,015} | 100,000 | 1250 | 415 | 6 | 2400 |
| | 2,750 | 2,406 | 2,062 | 4,3750 | 3,937 | | | | |
| 76 | 76,200 ⁰ _{-0,015} | 66,675 | 57,150 | 120,650 ⁰ _{-0,018} | 109,500 | 1500 | 500 | 6 | 3100 |
| | 3,000 | 2,625 | 2,250 | 4,7500 | 4,311 | | | | |
| 82 | 82,550 ⁰ _{-0,020} | 72,238 | 61,900 | 130,175 ⁰ _{-0,018} | 119,000 | 1760 | 585 | 6 | 3800 |
| | 3,250 | 2,844 | 2,437 | 5,1250 | 4,685 | | | | |
| 88 | 88,900 ⁰ _{-0,020} | 77,775 | 66,675 | 139,700 ⁰ _{-0,018} | 128,000 | 2040 | 680 | 6 | 4800 |
| | 3,500 | 3,062 | 2,625 | 5,5000 | 5,039 | | | | |
| 95 | 95,250 ⁰ _{-0,020} | 83,337 | 71,425 | 149,225 ⁰ _{-0,015} | 137,000 | 2360 | 780 | 6 | 5800 |
| | 3,750 | 3,281 | 2,812 | 5,8750 | 5,394 | | | | |

Spherical Plain Bearings Series E- Steel on Steel - inch-sized

| Size | D | B | M | A | dK | Static load C ₀ kN | Dynamic load C kN | Maximum Pivoting Angle α (°) | Weight g |
|------|---------------------------------------|---------|---------|--|---------|----------------------------------|----------------------|------------------------------|----------|
| 101 | 101,60 ⁰ _{-0,020} | 88,900 | 76,200 | 158,750 ⁰ _{-0,025} | 146,000 | 2650 | 900 | 6 | 7000 |
| | 4,00 | 3,500 | 3,000 | 6,250 | 5,748 | | | | |
| 107 | 107,95 ⁰ _{-0,020} | 94,463 | 80,950 | 168,275 ⁰ _{-0,025} | 155,000 | 3000 | 1000 | 6 | 8400 |
| | 4,25 | 3,719 | 3,187 | 6,625 | 6,102 | | | | |
| 114 | 114,30 ⁰ _{-0,020} | 100,013 | 85,725 | 177,800 ⁰ _{-0,025} | 164,500 | 3400 | 1120 | 6 | 9800 |
| | 4,50 | 3,937 | 3,375 | 7,000 | 6,476 | | | | |
| 120 | 120,65 ⁰ _{-0,025} | 105,562 | 90,475 | 187,325 ⁰ _{-0,030} | 173,500 | 3750 | 1250 | 6 | 11500 |
| | 4,75 | 4,156 | 3,562 | 7,375 | 6,831 | | | | |
| 127 | 127,00 ⁰ _{-0,025} | 111,125 | 95,250 | 196,850 ⁰ _{-0,030} | 183,000 | 4150 | 1400 | 6 | 13500 |
| | 5,00 | 4,375 | 3,750 | 7,750 | 7,205 | | | | |
| 152 | 152,40 ⁰ _{-0,025} | 120,650 | 104,775 | 222,250 ⁰ _{-0,030} | 207,000 | 5200 | 1730 | 5 | 17500 |
| | 6,00 | 4,750 | 4,125 | 8,750 | 8,150 | | | | |
| 165 | 165,10 ⁰ _{-0,025} | 123,825 | 103,175 | 247,650 ⁰ _{-0,030} | 223,000 | 5500 | 1830 | 7 | 22900 |
| | 6,50 | 4,875 | 4,062 | 9,750 | 8,780 | | | | |
| 177 | 177,80 ⁰ _{-0,025} | 133,350 | 111,125 | 266,700 ⁰ _{-0,035} | 240,000 | 6390 | 2120 | 7 | 28600 |
| | 7,00 | 5,250 | 4,375 | 10,500 | 9,449 | | | | |
| 190 | 190,50 ⁰ _{-0,030} | 142,875 | 119,050 | 285,750 ⁰ _{-0,035} | 257,000 | 7340 | 2440 | 7 | 35100 |
| | 7,50 | 5,625 | 4,687 | 11,250 | 10,118 | | | | |
| 203 | 203,50 ⁰ _{-0,030} | 152,400 | 127,000 | 304,800 ⁰ _{-0,035} | 275,000 | 8350 | 2770 | 7 | 42600 |
| | 8,00 | 6,000 | 5,000 | 12,000 | 10,827 | | | | |
| 215 | 215,90 ⁰ _{-0,030} | 161,925 | 134,925 | 323,850 ⁰ _{-0,040} | 292,000 | 9420 | 3130 | 7 | 51100 |
| | 8,50 | 6,375 | 5,312 | 12,750 | 11,496 | | | | |
| 228 | 228,60 ⁰ _{-0,030} | 171,450 | 142,750 | 342,900 ⁰ _{-0,040} | 309,000 | 10500 | 3510 | 7 | 60700 |
| | 9,00 | 6,750 | 5,625 | 13,500 | 12,165 | | | | |
| 241 | 241,30 ⁰ _{-0,030} | 180,975 | 150,800 | 361,950 ⁰ _{-0,040} | 326,000 | 11700 | 3910 | 7 | 71400 |
| | 9,50 | 7,125 | 5,937 | 14,250 | 12,835 | | | | |
| 254 | 254,00 ⁰ _{-0,035} | 190,500 | 158,750 | 381,000 ⁰ _{-0,040} | 343,000 | 13050 | 4340 | 7 | 83300 |
| | 10,00 | 7,500 | 6,250 | 15,000 | 13,504 | | | | |
| 266 | 266,70 ⁰ _{-0,035} | 200,250 | 166,675 | 400,050 ⁰ _{-0,045} | 360,000 | 14300 | 4780 | 7 | 96400 |
| | 10,50 | 7,875 | 6,562 | 15,750 | 14,173 | | | | |
| 279 | 279,40 ⁰ _{-0,035} | 209,550 | 174,625 | 419,100 ⁰ _{-0,045} | 377,000 | 15700 | 5250 | 7 | 110800 |
| | 11,00 | 8,250 | 6,875 | 16,500 | 14,843 | | | | |
| 292 | 292,10 ⁰ _{-0,035} | 219,075 | 182,550 | 438,150 ⁰ _{-0,045} | 395,000 | 17200 | 5740 | 7 | 126700 |
| | 11,50 | 8,625 | 7,187 | 17,250 | 15,551 | | | | |
| 304 | 304,80 ⁰ _{-0,035} | 288,600 | 190,500 | 457,200 ⁰ _{-0,045} | 412,000 | 18700 | 6250 | 7 | 143900 |
| | 12,00 | 9,000 | 7,500 | 18,000 | 16,220 | | | | |

Materials:

Insert: Bearing steel to 100Cr6, Aisi 52100, hardened, ground, phosphated treated with molybdenum disulphide from size 19 available sealed from both sides (-2RS)

Ball: Bearing steel to 100Cr6, Aisi 52100, hardened, ground, phosphated treated with molybdenum disulphide

Spherical Plain Bearings Series W - Steel on Steel

Series GE...LO

Spherical Plain Bearings
steel on steel series W
to DIN ISO 12240-1,
treated with molyb-
denum disulphide mos2,
regreasable

For use on standard
Hydraulic Cylinders to
DIN 24333 and to DIN
24336 with floor piece
or piston rod relays

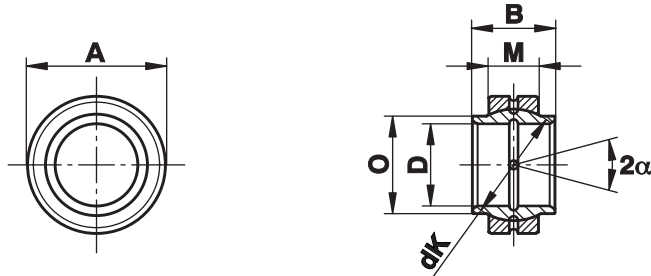

| Size (D) | B | M | A | O | dK | Static load C ₀ kN | Dynamic load C kN | Maximum Pivoting Angle α (°) | Weight g |
|---|-----|-----|------------------------------------|-------|-------|-------------------------------|-------------------|------------------------------|----------|
| 12 ¹⁾ _{+0,018} ⁰ | 12 | 7 | 22 _{-0,009} ⁰ | 15,5 | 18,0 | 54 | 10,8 | 4 | 17 |
| 15 _{+0,018} ⁰ | 15 | 9 | 26 _{-0,009} ⁰ | 18,5 | 22,0 | 84 | 16,0 | 5 | 28 |
| 16 _{+0,018} ⁰ | 16 | 9 | 28 _{-0,009} ⁰ | 20,0 | 23,0 | 88 | 17,6 | 4 | 34 |
| 17 _{+0,018} ⁰ | 17 | 10 | 30 _{-0,011} ⁰ | 21,0 | 25,0 | 106 | 21,0 | 7 | 43 |
| 20 _{+0,021} ⁰ | 20 | 12 | 35 _{-0,011} ⁰ | 25,0 | 29,0 | 146 | 30,0 | 4 | 69 |
| 25 _{+0,021} ⁰ | 25 | 16 | 42 _{-0,011} ⁰ | 30,5 | 35,5 | 240 | 48,0 | 4 | 124 |
| 30 _{+0,021} ⁰ | 30 | 18 | 47 _{-0,011} ⁰ | 34,0 | 40,7 | 310 | 62,0 | 4 | 159 |
| 32 _{+0,025} ⁰ | 32 | 18 | 52 _{-0,013} ⁰ | 37,0 | 43,0 | 335 | 67,0 | 4 | 207 |
| 35 _{+0,025} ⁰ | 35 | 20 | 55 _{-0,013} ⁰ | 40,0 | 47,0 | 399 | 79,0 | 4 | 248 |
| 40 _{+0,025} ⁰ | 40 | 22 | 62 _{-0,013} ⁰ | 46,0 | 53,0 | 500 | 100,0 | 4 | 349 |
| 45 _{+0,025} ⁰ | 45 | 25 | 68 _{-0,013} ⁰ | 52,0 | 60,0 | 637 | 127,0 | 4 | 468 |
| 50 _{+0,025} ⁰ | 50 | 28 | 75 _{-0,013} ⁰ | 57,0 | 66,0 | 780 | 156,0 | 4 | 620 |
| 60 _{+0,030} ⁰ | 60 | 36 | 90 _{-0,015} ⁰ | 68,0 | 80,0 | 1220 | 245,0 | 4 | 1110 |
| 63 _{+0,030} ⁰ | 63 | 36 | 95 _{-0,015} ⁰ | 71,5 | 83,0 | 1270 | 255,0 | 4 | 1270 |
| 70 _{+0,030} ⁰ | 70 | 40 | 105 _{-0,015} ⁰ | 79,0 | 92,0 | 1560 | 315,0 | 4 | 1690 |
| 80 _{+0,030} ⁰ | 80 | 45 | 120 _{-0,015} ⁰ | 91,0 | 105,0 | 2000 | 400,0 | 4 | 2550 |
| 90 _{+0,035} ⁰ | 90 | 50 | 130 _{-0,018} ⁰ | 99,0 | 115,0 | 2450 | 490,0 | 4 | 3040 |
| 100 _{+0,035} ⁰ | 100 | 55 | 150 _{-0,018} ⁰ | 113,0 | 130,0 | 3050 | 610,0 | 4 | 4870 |
| 110 _{+0,035} ⁰ | 110 | 55 | 160 _{-0,025} ⁰ | 124,0 | 140,0 | 3250 | 655,0 | 4 | 5530 |
| 125 _{+0,040} ⁰ | 125 | 70 | 180 _{-0,025} ⁰ | 138,0 | 160,0 | 4750 | 950,0 | 4 | 8190 |
| 160 _{+0,040} ⁰ | 160 | 80 | 230 _{-0,030} ⁰ | 177,0 | 200,0 | 6800 | 1370,0 | 4 | 15800 |
| 200 _{+0,046} ⁰ | 200 | 100 | 290 _{-0,035} ⁰ | 221,0 | 250,0 | 10600 | 2120,0 | 4 | 31700 |
| 250 _{+0,046} ⁰ | 250 | 120 | 400 _{-0,040} ⁰ | 317,0 | 350,0 | 18000 | 3550,0 | 4 | 101000 |
| 320 _{+0,057} ⁰ | 320 | 160 | 520 _{-0,050} ⁰ | 405,0 | 450,0 | 30500 | 6100,0 | 4 | 225000 |

Materials:

Insert: Bearing steel to 100Cr6, Aisi 52100, hardened, ground, phosphated treated with molybdenum disulphide

Ball: Bearing steel to 100Cr6, Aisi 52100, hardened, ground, phosphated treated with molybdenum disulphide

¹⁾ lubrication groove in the insert only

Spherical Plain Bearings Series G - Steel on Steel

Series GE...FO (-2RS)

Spherical Plain Bearings
steel on steel series G
to DIN ISO 12240-1.
Treated with molybdenum disulphide mos2,
regreasable

For use with higher
pivoting angle

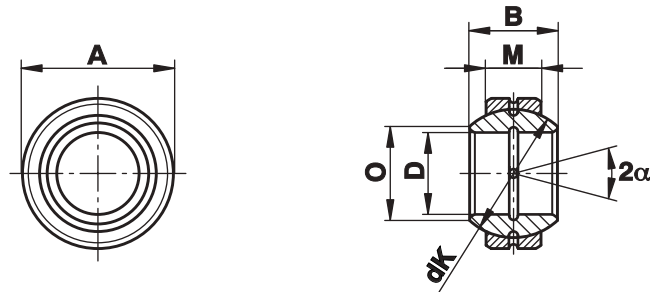

| Size (D) | B | M | A | O | dK | Static load C ₀ kN | Dynamic load C kN | Maximum Pivoting Angle α (°) | Weight g |
|------------------------------------|-----|-----|-----------------------|-------|-------|-------------------------------|-------------------|------------------------------|----------|
| 4 ¹⁾ _{-0,008} | 7 | 4 | 14 _{-0,008} | 7,1 | 10,0 | 17,0 | 3,4 | 20 | 5 |
| 5 ¹⁾ _{-0,008} | 9 | 5 | 16 _{-0,008} | 9,3 | 13,0 | 27,0 | 5,5 | 21 | 8 |
| 6 ¹⁾ _{-0,008} | 9 | 5 | 16 _{-0,008} | 9,3 | 13,0 | 27,5 | 5,5 | 21 | 8 |
| 8 ¹⁾ _{-0,008} | 11 | 6 | 19 _{-0,009} | 11,6 | 16,0 | 40,5 | 8,1 | 21 | 14 |
| 10 ¹⁾ _{-0,008} | 12 | 7 | 22 _{-0,009} | 13,4 | 18,0 | 54,0 | 10,8 | 18 | 21 |
| 12 ¹⁾ _{-0,008} | 15 | 9 | 26 _{-0,009} | 16,0 | 22,0 | 85,0 | 17,0 | 18 | 36 |
| 15 _{-0,008} | 16 | 10 | 30 _{-0,009} | 19,2 | 25,0 | 106,0 | 21,2 | 16 | 48 |
| 17 _{-0,008} | 20 | 12 | 35 _{-0,011} | 21,0 | 29,0 | 146,0 | 30,0 | 19 | 80 |
| 20 _{-0,010} | 25 | 16 | 42 _{-0,011} | 25,2 | 35,5 | 240,0 | 48,0 | 17 | 152 |
| 25 _{-0,010} | 28 | 18 | 47 _{-0,011} | 29,5 | 40,7 | 310,0 | 62,0 | 17 | 199 |
| 30 _{-0,010} | 32 | 20 | 55 _{-0,013} | 34,4 | 47,0 | 400,0 | 80,0 | 17 | 296 |
| 35 _{-0,012} | 35 | 22 | 62 _{-0,013} | 39,7 | 53,0 | 500,0 | 100,0 | 16 | 402 |
| 40 _{-0,012} | 40 | 25 | 68 _{-0,013} | 44,7 | 60,0 | 640,0 | 127,0 | 17 | 535 |
| 45 _{-0,012} | 43 | 28 | 75 _{-0,013} | 50,0 | 66,0 | 780,0 | 156,0 | 15 | 698 |
| 50 _{-0,012} | 56 | 36 | 90 _{-0,015} | 57,1 | 80,0 | 1220,0 | 245,0 | 17 | 1420 |
| 60 _{-0,015} | 63 | 40 | 105 _{-0,015} | 67,0 | 92,0 | 1560,0 | 315,0 | 17 | 2090 |
| 70 _{-0,015} | 70 | 45 | 120 _{-0,015} | 78,2 | 105,0 | 2000,0 | 400,0 | 16 | 3010 |
| 80 _{-0,015} | 75 | 50 | 130 _{-0,018} | 87,1 | 115,0 | 2450,0 | 490,0 | 14 | 3610 |
| 90 _{-0,020} | 85 | 55 | 150 _{-0,018} | 98,3 | 130,0 | 3050,0 | 610,0 | 15 | 5500 |
| 100 _{-0,020} | 85 | 55 | 160 _{-0,025} | 111,2 | 140,0 | 3250,0 | 655,0 | 14 | 6040 |
| 110 _{-0,020} | 100 | 70 | 180 _{-0,025} | 124,8 | 160,0 | 4750,0 | 950,0 | 12 | 9740 |
| 120 _{-0,020} | 115 | 70 | 210 _{-0,030} | 138,4 | 180,0 | 5400,0 | 1080,0 | 16 | 15100 |
| 140 _{-0,025} | 130 | 80 | 230 _{-0,030} | 151,9 | 200,0 | 6800,0 | 1370,0 | 16 | 18900 |
| 160 _{-0,025} | 135 | 80 | 260 _{-0,035} | 180,0 | 225,0 | 7650,0 | 1530,0 | 16 | 24800 |
| 180 _{-0,025} | 155 | 100 | 290 _{-0,035} | 196,1 | 250,0 | 10600,0 | 2120,0 | 14 | 35900 |
| 200 _{-0,030} | 165 | 100 | 320 _{-0,040} | 220,0 | 275,0 | 11600,0 | 2320,0 | 15 | 44900 |
| 220 _{-0,030} | 175 | 100 | 340 _{-0,040} | 243,6 | 300,0 | 12700,0 | 2550,0 | 16 | 50900 |
| 240 _{-0,030} | 190 | 110 | 370 _{-0,040} | 263,6 | 325,0 | 15300,0 | 3050,0 | 15 | 65300 |
| 260 _{-0,035} | 205 | 120 | 400 _{-0,040} | 283,6 | 350,0 | 18000,0 | 3550,0 | 15 | 82000 |
| 280 _{-0,035} | 210 | 120 | 430 _{-0,045} | 310,6 | 375,0 | 19000,0 | 3800,0 | 15 | 96600 |

Materials:

Insert: Bearing steel to 100Cr6, Aisi 52100, hardened, ground, phosphated treated with molybdenum disulphide from size 15 available sealed from both sides (-2RS)

¹⁾ without lubrication hole

Ball: Bearing steel to 100Cr6, Aisi 52100, hardened, ground, phosphated treated with molybdenum disulphide

Spherical Plain Bearings Series G - Maintenance Free

Series GE...FW (-2RS)

Spherical Plain Bearings series G to DIN ISO 12240-1. Mating surface hard chromium/PTFE, maintenance free

Higher pivoting angle through wider ball

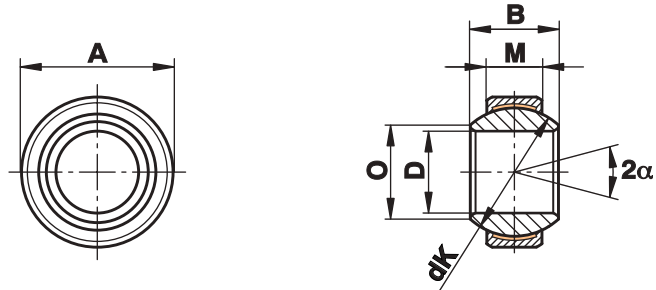

| Size (D) | B | M | A | O | dK | Static load C ₀ kN | Static load C ₀ kN -2RS | Dynamic load C kN | Dynamic load C kN -2RS | Maximum Pivoting Angle α (°) | Weight g |
|-------------------------------------|-----|-----|------------------------------------|-------|-------|-------------------------------|------------------------------------|-------------------|------------------------|------------------------------|----------|
| 4 ⁰ _{-0,008} | 7 | 4 | 14 ⁰ _{-0,008} | 7,1 | 10,0 | 9,1 | - | 3,6 | - | 20 | 5 |
| 5 ⁰ _{-0,008} | 9 | 5 | 16 ⁰ _{-0,008} | 9,3 | 13,0 | 14,0 | - | 5,8 | - | 21 | 8 |
| 6 ⁰ _{-0,008} | 9 | 5 | 16 ⁰ _{-0,008} | 9,3 | 13,0 | 14,0 | - | 5,8 | - | 21 | 9 |
| 8 ⁰ _{-0,008} | 11 | 6 | 19 ⁰ _{-0,009} | 11,6 | 16,0 | 21,0 | - | 8,6 | - | 21 | 14 |
| 10 ⁰ _{-0,008} | 12 | 7 | 22 ⁰ _{-0,009} | 13,4 | 18,0 | 28,0 | - | 11,0 | - | 18 | 21 |
| 12 ⁰ _{-0,008} | 15 | 9 | 26 ⁰ _{-0,009} | 16,0 | 22,0 | 45,0 | - | 18,0 | - | 18 | 33 |
| 15 ⁰ _{-0,008} | 16 | 10 | 30 ⁰ _{-0,009} | 19,2 | 25,0 | 56,0 | 75,0 | 22,0 | 32,0 | 16 | 49 |
| 17 ⁰ _{-0,008} | 20 | 12 | 35 ⁰ _{-0,011} | 21,0 | 29,0 | 78,0 | 104,0 | 31,0 | 45,0 | 19 | 83 |
| 20 ⁰ _{-0,010} | 25 | 16 | 42 ⁰ _{-0,011} | 25,2 | 35,5 | 127,0 | 204,0 | 51,0 | 85,0 | 17 | 153 |
| 25 ⁰ _{-0,010} | 28 | 18 | 47 ⁰ _{-0,011} | 29,5 | 40,7 | 166,0 | 263,0 | 65,0 | 110,0 | 17 | 203 |
| 30 ⁰ _{-0,010} | 32 | 20 | 55 ⁰ _{-0,013} | 34,4 | 47,0 | 211,0 | 338,0 | 84,0 | 140,0 | 17 | 304 |
| 35 ⁰ _{-0,012} | 35 | 22 | 62 ⁰ _{-0,013} | 39,7 | 53,0 | 262,0 | 419,0 | 104,0 | 175,0 | 16 | 408 |
| 40 ⁰ _{-0,012} | 40 | 25 | 68 ⁰ _{-0,013} | 44,7 | 60,0 | 337,0 | 540,0 | 135,0 | 225,0 | 17 | 542 |
| 45 ⁰ _{-0,012} | 43 | 28 | 75 ⁰ _{-0,013} | 50,0 | 66,0 | 415,0 | 665,0 | 166,0 | 275,0 | 15 | 713 |
| 50 ⁰ _{-0,012} | 56 | 36 | 90 ⁰ _{-0,015} | 57,1 | 80,0 | - | 1030,0 | - | 430,0 | 17 | 1420 |
| 60 ⁰ _{-0,015} | 63 | 40 | 105 ⁰ _{-0,015} | 67,0 | 92,0 | - | 1320,0 | - | 550,0 | 17 | 2090 |
| 70 ⁰ _{-0,015} | 70 | 45 | 120 ⁰ _{-0,015} | 78,2 | 105,0 | - | 1700,0 | - | 705,0 | 16 | 3010 |
| 80 ⁰ _{-0,015} | 75 | 50 | 130 ⁰ _{-0,018} | 87,1 | 115,0 | - | 2070,0 | - | 860,0 | 14 | 3610 |
| 90 ⁰ _{-0,020} | 85 | 55 | 150 ⁰ _{-0,018} | 98,3 | 130,0 | - | 2570,0 | - | 1070,0 | 15 | 5500 |
| 100 ⁰ _{-0,020} | 85 | 55 | 160 ⁰ _{-0,025} | 111,2 | 140,0 | - | 2770,0 | - | 1150,0 | 14 | 6040 |
| 110 ⁰ _{-0,020} | 100 | 70 | 180 ⁰ _{-0,025} | 124,8 | 160,0 | - | 4030,0 | - | 1680,0 | 12 | 9740 |
| 120 ⁰ _{-0,020} | 115 | 70 | 210 ⁰ _{-0,030} | 138,4 | 180,0 | - | 4530,0 | - | 1890,0 | 16 | 15100 |
| 140 ¹⁾ _{-0,025} | 130 | 80 | 230 ⁰ _{-0,030} | 151,9 | 200,0 | - | 5760,0 | - | 2400,0 | 16 | 18900 |
| 160 ¹⁾ _{-0,025} | 135 | 80 | 260 ⁰ _{-0,035} | 180,0 | 225,0 | - | 6480,0 | - | 2700,0 | 16 | 24800 |
| 180 ¹⁾ _{-0,025} | 155 | 100 | 290 ⁰ _{-0,035} | 196,1 | 250,0 | - | 9000,0 | - | 3750,0 | 14 | 35900 |
| 200 ¹⁾ _{-0,030} | 165 | 100 | 320 ⁰ _{-0,040} | 220,0 | 275,0 | - | 9900,0 | - | 4120,0 | 15 | 44900 |
| 220 ¹⁾ _{-0,030} | 175 | 100 | 340 ⁰ _{-0,040} | 243,6 | 300,0 | - | 10800,0 | - | 4500,0 | 16 | 50900 |
| 240 ¹⁾ _{-0,030} | 190 | 110 | 370 ⁰ _{-0,040} | 263,6 | 325,0 | - | 12870,0 | - | 5360,0 | 15 | 65300 |
| 260 ¹⁾ _{-0,035} | 205 | 120 | 400 ⁰ _{-0,040} | 283,6 | 350,0 | - | 15120,0 | - | 6300,0 | 15 | 82000 |
| 280 ¹⁾ _{-0,035} | 210 | 120 | 430 ⁰ _{-0,045} | 310,6 | 375,0 | - | 16200,0 | - | 6750,0 | 15 | 96600 |

Materials:

Insert: Bearing steel with PTFE liner bonded to the inner surface
 from size 15 available sealed (-2RS) on both sides
 from size 35 only available sealed (-2RS) on both sides

Ball: Bearing steel to 100Cr6, Aisi 52100, hardened, ground, polished, hard chrome plated on the running surface

1) from size 120 the hardened inserts are two pieced and secured with tension spring

Spherical Plain Bearing Series G - Stainless, maintenance free

Series

GE...FW-NIRO (-2RS)

Spherical Plain Bearing
Series G, Mating surface
NIRO/PTFE,
maintenance free

Increased Maximum
Pivoting Angle through a
wide ball

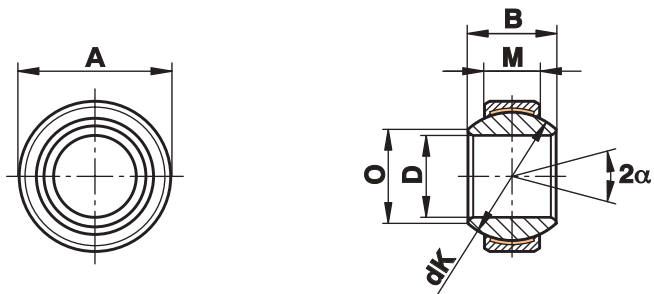

| Size (D) | B | M | A | O | dK | Static load C ₀ kN | Static load C ₀ kN -2RS | Dynamic load C kN | Dynamic load C kN -2RS | Maximum Pivoting Angle α (°) | Weight g |
|------------------------------------|-----|----|------------------------------------|-------|-------|-------------------------------|------------------------------------|-------------------|------------------------|------------------------------|----------|
| 4 ⁰ _{-0,008} | 7 | 4 | 14 ⁰ _{-0,008} | 7,1 | 10,0 | 9,0 | - | 4 | - | 20 | 5 |
| 5 ⁰ _{-0,008} | 9 | 5 | 16 ⁰ _{-0,008} | 9,3 | 13,0 | 15,6 | - | 7 | - | 21 | 8 |
| 6 ⁰ _{-0,008} | 9 | 5 | 16 ⁰ _{-0,008} | 9,3 | 13,0 | 15,6 | - | 7 | - | 21 | 9 |
| 8 ⁰ _{-0,008} | 11 | 6 | 19 ⁰ _{-0,009} | 11,6 | 16,0 | 23,4 | - | 10 | - | 21 | 14 |
| 10 ⁰ _{-0,008} | 12 | 7 | 22 ⁰ _{-0,009} | 13,4 | 18,0 | 32,0 | - | 14 | - | 18 | 21 |
| 12 ⁰ _{-0,008} | 15 | 9 | 26 ⁰ _{-0,009} | 16,0 | 22,0 | 50,0 | - | 30 | - | 18 | 33 |
| 15 ⁰ _{-0,008} | 16 | 10 | 30 ⁰ _{-0,009} | 19,2 | 25,0 | 65,0 | - | 39 | - | 16 | 49 |
| 17 ⁰ _{-0,008} | 20 | 12 | 35 ⁰ _{-0,011} | 21,0 | 29,0 | 90,5 | - | 54 | - | 19 | 83 |
| 20 ⁰ _{-0,010} | 25 | 16 | 42 ⁰ _{-0,011} | 25,2 | 35,5 | 159,0 | 137 | 96 | 78 | 17 | 153 |
| 25 ⁰ _{-0,010} | 28 | 18 | 47 ⁰ _{-0,011} | 29,5 | 40,7 | 197,0 | 155 | 118 | 89 | 17 | 203 |
| 30 ⁰ _{-0,010} | 32 | 20 | 55 ⁰ _{-0,013} | 34,4 | 47,0 | 298,0 | 217 | 153 | 124 | 17 | 304 |
| 35 ⁰ _{-0,012} | 35 | 22 | 62 ⁰ _{-0,013} | 39,7 | 53,0 | 370,6 | 276 | 190 | 158 | 16 | 408 |
| 40 ⁰ _{-0,012} | 40 | 25 | 68 ⁰ _{-0,013} | 44,7 | 60,0 | 481,0 | 353 | 247 | 202 | 17 | 542 |
| 45 ⁰ _{-0,012} | 43 | 28 | 75 ⁰ _{-0,013} | 50,0 | 66,0 | 598,0 | 457 | 308 | 261 | 15 | 713 |
| 50 ⁰ _{-0,012} | 56 | 36 | 90 ⁰ _{-0,015} | 57,1 | 80,0 | 935,0 | 722 | 481 | 413 | 17 | 1420 |
| 60 ⁰ _{-0,015} | 63 | 40 | 105 ⁰ _{-0,015} | 67,0 | 92,0 | 1204,0 | 976 | 619 | 558 | 17 | 2090 |
| 70 ⁰ _{-0,015} | 70 | 45 | 120 ⁰ _{-0,015} | 78,2 | 105,0 | 1540,0 | 1246 | 792 | 712 | 16 | 3010 |
| 80 ⁰ _{-0,015} | 75 | 50 | 130 ⁰ _{-0,018} | 87,1 | 115,0 | 1892,0 | 1525 | 1080 | 872 | 14 | 3610 |
| 90 ⁰ _{-0,020} | 85 | 55 | 150 ⁰ _{-0,018} | 98,3 | 130,0 | 2366,0 | 1997 | 1350 | 1141 | 15 | 5500 |
| 100 ⁰ _{-0,020} | 85 | 55 | 160 ⁰ _{-0,025} | 111,2 | 140,0 | 2548,0 | 2151 | 1460 | 1229 | 14 | 6040 |
| 110 ⁰ _{-0,020} | 100 | 70 | 180 ⁰ _{-0,025} | 124,8 | 160,0 | 3752,0 | 3186 | 2140 | 1821 | 12 | 9740 |

Materials:

Insert: Stainless steel to 1.4571, Aiso 316Ti, with PTFE liner bonded to the inner surface from size 80 with high performance PTFE compound from size 20 available sealed from both sides (-2RSF)

Ball: Stainless steel to 1.4034, hardened, ground, polished

Sealing: H-Ecopur

Angular Contact Spherical Plain Bearings - Steel on Steel

Series GE...SX

Angular Contact Spherical Plain Bearings steel on steel. Treated with molybdenum disulphide mos2, greasable

For use at uni-directional, dynamic radial and additional axial loads

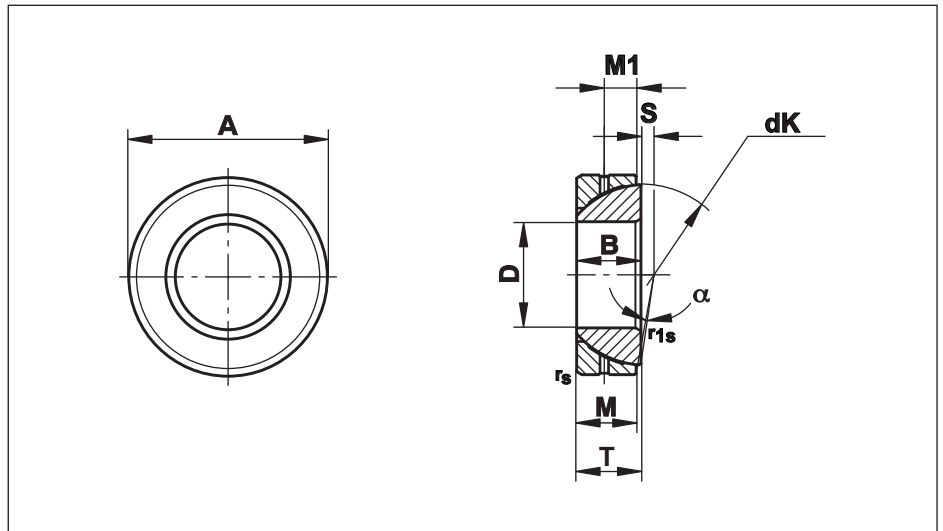

| Size (D) | B | M | A | T | S | M1 | r _s , r _{1s} min | d _k | Radial Load kN | | Maximum Pivoting Angle α (°) | Weight g |
|-------------------------------------|----|------|------------------------------------|--------------------------------------|------|------|--------------------------------------|----------------|-----------------------|-----------|------------------------------|----------|
| | | | | | | | | | Static C ₀ | Dynamic C | | |
| 25 ⁰ _{-0,012} | 15 | 14,0 | 47 ⁰ _{-0,014} | 15 ^{+0,25} _{-0,40} | 0,6 | 7,5 | 1,0 | 42,0 | 250 | 50 | 2,5 | 148 |
| 28 ⁰ _{-0,012} | 15 | 15,0 | 52 ⁰ _{-0,016} | 16 ^{+0,25} _{-0,40} | 1,0 | 8,0 | 1,0 | 47,0 | 300 | 60 | 2,0 | 186 |
| 30 ⁰ _{-0,012} | 17 | 15,0 | 55 ⁰ _{-0,016} | 17 ^{+0,25} _{-0,40} | 1,3 | 8,5 | 1,0 | 49,5 | 315 | 63 | 4,5 | 208 |
| 32 ⁰ _{-0,012} | 17 | 16,0 | 58 ⁰ _{-0,016} | 17 ^{+0,25} _{-0,40} | 2,0 | 8,5 | 1,0 | 52,0 | 354 | 71 | 2,0 | 241 |
| 35 ⁰ _{-0,012} | 18 | 16,0 | 62 ⁰ _{-0,016} | 18 ^{+0,25} _{-0,40} | 2,1 | 9,0 | 1,0 | 55,5 | 390 | 78 | 4,0 | 268 |
| 40 ⁰ _{-0,012} | 19 | 17,0 | 68 ⁰ _{-0,016} | 19 ^{+0,25} _{-0,40} | 2,8 | 9,5 | 1,0 | 62,0 | 463 | 92 | 3,5 | 327 |
| 45 ⁰ _{-0,012} | 20 | 18,0 | 75 ⁰ _{-0,016} | 20 ^{+0,25} _{-0,40} | 3,5 | 10,0 | 1,0 | 68,5 | 540 | 108 | 3,0 | 416 |
| 50 ⁰ _{-0,012} | 20 | 19,0 | 80 ⁰ _{-0,016} | 20 ^{+0,25} _{-0,40} | 4,3 | 10,0 | 1,0 | 74,0 | 618 | 123 | 1,5 | 455 |
| 55 ⁰ _{-0,015} | 23 | 20,0 | 90 ⁰ _{-0,018} | 23 ^{+0,25} _{-0,50} | 5,0 | 11,5 | 1,1 | 82,0 | 721 | 144 | 4,0 | 645 |
| 60 ⁰ _{-0,015} | 23 | 21,0 | 95 ⁰ _{-0,018} | 23 ^{+0,25} _{-0,50} | 5,7 | 11,5 | 1,1 | 88,5 | 817 | 163 | 2,5 | 714 |
| 65 ⁰ _{-0,015} | 23 | 22,0 | 100 ⁰ _{-0,018} | 23 ^{+0,25} _{-0,50} | 6,5 | 11,5 | 1,1 | 93,5 | 905 | 180 | 1,0 | 759 |
| 70 ⁰ _{-0,015} | 25 | 23,0 | 110 ⁰ _{-0,018} | 25 ^{+0,25} _{-0,50} | 7,2 | 12,5 | 1,1 | 102,0 | 1030 | 206 | 2,0 | 1040 |
| 75 ⁰ _{-0,015} | 25 | 24,0 | 115 ⁰ _{-0,018} | 25 ^{+0,25} _{-0,50} | 7,9 | 12,5 | 1,1 | 107,0 | 1129 | 220 | 1,0 | 1120 |
| 80 ⁰ _{-0,015} | 29 | 25,5 | 125 ⁰ _{-0,020} | 29 ^{+0,25} _{-0,50} | 8,6 | 14,5 | 1,1 | 115,0 | 1290 | 258 | 3,5 | 1540 |
| 85 ⁰ _{-0,020} | 29 | 26,5 | 130 ⁰ _{-0,020} | 29 ^{+0,25} _{-0,60} | 9,4 | 14,5 | 1,1 | 122,0 | 1422 | 284 | 2,0 | 1610 |
| 90 ⁰ _{-0,020} | 32 | 28,0 | 140 ⁰ _{-0,020} | 32 ^{+0,25} _{-0,60} | 10,1 | 16,0 | 1,5 | 128,5 | 1580 | 316 | 3,5 | 2090 |
| 95 ⁰ _{-0,020} | 32 | 29,5 | 145 ⁰ _{-0,020} | 32 ^{+0,25} _{-0,60} | 10,8 | 16,0 | 1,5 | 135,0 | 1750 | 350 | 2,0 | 2220 |
| 100 ⁰ _{-0,020} | 32 | 31,0 | 150 ⁰ _{-0,020} | 32 ^{+0,25} _{-0,60} | 11,6 | 16,0 | 1,5 | 141,0 | 1923 | 384 | 0,5 | 2340 |
| 105 ¹⁾ _{-0,020} | 35 | 32,5 | 160 ⁰ _{-0,025} | 35 ^{+0,25} _{-0,60} | 12,3 | 17,5 | 2,0 | 148,0 | 2116 | 423 | 2,0 | 2930 |
| 110 ¹⁾ _{-0,020} | 38 | 34,0 | 170 ⁰ _{-0,025} | 38 ^{+0,25} _{-0,60} | 13,0 | 19,0 | 2,0 | 155,0 | 2318 | 463 | 3,0 | 3680 |
| 120 ¹⁾ _{-0,020} | 38 | 37,0 | 180 ⁰ _{-0,025} | 38 ^{+0,25} _{-0,60} | 14,5 | 19,0 | 2,0 | 168,0 | 2735 | 547 | 0,5 | 3970 |
| 130 ¹⁾ _{-0,025} | 45 | 43,0 | 200 ⁰ _{-0,030} | 45 ^{+0,35} _{-0,70} | 18,0 | 19,0 | 2,5 | 188,0 | 3550 | 710 | 1,0 | 5920 |
| 140 ¹⁾ _{-0,025} | 45 | 43,0 | 210 ⁰ _{-0,030} | 45 ^{+0,35} _{-0,70} | 19,0 | 19,0 | 2,5 | 198,0 | 3740 | 740 | 1,0 | 6330 |
| 150 ¹⁾ _{-0,025} | 48 | 46,0 | 225 ⁰ _{-0,030} | 48 ^{+0,35} _{-0,70} | 20,0 | 20,5 | 3,0 | 211,0 | 4270 | 850 | 1,0 | 8010 |
| 160 ¹⁾ _{-0,025} | 51 | 49,0 | 240 ⁰ _{-0,030} | 51 ^{+0,35} _{-0,70} | 20,0 | 22,0 | 3,0 | 225,0 | 4850 | 970 | 1,0 | 9790 |
| 170 ¹⁾ _{-0,025} | 57 | 55,0 | 260 ⁰ _{-0,035} | 57 ^{+0,35} _{-0,70} | 21,0 | 27,0 | 3,0 | 246,0 | 5950 | 1190 | 1,0 | 12300 |
| 180 ¹⁾ _{-0,025} | 64 | 61,0 | 280 ⁰ _{-0,035} | 64 ^{+0,35} _{-0,70} | 21,0 | 28,0 | 3,0 | 260,0 | 6970 | 1395 | 1,0 | 17400 |
| 190 ¹⁾ _{-0,030} | 64 | 62,0 | 290 ⁰ _{-0,035} | 64 ^{+0,35} _{-0,80} | 26,0 | 30,0 | 3,0 | 275,0 | 7500 | 1500 | 0,5 | 18200 |
| 200 ¹⁾ _{-0,030} | 70 | 66,0 | 310 ⁰ _{-0,035} | 70 ^{+0,35} _{-0,80} | 26,0 | 30,0 | 3,0 | 290,0 | 8420 | 1680 | 1,5 | 23800 |

Materials:

Housing disk: Bearing steel to 100Cr6, Aisi 52100, hardened, ground, phosphated treated with molybdenum disulphide

Inner disk: Bearing steel to 100Cr6, Aisi 52100, hardened, ground, phosphated treated with molybdenum disulphide

1) Price and availability on request

FLURO®-Gelenklager GmbH

Angular Contact Spherical Plain Bearings - Maintenance Free

Series GE...SW

Angular Contact Spherical Plain Bearings. Mating surface hard chromium/PTFE, maintenance free

For use at uni-directional, dynamic radial and additional axial loads

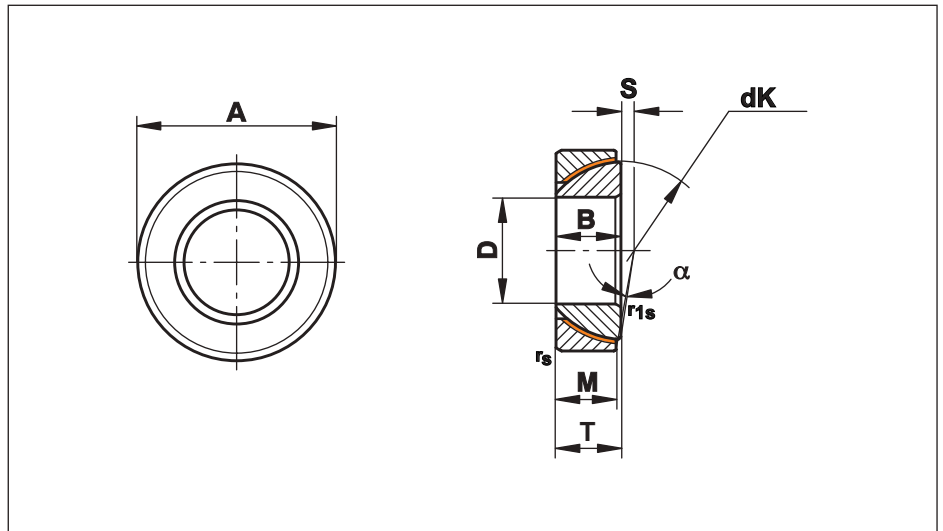

| Size (D) | B | M | A | T | S | rs, r1s min | dk | Radial Load kN | | Maximum Pivoting Angle α (°) | Weight g |
|-------------------------------------|----|------|------------------------------------|--------------------------------------|------|-------------|-------|----------------|-----------|-------------------------------------|----------|
| | | | | | | | | Static Co | Dynamic C | | |
| 25 ⁰ _{-0,012} | 15 | 14,0 | 47 ⁰ _{-0,014} | 15 ^{+0,25} _{-0,40} | 0,6 | 1,0 | 42,0 | 225 | 89 | 2,5 | 148 |
| 28 ⁰ _{-0,012} | 15 | 15,0 | 52 ⁰ _{-0,016} | 16 ^{+0,25} _{-0,40} | 1,0 | 1,0 | 47,0 | 270 | 100 | 2,0 | 186 |
| 30 ⁰ _{-0,012} | 17 | 15,0 | 55 ⁰ _{-0,016} | 17 ^{+0,25} _{-0,40} | 1,3 | 1,0 | 49,5 | 285 | 110 | 4,5 | 208 |
| 32 ⁰ _{-0,012} | 17 | 16,0 | 58 ⁰ _{-0,016} | 17 ^{+0,25} _{-0,40} | 2,0 | 1,0 | 52,0 | 320 | 125 | 2,0 | 241 |
| 35 ⁰ _{-0,012} | 18 | 16,0 | 62 ⁰ _{-0,016} | 18 ^{+0,25} _{-0,40} | 2,1 | 1,0 | 55,5 | 340 | 135 | 4,0 | 268 |
| 40 ⁰ _{-0,012} | 19 | 17,0 | 68 ⁰ _{-0,016} | 19 ^{+0,25} _{-0,40} | 2,8 | 1,0 | 62,0 | 400 | 160 | 3,5 | 327 |
| 45 ⁰ _{-0,012} | 20 | 18,0 | 75 ⁰ _{-0,016} | 20 ^{+0,25} _{-0,40} | 3,5 | 1,0 | 68,5 | 470 | 190 | 3,0 | 416 |
| 50 ⁰ _{-0,012} | 20 | 19,0 | 80 ⁰ _{-0,016} | 20 ^{+0,25} _{-0,40} | 4,3 | 1,0 | 74,0 | 540 | 215 | 1,5 | 455 |
| 55 ⁰ _{-0,015} | 23 | 20,0 | 90 ⁰ _{-0,018} | 23 ^{+0,25} _{-0,50} | 5,0 | 1,1 | 82,0 | 630 | 250 | 4,0 | 645 |
| 60 ⁰ _{-0,015} | 23 | 21,0 | 95 ⁰ _{-0,018} | 23 ^{+0,25} _{-0,50} | 5,7 | 1,1 | 88,5 | 710 | 285 | 2,5 | 714 |
| 65 ⁰ _{-0,015} | 23 | 22,0 | 100 ⁰ _{-0,018} | 23 ^{+0,25} _{-0,50} | 6,5 | 1,1 | 93,5 | 790 | 315 | 1,0 | 759 |
| 70 ⁰ _{-0,015} | 25 | 23,0 | 110 ⁰ _{-0,018} | 25 ^{+0,25} _{-0,50} | 7,2 | 1,1 | 102,0 | 900 | 360 | 2,0 | 1040 |
| 75 ⁰ _{-0,015} | 25 | 24,0 | 115 ⁰ _{-0,018} | 25 ^{+0,25} _{-0,50} | 7,9 | 1,1 | 107,0 | 980 | 395 | 1,0 | 1120 |
| 80 ⁰ _{-0,015} | 29 | 25,5 | 125 ⁰ _{-0,020} | 29 ^{+0,25} _{-0,50} | 8,6 | 1,1 | 115,0 | 1120 | 450 | 3,5 | 1540 |
| 85 ⁰ _{-0,020} | 29 | 26,5 | 130 ⁰ _{-0,020} | 29 ^{+0,25} _{-0,60} | 9,4 | 1,1 | 122,0 | 1240 | 495 | 2,0 | 1610 |
| 90 ⁰ _{-0,020} | 32 | 28,0 | 140 ⁰ _{-0,020} | 32 ^{+0,25} _{-0,60} | 10,1 | 1,5 | 128,5 | 1380 | 550 | 3,5 | 2090 |
| 95 ⁰ _{-0,020} | 32 | 29,5 | 145 ⁰ _{-0,020} | 32 ^{+0,25} _{-0,60} | 10,8 | 1,5 | 135,0 | 1530 | 610 | 2,0 | 2220 |
| 100 ⁰ _{-0,020} | 32 | 31,0 | 150 ⁰ _{-0,020} | 32 ^{+0,25} _{-0,60} | 11,6 | 1,5 | 141,0 | 1680 | 670 | 0,5 | 2340 |
| 105 ¹⁾ _{-0,020} | 35 | 32,5 | 160 ⁰ _{-0,020} | 35 ^{+0,25} _{-0,60} | 12,3 | 2,0 | 148,0 | 1850 | 740 | 2,0 | 2930 |
| 110 ¹⁾ _{-0,020} | 38 | 34,0 | 170 ⁰ _{-0,020} | 38 ^{+0,25} _{-0,60} | 13,0 | 2,0 | 155,0 | 2020 | 810 | 3,0 | 3680 |
| 120 ¹⁾ _{-0,020} | 38 | 37,0 | 180 ⁰ _{-0,025} | 38 ^{+0,25} _{-0,60} | 14,5 | 2,0 | 168,0 | 2390 | 955 | 0,5 | 3970 |
| 130 ¹⁾ _{-0,020} | 45 | 43,0 | 200 ⁰ _{-0,025} | 45 ^{+0,35} _{-0,70} | 18,0 | 2,5 | 188,0 | 3110 | 1240 | 1,0 | 5920 |
| 140 ¹⁾ _{-0,020} | 45 | 43,0 | 210 ⁰ _{-0,025} | 45 ^{+0,35} _{-0,70} | 19,0 | 2,5 | 198,0 | 3270 | 1310 | 1,0 | 6330 |
| 150 ¹⁾ _{-0,025} | 48 | 46,0 | 225 ⁰ _{-0,030} | 48 ^{+0,35} _{-0,70} | 20,0 | 3,0 | 211,0 | 3730 | 1490 | 1,0 | 8010 |
| 160 ¹⁾ _{-0,025} | 51 | 49,0 | 240 ⁰ _{-0,030} | 51 ^{+0,35} _{-0,70} | 20,0 | 3,0 | 225,0 | 4240 | 1690 | 1,0 | 9790 |
| 170 ¹⁾ _{-0,025} | 57 | 55,0 | 260 ⁰ _{-0,035} | 57 ^{+0,35} _{-0,70} | 21,0 | 3,0 | 246,0 | 5200 | 2080 | 1,0 | 12300 |
| 180 ¹⁾ _{-0,025} | 64 | 61,0 | 280 ⁰ _{-0,035} | 64 ^{+0,35} _{-0,70} | 21,0 | 3,0 | 260,0 | 6100 | 2440 | 1,0 | 17400 |
| 190 ¹⁾ _{-0,030} | 64 | 62,0 | 290 ⁰ _{-0,035} | 64 ^{+0,35} _{-0,80} | 26,0 | 3,0 | 275,0 | 6560 | 2620 | 0,5 | 18200 |
| 200 ¹⁾ _{-0,030} | 70 | 66,0 | 310 ⁰ _{-0,035} | 70 ^{+0,35} _{-0,80} | 26,0 | 3,0 | 290,0 | 7360 | 2940 | 1,5 | 23800 |

Materials:

Housing disk: Bearing steel to 100Cr6, Aisi 52100, hardened with PTFE liner bonded to the inner surface

Inner disk: Bearing steel to 100Cr6, Aisi 52100, hardened, ground, polished, hard chrome plated

On request: Stainless steel version

1) Price and availability on request

Spherical Plain Thrust Bearings - Steel on Steel

Series GE...AX

Spherical Plain Thrust Bearings steel on steel.
Treated with molybdenum disulphide mos2, regreasable

For use at axial loads

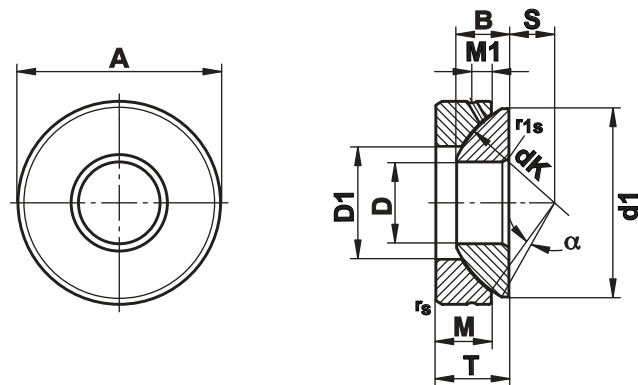

| Size (D) | B | M | A | T | S | M1 | r _s , r _{1s} min | d ₁ max | D ₁ min | d _k | Axiale load kN | | Maximum Pivoting Angle α (°) | Weight g |
|-------------------------------------|------|------|------------------------------------|--|------|------|--------------------------------------|--------------------|--------------------|----------------|-----------------------|-----------|------------------------------|----------|
| | | | | | | | | | | | Static C ₀ | Dynamic C | | |
| 10 ⁰ _{-0,008} | 7,5 | 7,0 | 30 ⁰ _{-0,009} | 9,5 ^{+0,25} _{-0,40} | 7,0 | 3,0 | 0,6 | 27,5 | 15,5 | 32 | 136 | 27 | 5 | 36 |
| 12 ⁰ _{-0,008} | 9,5 | 9,3 | 35 ⁰ _{-0,011} | 13,0 ^{+0,25} _{-0,40} | 8,0 | 4,0 | 0,6 | 32,0 | 18,0 | 38 | 188 | 37 | 5 | 72 |
| 15 ⁰ _{-0,008} | 11,0 | 10,8 | 42 ⁰ _{-0,011} | 15,0 ^{+0,25} _{-0,40} | 10,0 | 5,0 | 0,6 | 39,0 | 22,5 | 46 | 267 | 53 | 6 | 108 |
| 17 ⁰ _{-0,008} | 11,8 | 11,2 | 47 ⁰ _{-0,011} | 16,0 ^{+0,25} _{-0,40} | 11,0 | 5,0 | 0,6 | 43,5 | 27,0 | 52 | 311 | 61 | 4 | 137 |
| 20 ⁰ _{-0,010} | 14,5 | 13,8 | 55 ⁰ _{-0,013} | 20,0 ^{+0,25} _{-0,40} | 12,5 | 6,0 | 1,0 | 50,0 | 31,0 | 60 | 425 | 84 | 5 | 246 |
| 25 ⁰ _{-0,010} | 16,5 | 16,7 | 62 ⁰ _{-0,013} | 22,5 ^{+0,25} _{-0,40} | 14,0 | 6,0 | 1,0 | 58,5 | 34,5 | 68 | 672 | 134 | 5 | 415 |
| 30 ⁰ _{-0,010} | 19,0 | 19,0 | 75 ⁰ _{-0,013} | 26,0 ^{+0,25} _{-0,40} | 17,5 | 8,0 | 1,0 | 70,0 | 42,0 | 82 | 909 | 182 | 5 | 614 |
| 35 ⁰ _{-0,012} | 22,0 | 20,7 | 90 ⁰ _{-0,015} | 28,0 ^{+0,25} _{-0,40} | 22,0 | 8,0 | 1,0 | 84,0 | 50,5 | 98 | 1330 | 266 | 5 | 973 |
| 40 ⁰ _{-0,012} | 27,0 | 21,5 | 105 ⁰ _{-0,015} | 32,0 ^{+0,25} _{-0,40} | 24,5 | 9,0 | 1,0 | 97,0 | 59,0 | 114 | 1810 | 357 | 6 | 1590 |
| 45 ⁰ _{-0,012} | 31,0 | 25,5 | 120 ⁰ _{-0,015} | 36,5 ^{+0,25} _{-0,40} | 27,5 | 11,0 | 1,0 | 110,0 | 67,0 | 128 | 2470 | 486 | 6 | 2240 |
| 50 ⁰ _{-0,012} | 33,0 | 30,5 | 130 ⁰ _{-0,018} | 42,5 ^{+0,25} _{-0,40} | 30,0 | 10,0 | 1,0 | 120,0 | 70,0 | 139 | 2810 | 554 | 6 | 3140 |
| 60 ⁰ _{-0,015} | 37,0 | 34,0 | 150 ⁰ _{-0,018} | 45,0 ^{+0,25} _{-0,50} | 35,0 | 12,5 | 1,0 | 140,0 | 84,0 | 160 | 3820 | 748 | 6 | 4630 |
| 70 ⁰ _{-0,015} | 42,0 | 36,5 | 160 ⁰ _{-0,025} | 50,0 ^{+0,25} _{-0,50} | 35,0 | 13,5 | 1,0 | 153,0 | 94,5 | 176 | 4610 | 902 | 3 | 5370 |
| 80 ⁰ _{-0,015} | 43,5 | 38,0 | 180 ⁰ _{-0,025} | 50,0 ^{+0,25} _{-0,50} | 42,5 | 14,5 | 1,0 | 172,0 | 107,5 | 197 | 5700 | 1110 | 4 | 6910 |
| 100 ⁰ _{-0,020} | 51,0 | 46,0 | 210 ⁰ _{-0,030} | 59,0 ^{+0,25} _{-0,60} | 45,0 | 15,0 | 1,1 | 198,0 | 127,0 | 222 | 6470 | 1300 | 4 | 11000 |
| 120 ¹⁾ _{-0,020} | 53,5 | 50,0 | 230 ⁰ _{-0,030} | 64,0 ^{+0,25} _{-0,60} | 52,5 | 16,5 | 1,1 | 220,0 | 145,0 | 250 | 7580 | 1530 | 3 | 14000 |
| 140 ¹⁾ _{-0,025} | 61,0 | 54,0 | 260 ⁰ _{-0,035} | 72,0 ^{+0,35} _{-0,70} | 52,5 | 23,0 | 1,5 | 243,0 | 177,0 | 274 | 9040 | 1820 | 3 | 19100 |
| 160 ¹⁾ _{-0,025} | 66,0 | 58,0 | 290 ⁰ _{-0,035} | 77,0 ^{+0,35} _{-0,70} | 65,0 | 23,0 | 1,5 | 271,0 | 200,0 | 313 | 10440 | 2100 | 2 | 25000 |
| 180 ¹⁾ _{-0,025} | 74,0 | 62,0 | 320 ⁰ _{-0,040} | 86,0 ^{+0,35} _{-0,70} | 67,5 | 26,0 | 1,5 | 299,0 | 225,0 | 340 | 12070 | 2430 | 4 | 32800 |
| 200 ¹⁾ _{-0,030} | 80,0 | 66,0 | 340 ⁰ _{-0,045} | 87,0 ^{+0,35} _{-0,80} | 70,0 | 27,0 | 1,5 | 320,0 | 247,0 | 365 | 15280 | 3070 | 1 | 35400 |

Materials:

Housing disk: Bearing steel to 100Cr6, Aisi 52100, hardened, ground, phosphated treated with molybdenum disulphide

Inner disk: Bearing steel to 100Cr6, Aisi 52100, hardened, ground, phosphated treated with molybdenum disulphide

¹⁾ Price and availability on request

Spherical Plain Thrust Bearings - Maintenance Free

Series GE...AW

Spherical Plain Thrust Bearings.
Mating surface hard chromium/PTFE, maintenance free

For use with axial loads

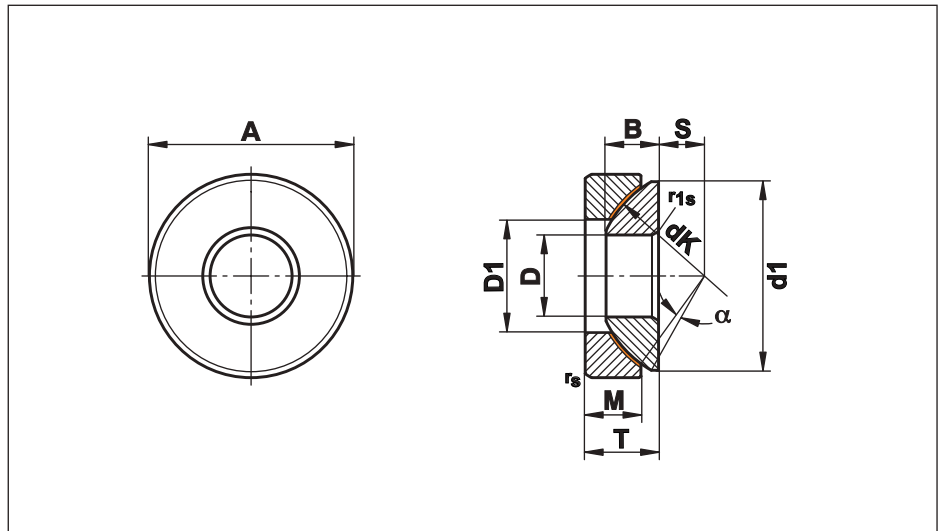

| Size (D) | B | M | A | T | S | r _s , r _{1s} min | d ₁ max | D ₁ min | d _k | Axiale load kN | | Maximum Pivoting Angle α (°) | Weight g |
|-------------------|-------|------|-----|-------|------|--------------------------------------|--------------------|--------------------|----------------|-----------------------|-----------|------------------------------|----------|
| | | | | | | | | | | Static C ₀ | Dynamic C | | |
| 10 | 7,5 | 7,0 | 30 | 9,5 | 7,0 | 0,6 | 27,5 | 15,5 | 32 | 120 | 45 | 5,0 | 36 |
| 12 | 9,5 | 9,3 | 35 | 13,0 | 8,0 | 0,6 | 32,0 | 18,0 | 38 | 165 | 65 | 5,0 | 72 |
| 15 | 11,0 | 10,8 | 42 | 15,0 | 10,0 | 0,6 | 39,0 | 22,5 | 46 | 235 | 95 | 6,0 | 108 |
| 17 | 11,8 | 11,2 | 47 | 16,0 | 11,0 | 0,6 | 43,5 | 27,0 | 52 | 275 | 110 | 4,0 | 137 |
| 20 | 14,5 | 13,8 | 55 | 20,0 | 12,5 | 1,0 | 50,0 | 31,0 | 60 | 380 | 150 | 5,0 | 246 |
| 25 | 16,5 | 16,7 | 62 | 22,5 | 14,0 | 1,0 | 58,5 | 34,5 | 68 | 600 | 245 | 5,0 | 415 |
| 30 | 19,0 | 19,0 | 75 | 26,0 | 17,5 | 1,0 | 70,0 | 42,0 | 82 | 820 | 335 | 5,0 | 614 |
| 35 | 22,0 | 20,7 | 90 | 28,0 | 22,0 | 1,0 | 84,0 | 50,5 | 98 | 1200 | 490 | 5,0 | 973 |
| 40 | 27,0 | 21,5 | 105 | 32,0 | 24,5 | 1,0 | 97,0 | 59,0 | 114 | 1640 | 675 | 6,0 | 1590 |
| 45 | 31,0 | 25,5 | 120 | 36,5 | 27,5 | 1,0 | 110,0 | 67,0 | 128 | 2240 | 915 | 6,0 | 2240 |
| 50 | 33,0 | 30,5 | 130 | 42,5 | 30,0 | 1,0 | 120,0 | 70,0 | 139 | 2550 | 1040 | 6,0 | 3140 |
| 60 | 37,0 | 34,0 | 150 | 45,0 | 35,0 | 1,0 | 140,0 | 84,0 | 160 | 3470 | 1360 | 6,0 | 4630 |
| 70 | 42,0 | 36,5 | 160 | 50,0 | 35,0 | 1,0 | 153,0 | 94,5 | 176 | 4180 | 1640 | 3,0 | 5370 |
| 80 | 43,5 | 38,0 | 180 | 50,0 | 42,5 | 1,0 | 172,0 | 107,5 | 197 | 5180 | 2030 | 4,0 | 6910 |
| 100 | 51,0 | 46,0 | 210 | 59,0 | 45,0 | 1,1 | 198,0 | 127,0 | 222 | 5940 | 2230 | 4,0 | 11000 |
| 120 ¹⁾ | 53,5 | 50,0 | 230 | 64,0 | 52,5 | 1,1 | 220,0 | 145,0 | 250 | 6960 | 2610 | 3,0 | 14000 |
| 140 ¹⁾ | 61,0 | 54,0 | 260 | 72,0 | 52,5 | 1,5 | 243,0 | 177,0 | 274 | 8300 | 3120 | 3,0 | 19100 |
| 160 ¹⁾ | 66,0 | 58,0 | 290 | 77,0 | 65,0 | 1,5 | 271,0 | 200,0 | 313 | 9560 | 3380 | 2,0 | 25000 |
| 180 ¹⁾ | 74,0 | 62,0 | 320 | 86,0 | 67,5 | 1,5 | 299,0 | 225,0 | 340 | 11050 | 3910 | 4,0 | 32800 |
| 200 ¹⁾ | 80,0 | 66,0 | 340 | 87,0 | 70,0 | 1,5 | 320,0 | 247,0 | 365 | 13990 | 4950 | 1,0 | 35400 |
| 220 ¹⁾ | 82,0 | 67,0 | 370 | 97,0 | 75,0 | 1,5 | 350,0 | 265,5 | 388 | 13110 | 4640 | 7,0 | 44700 |
| 240 ¹⁾ | 87,0 | 73,0 | 400 | 103,0 | 77,5 | 1,5 | 382,0 | 294,0 | 420 | 15560 | 5500 | 6,0 | 56900 |
| 260 ¹⁾ | 95,0 | 80,0 | 430 | 115,0 | 82,5 | 1,5 | 409,0 | 317,0 | 449 | 17510 | 6190 | 7,0 | 71300 |
| 280 ¹⁾ | 100,0 | 85,0 | 460 | 110,0 | 80,0 | 3,0 | 445,0 | 337,0 | 480 | 23400 | 8280 | 4,0 | 84700 |
| 300 ¹⁾ | 100,0 | 90,0 | 480 | 110,0 | 80,0 | 3,0 | 460,0 | 356,0 | 490 | 25480 | 9010 | 3,5 | 88900 |
| 320 ¹⁾ | 105,0 | 91,0 | 520 | 116,0 | 95,0 | 4,0 | 500,0 | 380,0 | 540 | 33260 | 11360 | 4,0 | 111000 |
| 340 ¹⁾ | 105,0 | 91,0 | 540 | 116,0 | 95,0 | 4,0 | 510,0 | 380,0 | 550 | 33880 | 11570 | 4,0 | 117000 |
| 360 ¹⁾ | 115,0 | 95,0 | 560 | 125,0 | 95,0 | 4,0 | 535,0 | 400,0 | 575 | 37630 | 12850 | 4,0 | 132000 |

Materials:

Housing disk: Bearing steel to 100Cr6, Aisi 52100, hardened with PTFE liner bonded to the inner surface

Inner disk: Bearing steel to 100Cr6, Aisi 52100, hardened, ground, polished, hard chrome plated

On request: Stainless steel version

¹⁾ Price and availability on request

Hydraulic Rod Ends to DIN 24555 / ISO 8133

Series FPR...S

Rod Ends, fastened by hexagon socket head cap screw to DIN 912-8.8.
Spherical Plain Bearings, regreasable, fixed through caulking on both sides

For use in standard Hydraulic Cylinders 160 bar to ISO 6020/2

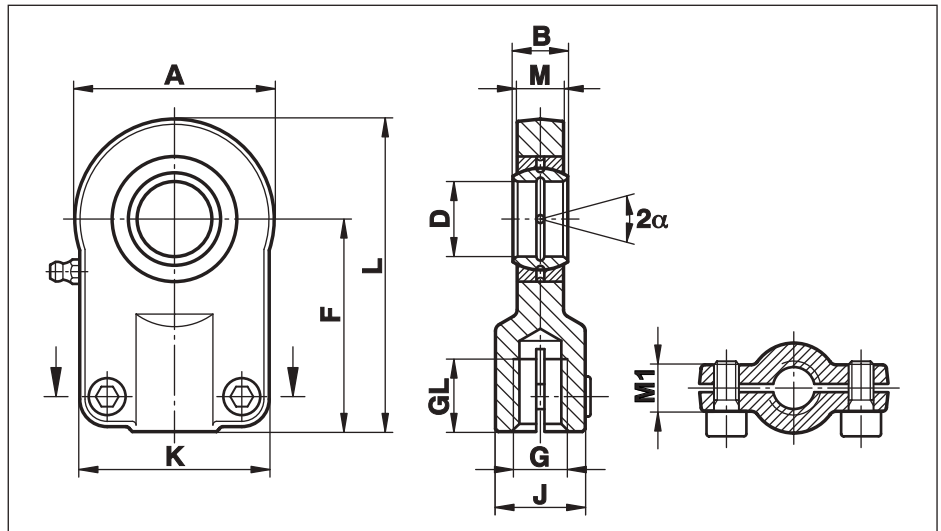

| Size (D) | B | M | M1 | A | F | L | K | J | G | GL | Torque Nm | Static load C ₀ kN | Dynamic load C kN | Maximum Pivoting Angle α (°) | Weight g |
|----------|----|----|----|-----|-----|-------|-----|-----|-----------|----|-----------|-------------------------------|-------------------|------------------------------|----------|
| 12 | 10 | 8 | 13 | 35 | 42 | 58,0 | 40 | 17 | M 10x1,25 | 15 | 10 | 17,0 | 10,8 | 11 | 120 |
| 16 | 14 | 11 | 13 | 45 | 48 | 69,0 | 45 | 21 | M 12x1,25 | 17 | 10 | 28,5 | 21,1 | 10 | 220 |
| 20 | 16 | 13 | 17 | 55 | 58 | 83,0 | 55 | 25 | M 14x1,5 | 19 | 25 | 42,5 | 30,0 | 9 | 430 |
| 25 | 20 | 17 | 17 | 65 | 68 | 99,0 | 62 | 30 | M 16x1,5 | 23 | 25 | 67,0 | 48,0 | 7 | 670 |
| 30 | 22 | 19 | 19 | 80 | 85 | 123,0 | 77 | 36 | M 20x1,5 | 29 | 49 | 108,0 | 62,0 | 6 | 1250 |
| 40 | 28 | 23 | 23 | 100 | 105 | 153,0 | 90 | 45 | M 27x2 | 37 | 49 | 156,0 | 100,0 | 7 | 2160 |
| 50 | 35 | 30 | 30 | 120 | 130 | 188,0 | 105 | 55 | M 33x2 | 46 | 86 | 245,0 | 156,0 | 6 | 3900 |
| 60 | 44 | 38 | 38 | 160 | 150 | 230,0 | 134 | 68 | M 42x2 | 57 | 210 | 380,0 | 245,0 | 6 | 7150 |
| 80 | 55 | 47 | 47 | 205 | 185 | 282,5 | 156 | 90 | M 48x2 | 64 | 410 | 585,0 | 400,0 | 6 | 15000 |
| 100 | 70 | 55 | 55 | 240 | 240 | 357,5 | 190 | 110 | M 64x3 | 86 | 710 | 865,0 | 610,0 | 7 | 27300 |

Materials:

Housing: up to size 50 forged from heat-treated steel to C45, Aisi 1045
from size 60 made from nodular cast iron GS 400

Bearing: Steel on steel bearing GE...E, requiring lubrication

Greasing: Size 12 is not regreasable über Schmiernippel
from size 16 - 20 fitted with grease hole in housing
from size 25 fitted with hydraulic grease nipples to DIN 71412

On request: with left hand thread (FPL...S)

Hydraulic Rod Ends to DIN 24338 / ISO 6982

Series FPR...CE

Rod Ends Cetop, recommendation RP 58H for standard Hydraulic Cylinders, fastened by hexagon socket head cap screws to DIN 912-8.8. Spherical Plain Bearings, regreasable, fixed with snap rings

Mounting dimensions to DIN 24333-24336 and ISO 6020/1, ISO 6022

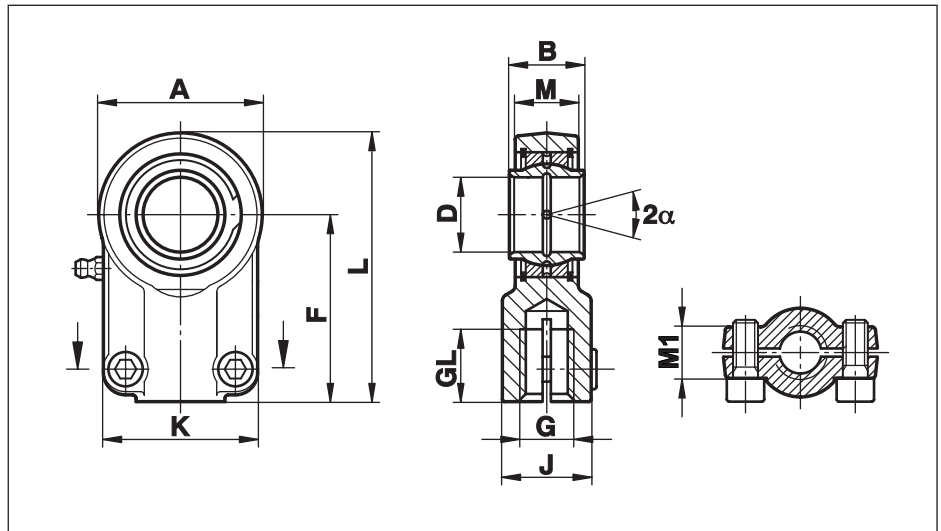

| Size (D) | B | M | M1 | A | F | L | K | J | G | GL | Torque Nm | Static load C ₀ kN | Dynamic load C kN | Maximum Pivoting Angle α (°) | Weight g |
|----------|-----|-------|-------|-------|-----|-------|-----|-----|-----------|-----|-----------|-------------------------------|-------------------|------------------------------|----------|
| 12 | 12 | 11,0 | 15,0 | 32,0 | 38 | 54,0 | 32 | 16 | M 12x1,25 | 17 | 6 | 24,5 | 10,8 | 4 | 110 |
| 16 | 16 | 13,0 | 15,0 | 40,0 | 44 | 64,0 | 40 | 21 | M 14x1,5 | 19 | 10 | 36,5 | 17,6 | 4 | 200 |
| 20 | 20 | 17,0 | 19,0 | 47,0 | 52 | 77,0 | 47 | 25 | M 16x1,5 | 23 | 25 | 48,0 | 30,0 | 4 | 350 |
| 25 | 25 | 22,0 | 19,0 | 58,0 | 65 | 96,0 | 54 | 30 | M 20x1,5 | 29 | 25 | 78,0 | 48,0 | 4 | 620 |
| 32 | 32 | 28,0 | 22,0 | 71,0 | 80 | 118,0 | 66 | 38 | M 27x2 | 37 | 49 | 114,0 | 67,0 | 4 | 1150 |
| 40 | 40 | 33,0 | 26,0 | 90,0 | 97 | 146,0 | 80 | 47 | M 33x2 | 46 | 49 | 204,0 | 100,0 | 4 | 2180 |
| 50 | 50 | 41,0 | 32,0 | 109,0 | 120 | 179,0 | 96 | 58 | M 42x2 | 57 | 86 | 310,0 | 156,0 | 4 | 3960 |
| 63 | 63 | 53,0 | 38,0 | 136,0 | 140 | 213,0 | 114 | 70 | M 48x2 | 64 | 210 | 430,0 | 255,0 | 4 | 6800 |
| 70 | 70 | 57,0 | 42,0 | 155,0 | 160 | 245,0 | 135 | 80 | M 56x2 | 76 | 210 | 540,0 | 315,0 | 4 | 9600 |
| 80 | 80 | 67,0 | 48,0 | 170,0 | 180 | 270,0 | 148 | 90 | M 64x3 | 86 | 410 | 695,0 | 400,0 | 4 | 13000 |
| 90 | 90 | 72,0 | 52,0 | 185,0 | 195 | 296,0 | 160 | 100 | M 72x3 | 91 | 410 | 750,0 | 490,0 | 4 | 19100 |
| 100 | 100 | 85,0 | 62,0 | 211,0 | 210 | 322,0 | 178 | 110 | M 80x3 | 96 | 710 | 1060,0 | 610,0 | 4 | 25000 |
| 110 | 110 | 88,0 | 62,0 | 235,0 | 235 | 364,0 | 190 | 125 | M 90x3 | 106 | 710 | 1200,0 | 655,0 | 4 | 32000 |
| 125 | 125 | 103,0 | 72,0 | 265,0 | 260 | 406,5 | 200 | 135 | M 100x3 | 113 | 710 | 1430,0 | 950,0 | 4 | 46000 |
| 160 | 160 | 130,0 | 82,0 | 326,0 | 310 | 488,0 | 250 | 165 | M 125x4 | 126 | 710 | 2200,0 | 1370,0 | 4 | 82500 |
| 200 | 200 | 162,0 | 102,0 | 418,0 | 390 | 620,0 | 320 | 215 | M 160x4 | 161 | 1500 | 3650,0 | 2120,0 | 4 | 168000 |

Materials:

Housing: up to size 63 forged from heat-treated steel to C45, Aisi 1045
from size 70 made from nodular cast iron GS 400

Bearing: Steel on steel bearing GE..LO (see page 82)

Greasing: size 12 is not regreasable über Schmiernippel
from size 16 fitted with hydraulic grease nipples to DIN 71412

On request: with left hand thread (FPL...CE)

Hydraulic Rod Ends

Series FPR...N

Rod Ends with short thread, particular suited for Hydraulic Cylinders. Spherical Plain Bearings, regreasable, fixed with snap rings

For use with shortest relay distances and maximum stroke utilization

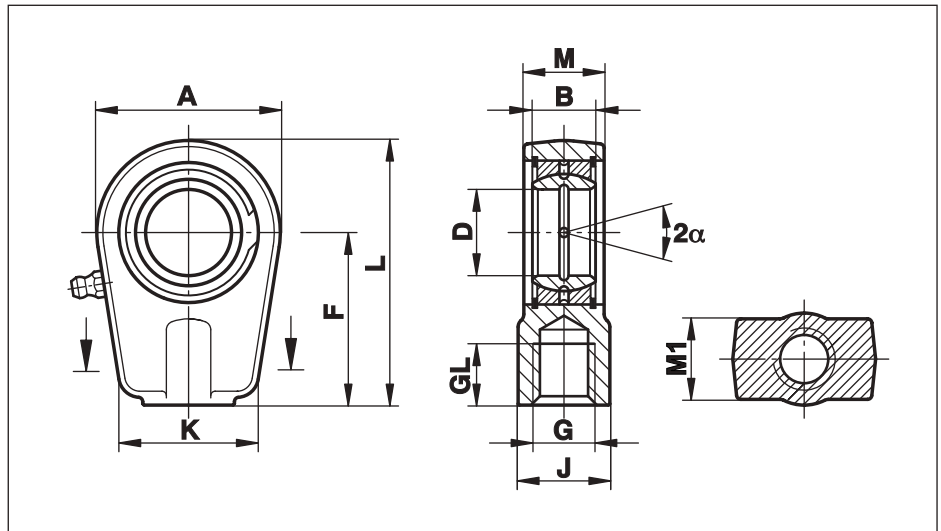

| Size (D) | B | M | M1 | A | F | L | K | J | G | GL | Static load C ₀ kN | Dynamic load C kN | Maximum Pivoting Angle α (°) | Weight g |
|----------|----|----|----|-----|-----|-------|-----|-----|----------|-----|-------------------------------|-------------------|------------------------------|----------|
| 20 | 16 | 19 | 17 | 56 | 50 | 80,0 | 46 | 25 | M 16x1,5 | 17 | 81,1 | 30 | 9 | 450 |
| 25 | 20 | 23 | 21 | 56 | 50 | 80,0 | 46 | 25 | M 16x1,5 | 17 | 72,0 | 48 | 7 | 490 |
| 30 | 22 | 28 | 26 | 64 | 60 | 94,0 | 50 | 32 | M 22x1,5 | 23 | 106,0 | 62 | 6 | 760 |
| 35 | 25 | 30 | 28 | 78 | 70 | 112,0 | 66 | 40 | M 28x1,5 | 29 | 153,0 | 80 | 6 | 1260 |
| 40 | 28 | 35 | 33 | 94 | 85 | 135,0 | 76 | 49 | M 35x1,5 | 36 | 250,0 | 100 | 7 | 2150 |
| 50 | 35 | 40 | 37 | 116 | 105 | 168,0 | 90 | 61 | M 45x1,5 | 46 | 365,0 | 156 | 6 | 3800 |
| 60 | 44 | 50 | 46 | 130 | 130 | 200,0 | 120 | 75 | M 58x1,5 | 59 | 400,0 | 245 | 6 | 6200 |
| 70 | 49 | 55 | 51 | 154 | 150 | 232,0 | 130 | 86 | M 65x1,5 | 66 | 540,0 | 315 | 6 | 9830 |
| 80 | 55 | 60 | 55 | 176 | 170 | 265,0 | 160 | 105 | M 80x2 | 81 | 670,0 | 400 | 6 | 13970 |
| 90 | 60 | 65 | 60 | 206 | 210 | 322,0 | 180 | 124 | M 100x2 | 101 | 980,0 | 490 | 5 | 23500 |
| 100 | 70 | 70 | 65 | 231 | 235 | 360,0 | 200 | 138 | M 110x2 | 111 | 1120,0 | 610 | 7 | 32000 |
| 110 | 70 | 80 | 74 | 266 | 265 | 407,0 | 220 | 152 | M 120x3 | 125 | 1700,0 | 655 | 6 | 41000 |
| 120 | 85 | 90 | 84 | 340 | 310 | 490,0 | 257 | 172 | M 130x3 | 135 | 2900,0 | 950 | 6 | 72000 |

Materials:

Housing: up to size 80 forged from heat-treated steel to C45, Aisi 1045
from size 90 made from nodular cast iron GS 400

Bearing: Steel on steel bearing GE...E, requiring maintenance (see page 78)

Greasing: fitted with hydraulic grease nipples to DIN 71412

On request: with left hand thread (FPL...N)

Hydraulic Rod Ends

Series FPR...U

Rod Ends identical with FPR...N, in addition fastened by hexagon socket head cap screws to DIN 912-8.8. Spherical Plain Bearings, regreasable, fixed with snap rings

For use with shortest relay distances and maximum stroke utilization

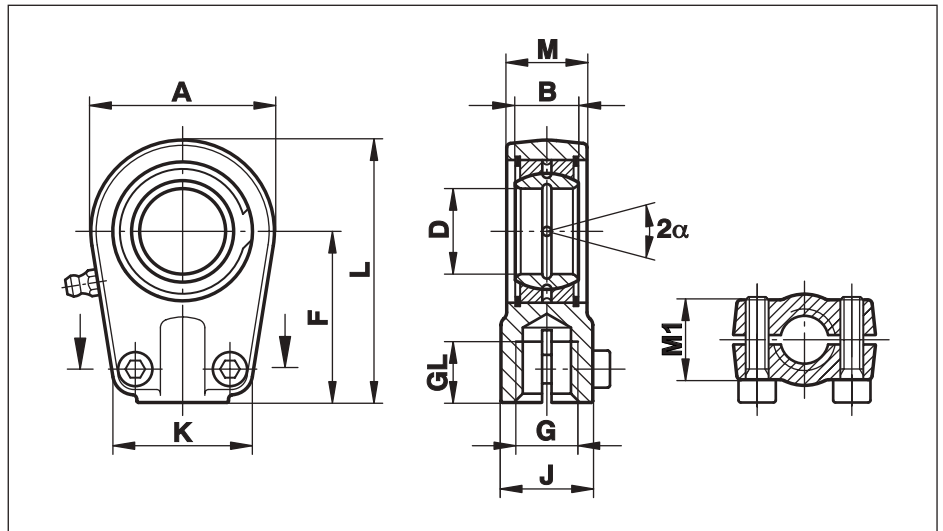

| Size (D) | B | M | M1 | A | F | L | K | J | G | GL | Torque Nm | Static load C ₀ kN | Dynamic load C kN | Maximum Pivoting Angle α (°) | Weight g |
|----------|----|----|----|-----|-----|-------|-----|-----|----------|-----|-----------|-------------------------------|-------------------|------------------------------|----------|
| 20 | 16 | 19 | 17 | 56 | 50 | 80,0 | 46 | 25 | M 16x1,5 | 17 | 25 | 81,1 | 30 | 9 | 440 |
| 25 | 20 | 23 | 21 | 56 | 50 | 80,0 | 46 | 25 | M 16x1,5 | 17 | 25 | 72,0 | 48 | 7 | 470 |
| 30 | 22 | 28 | 26 | 64 | 60 | 94,0 | 50 | 32 | M 22x1,5 | 23 | 25 | 106,0 | 62 | 6 | 770 |
| 35 | 25 | 30 | 28 | 78 | 70 | 112,0 | 66 | 40 | M 28x1,5 | 29 | 49 | 153,0 | 80 | 6 | 1240 |
| 40 | 28 | 35 | 33 | 94 | 85 | 135,0 | 76 | 49 | M 35x1,5 | 36 | 49 | 250,0 | 100 | 7 | 2120 |
| 50 | 35 | 40 | 37 | 116 | 105 | 168,0 | 90 | 61 | M 45x1,5 | 46 | 86 | 365,0 | 156 | 6 | 3740 |
| 60 | 44 | 50 | 46 | 130 | 130 | 200,0 | 120 | 75 | M 58x1,5 | 59 | 210 | 400,0 | 245 | 6 | 6490 |
| 70 | 49 | 55 | 51 | 154 | 150 | 232,0 | 130 | 86 | M 65x1,5 | 66 | 210 | 540,0 | 315 | 6 | 9880 |
| 80 | 55 | 60 | 55 | 176 | 170 | 265,0 | 160 | 105 | M 80x2 | 81 | 410 | 670,0 | 400 | 6 | 14200 |
| 90 | 60 | 65 | 60 | 206 | 210 | 322,0 | 180 | 124 | M 100x2 | 101 | 410 | 980,0 | 490 | 5 | 20000 |
| 100 | 70 | 70 | 65 | 231 | 235 | 360,0 | 200 | 138 | M 110x2 | 111 | 710 | 1120,0 | 610 | 7 | 27500 |
| 110 | 70 | 80 | 74 | 266 | 265 | 407,5 | 220 | 152 | M 120x3 | 125 | 710 | 1700,0 | 655 | 6 | 45600 |
| 120 | 85 | 90 | 84 | 340 | 310 | 490,0 | 257 | 172 | M 130x3 | 135 | 710 | 2900,0 | 950 | 6 | 72000 |

Materials:

Housing: up to size 80 forged from heat-treated steel to C45, Aisi 1045
from size 90 made from nodular cast iron GS 400

Bearing: Steel on steel bearing GE...E, requiring maintenance (see page 78)
On request also available with Spherical Plain Bearing GE...LO (see page 82)

Greasing: fitted with hydraulic grease nipples to DIN 71412

On request: with left hand thread (FPL...U)

Hydraulic Rod Ends

Series FMA...D

Rod Ends fastened by hexagon socket head cap screws to DIN 912-8.8. Spherical Plain Bearings, regreasable, fixed with snap rings

For use with double action Hydraulic Cylinders

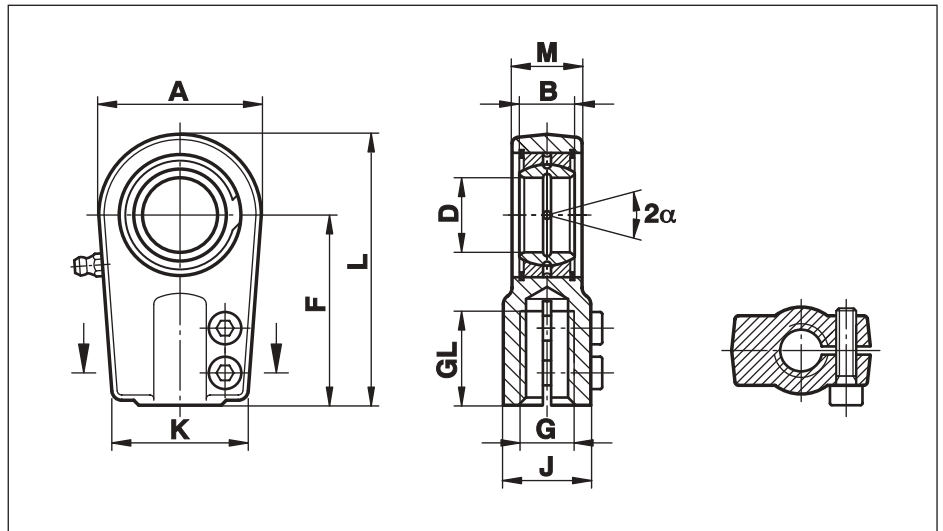

| Size (D) | B | M | A | F | L | K | J | G | GL | Torque Nm | Static load C ₀ kN | Dynamic load C kN | Maximum Pivoting Angle α (°) | Weight g |
|----------|-----|-----|-----|-----|-----|-----|-----|---------|-----|-----------|-------------------------------|-------------------|------------------------------|----------|
| 25 | 20 | 23 | 56 | 65 | 95 | 48 | 28 | M 18x2 | 30 | 20 | 76 | 48 | 8 | 650 |
| 30 | 22 | 28 | 64 | 75 | 109 | 56 | 34 | M 24x2 | 35 | 20 | 112 | 62 | 7 | 1000 |
| 35 | 25 | 30 | 78 | 90 | 132 | 70 | 44 | M 30x2 | 45 | 40 | 180 | 80 | 7 | 1300 |
| 40 | 28 | 35 | 94 | 105 | 155 | 78 | 55 | M 39x3 | 55 | 80 | 295 | 100 | 7 | 2400 |
| 50 | 35 | 40 | 116 | 135 | 198 | 88 | 70 | M 50x3 | 75 | 80 | 445 | 156 | 7 | 4100 |
| 60 | 44 | 50 | 130 | 170 | 240 | 118 | 87 | M 64x3 | 95 | 160 | 530 | 245 | 7 | 6500 |
| 70 | 49 | 55 | 154 | 195 | 278 | 138 | 105 | M 80x3 | 110 | 160 | 720 | 315 | 6 | 9500 |
| 80 | 55 | 60 | 176 | 210 | 305 | 168 | 125 | M 90x3 | 120 | 300 | 890 | 400 | 6 | 16000 |
| 90 | 60 | 65 | 206 | 250 | 363 | 180 | 150 | M 100x3 | 140 | 300 | 1300 | 490 | 5 | 28000 |
| 100 | 70 | 70 | 230 | 275 | 400 | 188 | 170 | M 110x4 | 150 | 300 | 1490 | 610 | 7 | 34000 |
| 110 | 70 | 80 | 264 | 300 | 442 | 210 | 180 | M 120x4 | 160 | 500 | 2050 | 650 | 6 | 44000 |
| 120 | 85 | 90 | 340 | 360 | 540 | 240 | 210 | M 150x4 | 190 | 500 | 2970 | 950 | 6 | 75000 |
| 140 | 90 | 110 | 380 | 420 | 620 | 256 | 230 | M 160x4 | 210 | 1100 | 3350 | 1080 | 7 | 160000 |
| 160 | 105 | 110 | 480 | 460 | 710 | 290 | 260 | M 180x4 | 230 | 1100 | 4300 | 1370 | 8 | 185000 |

Materials:

Housing: Nodular cast iron GS400

Bearing: Steel on steel bearing GE...E, requiring lubrication

Greasing: size 25 without lubrication fitting, but fitted with grease hole in housing from size 30 fitted with hydraulic grease nipples to DIN 71412

On request: with left hand thread (FMAL...D)

Hydraulic Rod Ends - Weld-On Base

Series FS...C

Rod Ends series E to DIN ISO 12240-4, type S with circular surface for weld-on. Spherical Plain Bearings, regreasable, fixed through caulking on both sides

For Weld-on to piston Rod Ends

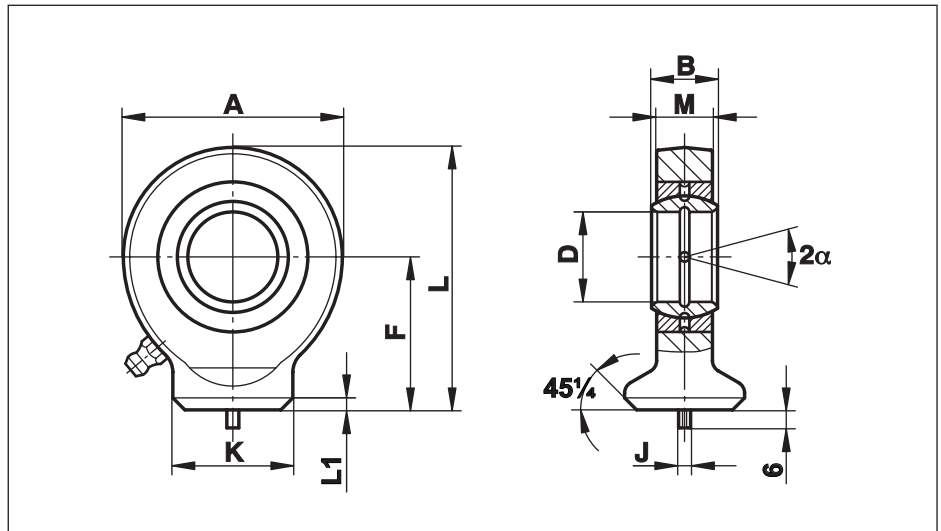

| Size (D) | B | M | A | F | L | L1 | K | J | Static load C ₀ kN | Dynamic load C kN | Maximum Pivoting Angle α (°) | Weight g |
|----------|----|----|-----|-----|-------|-----|------|---|-------------------------------|-------------------|------------------------------|----------|
| 10 | 9 | 7 | 29 | 24 | 38,5 | 1,5 | 15,0 | 3 | 15,6 | 8,15 | 12 | 40 |
| 12 | 10 | 8 | 34 | 27 | 44,0 | 1,5 | 17,5 | 3 | 21,6 | 10,80 | 11 | 60 |
| 15 | 12 | 10 | 40 | 31 | 51,0 | 2,0 | 21,0 | 4 | 32,0 | 17,00 | 8 | 120 |
| 17 | 14 | 11 | 46 | 35 | 58,0 | 2,0 | 24,0 | 4 | 40,0 | 21,20 | 10 | 180 |
| 20 | 16 | 13 | 53 | 38 | 64,5 | 2,0 | 27,5 | 4 | 54,0 | 30,00 | 9 | 260 |
| 25 | 20 | 17 | 64 | 45 | 77,0 | 3,0 | 33,5 | 4 | 72,0 | 48,00 | 7 | 450 |
| 30 | 22 | 19 | 73 | 51 | 87,5 | 3,0 | 40,0 | 4 | 95,0 | 62,00 | 6 | 670 |
| 35 | 25 | 21 | 82 | 61 | 102,0 | 3,0 | 47,0 | 4 | 125,0 | 80,00 | 6 | 1020 |
| 40 | 28 | 23 | 92 | 69 | 115,0 | 4,0 | 52,0 | 4 | 156,0 | 100,00 | 7 | 1400 |
| 45 | 32 | 27 | 102 | 77 | 128,0 | 4,0 | 58,0 | 6 | 208,0 | 127,00 | 7 | 1930 |
| 50 | 35 | 30 | 112 | 88 | 144,0 | 4,0 | 62,0 | 6 | 250,0 | 156,00 | 6 | 2690 |
| 60 | 44 | 38 | 135 | 100 | 167,5 | 4,0 | 70,0 | 6 | 390,0 | 245,00 | 6 | 4600 |
| 70 | 49 | 42 | 160 | 115 | 195,0 | 5,0 | 80,0 | 6 | 510,0 | 315,00 | 6 | 7000 |
| 80 | 55 | 47 | 180 | 141 | 231,0 | 5,0 | 95,0 | 6 | 620,0 | 400,00 | 6 | 11000 |

Materials:

Housing: St 52-3, forged

Bearing: Steel on steel bearing GE...E, requiring maintenance (see page 78)
On request: available with maintenance free Spherical Plain Bearing GE..EC (see page 70) or in sizes 12, 20, 25, 40, 50, 70, 80, with Spherical Plain Bearing GE...LO (see page 82), requiring maintenance

Greasing: up to size 12 without lubrication fitting
 from size 15 - 20 fitted with grease hole in housing
 from size 25 fitted with hydraulic grease nipples to DIN 71412

On request: **Housing:** Stainless steel to 1.4401
 from size 10 to 80 available with maintenance free stainless steel Spherical Plain Bearing GE..EC-NIRO (see page 71)

Hydraulic Rod Ends - Weld-On Base

Series FS...N

Rod Ends with rectangular surface for Weld-on. Spherical Plain Bearings, regreasable, fixed with snap rings

For Weld-On to cylinder bottoms

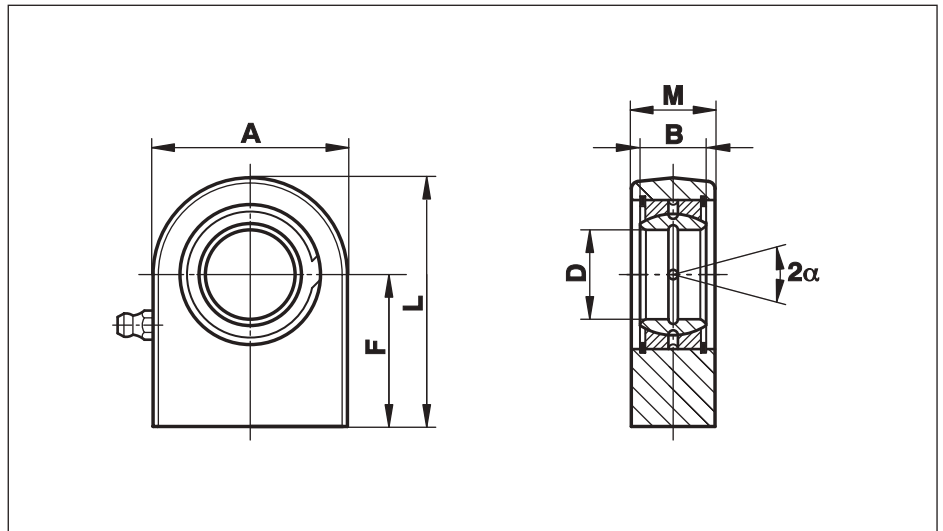

| Size (D) | B | M | A | F | L | Static load C ₀ kN | Dynamic load C kN | Maximum Pivoting Angle α (°) | Weight g |
|----------|----|------|-----|-----|-------|-------------------------------|-------------------|------------------------------|----------|
| 15 | 12 | 16,0 | 45 | 31 | 53,5 | 53,0 | 17,0 | 8 | 220 |
| 16 | 14 | 17,5 | 48 | 35 | 59,0 | 59,0 | 21,2 | 10 | 290 |
| 17 | 14 | 17,5 | 48 | 35 | 59,0 | 65,0 | 21,2 | 10 | 290 |
| 20 | 16 | 19,0 | 50 | 38 | 63,0 | 67,0 | 30,0 | 9 | 360 |
| 25 | 20 | 23,0 | 55 | 45 | 72,5 | 69,5 | 48,0 | 7 | 530 |
| 30 | 22 | 28,0 | 65 | 51 | 83,5 | 118,0 | 62,0 | 6 | 850 |
| 35 | 25 | 30,0 | 83 | 61 | 102,5 | 196,0 | 80,0 | 6 | 1500 |
| 40 | 28 | 35,0 | 100 | 69 | 119,0 | 305,0 | 100,0 | 7 | 2420 |
| 45 | 32 | 40,0 | 110 | 77 | 132,0 | 386,0 | 127,0 | 7 | 3390 |
| 50 | 35 | 40,0 | 123 | 88 | 149,5 | 441,0 | 156,0 | 6 | 4240 |
| 60 | 44 | 50,0 | 140 | 100 | 170,0 | 570,0 | 245,0 | 6 | 7100 |
| 70 | 49 | 55,0 | 164 | 115 | 197,0 | 724,0 | 315,0 | 6 | 10700 |
| 80 | 55 | 60,0 | 180 | 141 | 231,0 | 804,0 | 400,0 | 6 | 15100 |
| 90 | 60 | 65,0 | 226 | 150 | 263,0 | 1340,0 | 490,0 | 5 | 23400 |
| 100 | 70 | 70,0 | 250 | 170 | 295,0 | 1516,0 | 610,0 | 7 | 33100 |
| 110 | 70 | 80,0 | 295 | 185 | 332,5 | 2340,0 | 655,0 | 6 | 48500 |
| 120 | 85 | 90,0 | 360 | 210 | 390,0 | 3210,0 | 950,0 | 6 | 79500 |

Materials:

Housing: St 52-3, forged

Bearing: Steel on Steel bearing GE...E, requiring maintenance

Greasing: fitted with hydraulic grease nipple to DIN 71412

On request: Housing: Stainless steel to 1.4401
with maintenance free stainless steel Spherical Plain Bearing GE..EC-NIRO (see page 71)

Angle Joints

Angle Joints to DIN 71802

consisting of ball stud to DIN 71803 and ball journal to DIN 71805

Form C with threaded stud and hexagon nut.

Form CS with threaded stud, hexagon nut and external clip

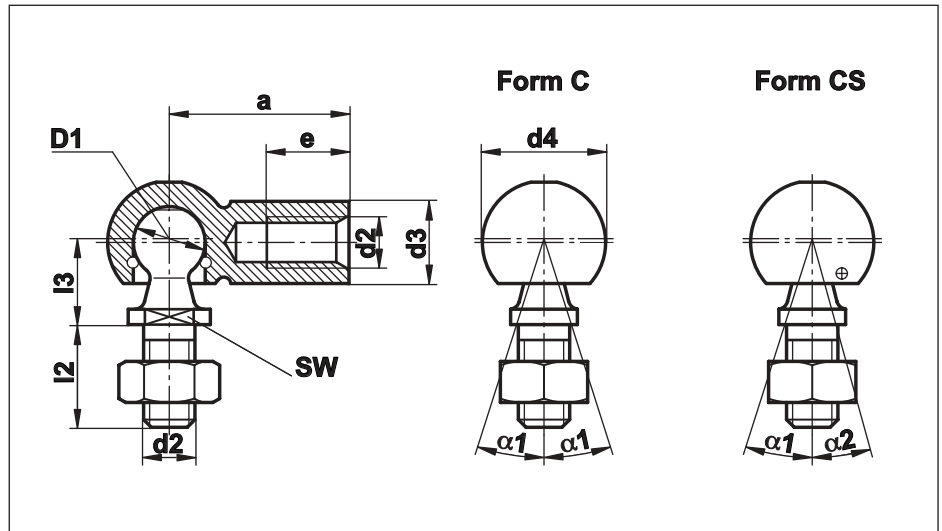

| Size (D) | a ±0,3 | d2 | d3 ±0,5 | d4 ±0,5 | e min | l2 ±0,3 | l3 ±0,3 | SW h14 | α 1 (°) | α 2 (°) | Weight g |
|----------|--------|----------|---------|---------|-------|---------|---------|--------|---------|---------|----------|
| 8 | 22 | M 5 | 8 | 12,8 | 10,2 | 10,2 | 9 | 7 | 18 | 10 | 15,2 |
| 10 | 25 | M 6 | 10 | 14,8 | 11,5 | 12,5 | 11 | 8 | 18 | 15 | 25,2 |
| 13 | 30 | M 8 | 13 | 19,3 | 14,0 | 16,5 | 13 | 11 | 18 | 15 | 53,1 |
| 16 | 35 | M 10 | 16 | 24,0 | 15,5 | 20,0 | 16 | 13 | 18 | 15 | 104,0 |
| 16 | 35 | M 12 | 16 | 24,0 | 15,5 | 20,0 | 16 | 13 | 18 | 15 | 104,0 |
| 19 | 45 | M 14x1,5 | 22 | 30,0 | 21,5 | 28,0 | 20 | 16 | 18 | 15 | 221,0 |
| 19 | 45 | M 14x2 | 22 | 30,0 | 21,5 | 28,0 | 20 | 16 | 18 | 15 | 221,0 |

Materials:

Ball Journal: Steel, minimum strength $R_m = 500\text{N/mm}^2$

Ball Stud: Steel, minimum strength $R_m = 600\text{N/mm}^2$

Surface: blanc, zinc plated white, on request: yellow or black chromated

Alternative: stainless steel to 1.4305, Aisi 303

Ordering Details:

e.g. Angle Joint with external clip, Form CS with ball diameter $D_1 = 10\text{ mm}$:

Angle Joint DIN 71802 - CS 10

Left Hand Thread: Left hand thread only at the ball journal available:

Angle Joint DIN 71802 - CS 10 LH

Loose Fit: increased internal clearance available:

Angle Joint DIN 71802 - CSL 10

Fork Heads / Fork Ball Joints

Fork Heads to DIN 71752 Fork Ball Joints to DIN 71751

With ES-Bolt (clevis
spring pin) or cotter bolt

For use to transmit
linear movements

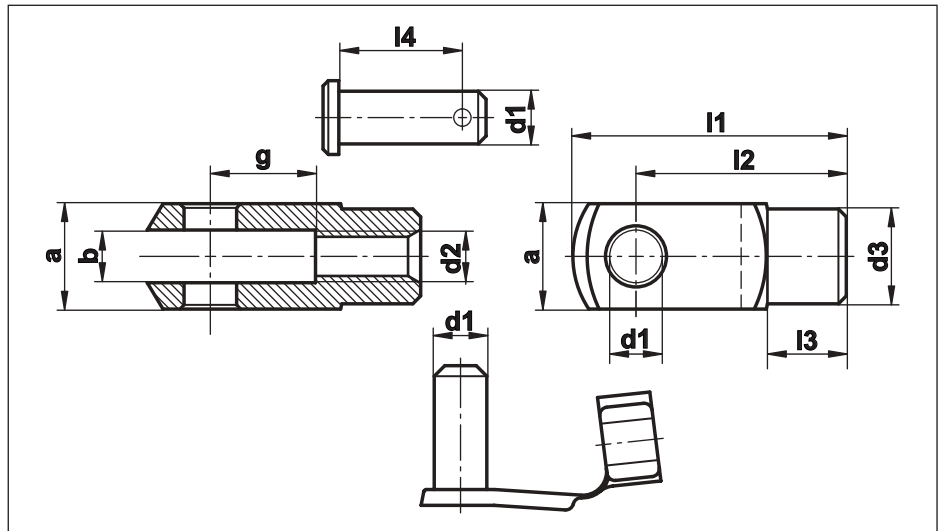

| Size | g | a | b B13 | d1 H9/h11 | d2 | d3 | l1 | l2 | l3 | l4 | Weight g | | |
|-------|----|----|----------|--------------|------|----|-----|----|------|------|----------|-------------|------------------------|
| | | | | | | | | | | | ES-Bolt | Cotter Bolt | Fork Head DIN 71752 |
| 4x8 | 8 | 8 | 4 | 4 | M 4 | 8 | 21 | 16 | 6,0 | 9,2 | 1,5 | 1,4 | 5 |
| 4x16 | 16 | | | | | | 29 | 24 | | | 7 | | |
| 5x10 | 10 | 10 | 5 | 5 | M 5 | 9 | 26 | 20 | 7,5 | 12,0 | 2,7 | 2,4 | 9 |
| 5x20 | 20 | | | | | | 36 | 30 | | | 13 | | |
| 6x12 | 12 | 12 | 6 | 6 | M 6 | 10 | 31 | 24 | 9,0 | 14,5 | 4,6 | 4,4 | 15 |
| 6x24 | 24 | | | | | | 43 | 36 | | | 22 | | |
| 8x16 | 16 | 16 | 8 | 8 | M 8 | 14 | 42 | 32 | 12,0 | 18,7 | 10,4 | 9,4 | 37 |
| 8x32 | 32 | | | | | | 58 | 48 | | | 54 | | |
| 10x20 | 20 | 20 | 10 | 10 | M 10 | 18 | 52 | 40 | 15,0 | 23,2 | 19,0 | 17,8 | 74 |
| 10x40 | 40 | | | | | | 72 | 60 | | | 116 | | |
| 12x24 | 24 | 24 | 12 | 12 | M 12 | 20 | 62 | 48 | 18,0 | 28,2 | 33,5 | 33,6 | 121 |
| 12x48 | 48 | | | | | | 86 | 72 | | | 175 | | |
| 14x28 | 28 | 27 | 14 | 14 | M 14 | 24 | 72 | 56 | 22,5 | 31,2 | 45,0 | 50,7 | 178 |
| 14x56 | 56 | | | | | | 101 | 85 | | | 258 | | |
| 16x32 | 32 | 32 | 16 | 16 | M 16 | 26 | 83 | 64 | 24,0 | 36,2 | 70,0 | 74,7 | 282 |
| 16x64 | 64 | | | | | | 115 | 96 | | | 410 | | |
| 20x40 | 40 | 40 | 20 | 20 | M 20 | 34 | 105 | 80 | 30,0 | 47,0 | 132,0 | 130,0 | 520 |

Materials:

Standard Series: free-cutting steel to 9SMnPb28K, 12L13, tensile strength 550 to 700 N/mm²
Surface: zinc plated and chromated, on request: blanc, oiled or phosphated and oiled

On request: stainless series, stainless steel to 1.4305, Aisi 303
ES-Bolt not in stainless steel available

Ordering Details:

Fork Head: e.g. Form G with bore size **d1** = 12mm, split length **g** = 24mm:
Fork Head DIN 71752-G12x24

Fork Ball Joint: e.g. Fork Ball Joint with Cotter Bolt, with bore size **d1** = 12mm, split length **g** = 24mm:
Fork Ball Joint DIN 71751-A12x24

e.g. Left Hand Thread: **DIN 71752-G12x24LH** and **DIN 71751-A12x24LH**

Rubber Seals

RERS

Rubber Protector Caps
made from Neoprene

Protects against dust, chemical substances and aggressive environment. Resistant to oil, grease, saltwater, chemical components and other substances.

Temperature range from -20° till +120° Celsius or -4° till +248° Fahrenheit.

Can be completely filled with grease. Mounted easily with Seeger retaining pliers

* Spacers separately on request

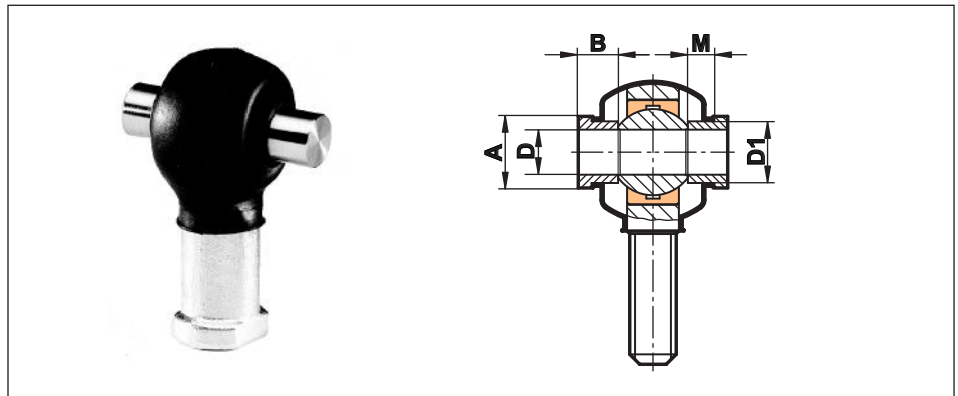

| Rod End Size | Rubber Protector Cap Type | Spacers Type* | D | D1 | B | M | A |
|--------------|---------------------------|---------------|----|------|----|---|----|
| 6 | RERS 1 | DR 6 | 6 | 8,7 | 6 | 4 | 11 |
| 8 | RERS 1 | DR 8 | 8 | 10,3 | 6 | 4 | 12 |
| 10 | RERS 2 | DR 10 | 10 | 12,5 | 6 | 4 | 14 |
| 12 | RERS 2 | DR 12 | 12 | 15,0 | 8 | 6 | 17 |
| 14 | RERS 3 | DR 14 | 14 | 16,8 | 8 | 6 | 19 |
| 16 | RERS 3 | DR 16 | 16 | 19,0 | 8 | 6 | 21 |
| 18 | RERS 3 | DR 18 | 18 | 21,8 | 8 | 6 | 25 |
| 20 | RERS 4 | DR 20 | 20 | 24,3 | 10 | 8 | 28 |
| 22 | RERS 4 | DR 22 | 22 | 25,7 | 10 | 8 | 29 |
| 25 | RERS 4 | DR 25 | 25 | 29,7 | 10 | 8 | 33 |
| 30 | RERS 5 | | | | | | |
| 35 | RERS 5 | | | | | | |

RELS

Washer Seals
Rubber Seals
vulcanized to
stainless steel washer
rings

Prevents dirt entering the mating surface.
Easily mounted.
Temperature resistant up to +110° Celsius or +230° Fahrenheit

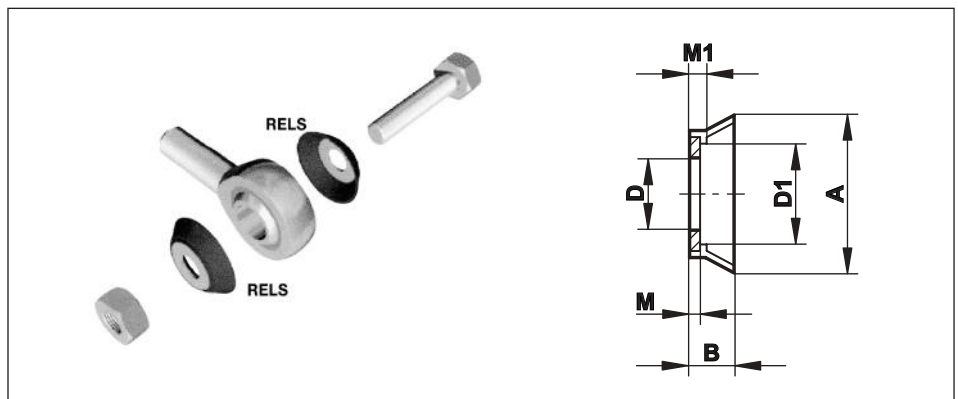

| Rod End / Spherical Plain Bearing size | Washer Seal Type | D | D1 | B | M | M1 | A |
|--|------------------|-------|------|------|------|-----|------|
| 5 | RELS 5 | 5,25 | 8,3 | 2,4 | 0,50 | 0,8 | 11,2 |
| 6 | RELS 6 | 6,25 | 9,5 | 3,1 | 0,69 | 0,9 | 12,7 |
| 8 | RELS 8 | 8,25 | 12,4 | 5,1 | 1,20 | 1,4 | 17,8 |
| 10 | RELS 10 | 10,25 | 13,5 | 5,6 | 1,20 | 1,4 | 20,3 |
| 12 | RELS 12 | 12,25 | 18,5 | 6,4 | 1,20 | 1,7 | 28,6 |
| 14 | RELS 14 | 14,25 | 18,5 | 6,4 | 1,20 | 1,7 | 28,6 |
| 16 | RELS 16 | 16,25 | 22,4 | 6,8 | 1,20 | 1,7 | 31,7 |
| 18 | RELS 18 | 18,25 | 22,6 | 8,3 | 1,20 | 1,7 | 32,7 |
| 20 | RELS 20 | 20,25 | 25,2 | 10,2 | 1,20 | 1,7 | 38,1 |
| 25 | RELS 25 | 25,25 | 33,8 | 12,7 | 1,50 | 2,3 | 53,3 |
| 30 | RELS 30 | 30,25 | 55,9 | 14,0 | 1,50 | 2,3 | 56,7 |

Jam Nuts to DIN 934 / 439

Normal Form
DIN 934 / ISO 4032

Narrow Form
DIN 439 / 936

Jam Nuts with right or left hand thread. Steel zinc plated or stainless Steel A2

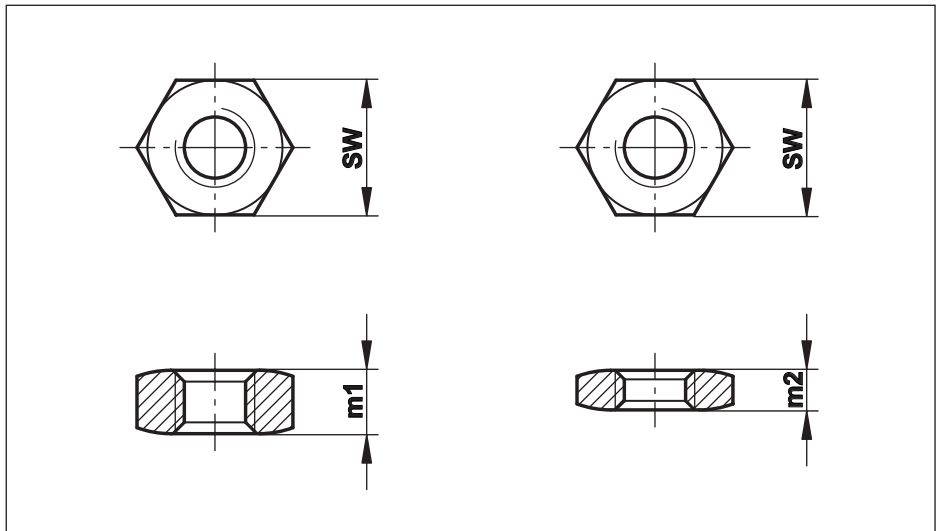

| Nominal Size | Standard Thread Pitch | SW | Thread Pitch M ... | | | | | | | | | | | | ISO 4032/DIN934 | | ISO 4036/DIN439 | |
|--------------|-----------------------|------|--------------------|------|------|------|------|-------|------|-------|------|------|------|------|-----------------|----------|-----------------|----------|
| | | | x0,4 | x0,5 | x0,7 | x0,8 | x1,0 | x1,25 | x1,5 | x1,75 | x2,0 | x2,5 | x3,0 | x4,0 | m1 | Weight g | m2 | Weight g |
| M 3 | (M 3x0,5) | 5,5 | | X | | | | | | | | | | | 2,4 | 0,4 | 1,8 | 0,3 |
| M 4 | (M 4x0,7) | 7,0 | | | X | | | | | | | | | | 3,2 | 0,8 | 2,2 | 0,6 |
| M 5 | (M 5x0,8) | 8,0 | | | | X | | | | | | | | | 4,0 | 1,2 | 2,7 | 0,8 |
| M 6 | (M 6x1) | 10,0 | | | | | X | | | | | | | | 5,0 | 2,4 | 3,2 | 1,5 |
| M 8 | (M 8x1,25) | 13,0 | | | | | X | X | | | | | | | 6,5 | 5,1 | 4,0 | 3,1 |
| M 10 | (M10x1,5) | 17,0 | | | | | X | X | X | | | | | | 8,0 | 11,1 | 5,0 | 6,9 |
| M 12 | (M 12x1,75) | 19,0 | | | | | | X | X | X | | | | | 10,0 | 16,3 | 6,0 | 9,8 |
| M 14 | (M 14x2) | 22,0 | | | | | | | | | X | | | | 11,0 | 24,0 | 7,0 | 15,0 |
| M 16 | (M 16x2) | 24,0 | | | | | | | X | | X | | | | 13,0 | 32,0 | 8,0 | 19,5 |
| M 18 | (M 18x2,5) | 27,0 | | | | | | | X | | | | | | 15,0 | 47,0 | 9,0 | 28,0 |
| M 20 | (M 20x2,5) | 30,0 | | | | | | | X | | | X | | | 16,0 | 61,0 | 10,0 | 38,0 |
| M 22 | (M22x2,5) | 32,0 | | | | | | | X | | | | | | 18,0 | 75,0 | 11,0 | 46,0 |
| M 24 | (M 24x3) | 36,0 | | | | | | | | | X | | | | 19,0 | 104,0 | 12,0 | 66,0 |
| M 27 | (M 27x3) | 41,0 | | | | | | | | | X | | | | 22,0 | 158,0 | 13,5 | 96,0 |
| M 30 | (M 30x3,5) | 46,0 | | | | | | | | | X | | | | 24,0 | 219,0 | 15,0 | 137,0 |
| M 36 | (M 36x4) | 55,0 | | | | | | | | | X | | X | | 29,0 | 370,0 | 18,0 | 230,0 |
| M 39 | (M 39x4) | 60,0 | | | | | | | | | | | X | | 31,0 | 470,0 | 19,5 | 300,0 |
| M 42 | (M 42x4,5) | 65,0 | | | | | | | | | X | | X | | 34,0 | 610,0 | 21,0 | 380,0 |
| M 45 | (M 45x4,5) | 70,0 | | | | | | | | | | | X | | 36,0 | 750,0 | 22,5 | 470,0 |
| M 48 | (M 48x5) | 75,0 | | | | | | | | | X | | | | 38,0 | 910,0 | 24,0 | 580,0 |
| M 52 | (M 52x5) | 80,0 | | | | | | | | | | | X | | 42,0 | 1130,0 | 26,0 | 700,0 |
| M 56 | (M 56x5,5) | 85,0 | | | | | | | | | | | | X | 45,0 | 1350,0 | 28,0 | 840,0 |
| M 64 | (M 64x6) | 95,0 | | | | | | | | | | | | X | 51,0 | 1850,0 | 32,0 | 1160,0 |

X) available ex stock, Standard Form only with standard thread in stock

Materials: steel galvanised, strength grade: 04 or better, or alternative A2 (which is equivalent to stainless steel 1.4301, Aisi 304 and 1.4303, Aisi 305)

Thread: Right hand or left hand threads

Remarks: Across-flats dimension SW, Weight, Width m1/m2 and Chamfer can differ from the table above and the DIN, because of different manufacturing methods
Jam Nuts DIN 439 according to **ISO 4036** (without chamfer) or **ISO 4035** (with chamfer).
Jam Nuts DIN 439 Fine Thread according to **ISO 8675** (with chamfer).

Ordering e.g. **Jam Nut M 10 Left Hand** (Normal Form with standard thread) in stainless steel A2:

Details: **Jam Nut DIN 934-M10-A2-Left Hand**

e.g. **Jam Nut M 39x3 Right Hand** (Narrow Form) in Steel, zinc plated:

Jam Nut DIN 439-M39x3-04

Cylindrical bearings

Characteristics:

- suitable for dry run with a low friction coefficient
- low wear rate
- good sliding properties
- suitable for rotating and oscillating movements
- high chemical resistance
- low absorption of water
- work also lubricated

Quality:

- material thickness PTFE/fiber blend 0,01 - 0,03 mm mixed with sintered bronze powder with a thickness of 0,20 - 0,35 mm.

- Bushing of low-carbon steel:
 - unusually high load-bearing capacity
 - excellent heat conduction
 - copper-tin coated, coating thickness 2 µm
 - **has a very good corrosion resistance**

Application field:

- for a long durability with or without lubrication
- automotive sector, household appliances, conveyor technology, ships' engines, hydraulic technology, textile industry, machine tools, etc.

- Bronze bushing:
 - unusually high load-bearing capacity
 - excellent heat conduction
 - has a very good corrosion resistance

- Bushing of stainless steel:
 - has a very good corrosion resistance

Application field:

- for a long durability with or without lubrication
- **cement delivery pumps, conveyor technology, molding machines, etc.**

| Characteristics: | | Bushing of steel | Bronze bushing |
|----------------------------|-------------------------|------------------|----------------|
| max. static load | N/mm ² | 250 | 140 |
| max. dynamic load | N/mm ² | 80 | 80 |
| compressive strength | N/mm ² | 350 | 300 |
| max. sliding speed | m/s | 2 | 2 |
| friction coefficient μ | - | 0,03 bis 0,08 | 0,03 bis 0,08 |
| temperature range | °C | -200 bis +250 | -200 bis +250 |
| PV _{max} | N/mm ² x m/s | 1,8 | 1,8 |

Cylindrical bearings

Series BK1...

Cylindrical plain bushing

Auskleidung mit einer PTFE/Fasermischung.

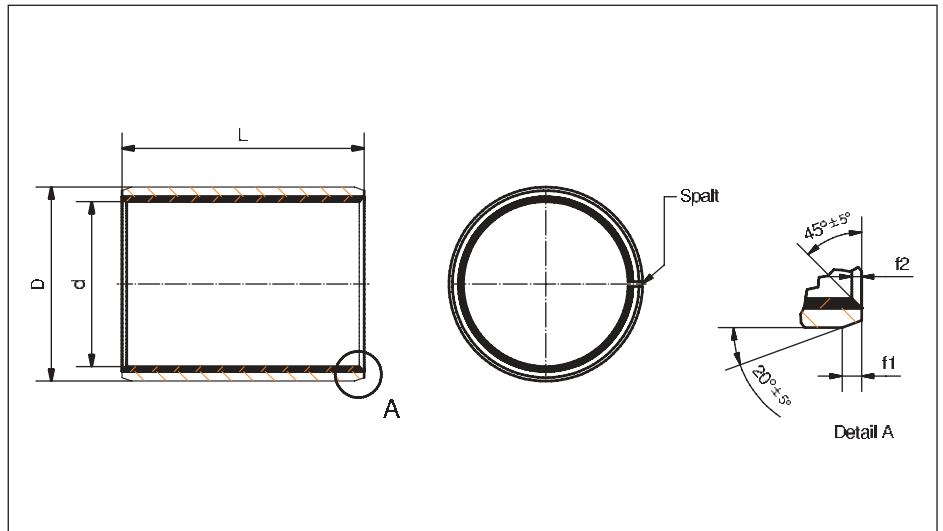

| Size (D) | D | Wall thickness min/max | f1 | f2 | L 0 / -0,4 | | | | | | | | | | | | | | | |
|----------|-------|------------------------|-----|-----|------------|---|---|---|----|----|----|----|----|----|----|----|---|---|--|--|
| | | | | | 4 | 5 | 6 | 8 | 10 | 12 | 15 | 20 | 25 | 30 | 40 | 50 | | | | |
| 3 | 4,50 | 0,730 | 0,5 | 0,3 | X | X | X | | | | | | | | | | | | | |
| 4 | 5,50 | 0,750 | | | X | | | | | | | | | | | | | | | |
| 5 | 7,00 | 0,980 1,005 | | | | | | X | | | | | | | | | | | | |
| 6 | 8,00 | | | | | | | | X | X | X | | | | | | | | | |
| 8 | 10,00 | | | | | | | | | X | X | X | X | | | | | | | |
| 10 | 12,00 | | | | | | | | | X | X | X | X | X | | | | | | |
| 12 | 14,00 | | | | | | | | | X | X | X | X | X | X | | | | | |
| 13 | 15,00 | | | | | | | | | | X | | | X | | | | | | |
| 14 | 16,00 | | | | | | | | | | X | X | X | X | X | | | | | |
| 15 | 17,00 | | | | | | | | | | X | X | X | X | X | | | | | |
| 16 | 18,00 | | | | | | | | | | X | X | X | X | X | | | | | |
| 17 | 19,00 | | | | | | | | | | X | | X | X | | | | | | |
| 18 | 20,00 | | | | | | | | | X | X | X | X | X | | | | | | |
| 20 | 23,00 | 1,475 1,505 | 0,8 | 0,4 | | | | X | X | X | X | X | X | X | | | | | | |
| 22 | 25,00 | | | | | | | | | X | X | X | X | X | X | | | | | |
| 24 | 27,00 | | | | | | | | | | | X | X | X | X | | | | | |
| 25 | 28,00 | | | | | | | | | | | X | X | X | X | X | X | X | | |
| 28 | 32,00 | | | | | | | | | | | X | X | X | X | X | X | X | | |
| 30 | 34,00 | 1,970 2,005 | 1,0 | 0,6 | | | | | X | X | X | X | X | X | X | | | | | |
| 32 | 36,00 | | | | | | | | | | | | X | | X | X | | | | |
| 35 | 39,00 | | | | | | | | | | | X | X | X | X | X | X | X | | |
| 38 | 42,00 | | | | | | | | | | | | X | | | X | X | | | |
| 40 | 44,00 | | | | | | | | | | | X | | X | X | X | X | X | | |

Cylindrical bearings

| Size (D) | D | Wall thickness min/max | f1 | f2 | L 0 / -0,4 | | | | | | | | | | |
|-------------|--------|---------------------------|-----|-----|------------|----|----|----|----|----|----|----|-----|-----|--|
| | | | | | 20 | 25 | 30 | 40 | 50 | 60 | 70 | 80 | 100 | 115 | |
| 45 | 50,00 | 2,460 2,505 | 1,2 | 0,8 | X | X | X | X | X | | | | | | |
| 50 | 55,00 | | | | X | | X | X | X | X | | | | | |
| 55 | 60,00 | | | | | | X | X | X | X | | | | | |
| 60 | 65,00 | | | | | | X | X | X | X | X | | | | |
| 65 | 70,00 | | | | | | X | X | X | X | X | X | | | |
| 70 | 75,00 | | | | | | | X | X | X | X | X | X | | |
| 75 | 80,00 | | | | | | | X | X | X | X | X | X | | |
| 80 | 85,00 | 2,440 2,490 | 1,4 | 0,8 | | | X | X | X | X | X | | X | | |
| 85 | 90,00 | | | | | | X | | X | | X | X | | X | |
| 90 | 95,00 | | | | | | X | X | X | | X | X | | X | |
| 95 | 100,00 | | | | | | | X | X | | X | X | | X | |
| 100 | 105,00 | | | | | | | X | X | | X | | | X | |
| 105 | 110,00 | | | | | | | | | | X | X | | X | |
| 110 | 115,00 | | | | | | | | | | X | X | | X | |
| 115 | 120,00 | 2,415 2,465 | 1,4 | 0,8 | | | | | X | X | | | X | | |
| 120 | 125,00 | | | | | | X | | X | | X | X | | X | |
| 125 | 130,00 | | | | | | X | | X | | X | X | | X | |
| 130 | 135,00 | | | | | | X | | X | | X | X | | X | |
| 140 | 145,00 | | | | | | X | | X | | X | X | | X | |
| 150 | 155,00 | | | | | | X | | X | | X | X | | X | |
| 160 | 165,00 | | | | | | | | | | | | X | | |
| 180 | 185,00 | | | | | | | | | | | | X | | |
| 190 | 195,00 | | | | | | | | | | | | X | | |
| 200 | 205,00 | | | | | | | | | | | | X | | |
| 220 | 225,00 | | | | | | | | | | | | X | | |
| 250 | 255,00 | | | | | | | | | | | | X | | |
| 260 | 265,00 | | | | | | | | | | | | X | | |
| 280 | 285,00 | | | | | | | | | X | | | | | |
| 300 | 305,00 | | | | | | | | | X | | | | | |

Materials:

Bushing:

- low-carbon steel lined with a PTFE/fibre mixture/blend
- Bronze lined with a PTFE/fibre mixture/blend
- Stainless steel lined with a PTFE/fibre mixture/blend

Recommendation for the assembly:

- housing bore H7
- shaft diameter f7
- the gap must not be in the load direction

Cylindrical bearings

Series BK1..BU

Cylindrical plain bushing with collar

lined with a PTFE/fibre mixture/blend

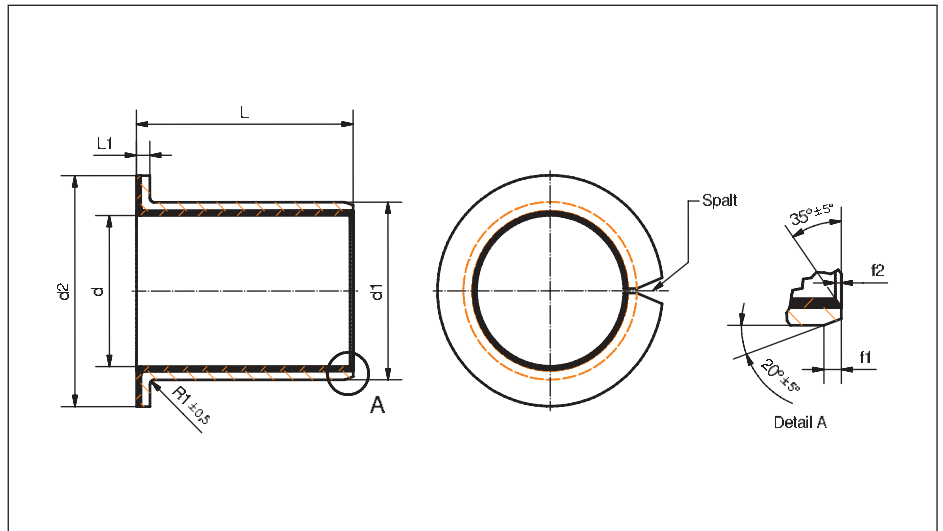

| Size (d) | d1 | d2 ± 0,5 | L1 -0,2 | f1 | f2 | L ± 0,25 | | | | | | | | | | | | | | | |
|----------|----|----------|---------|-----|-----|----------|-----|-------|---|-------|------|----|---------|----|---------|----|----|----|---|---|--|
| | | | | | | 4 | 5,5 | 7/7,5 | 8 | 9/9,5 | 11,5 | 12 | 16/16,5 | 17 | 21,5/22 | 26 | 31 | 41 | | | |
| 6 | 8 | 12 | 1,0 | 0,5 | 0,3 | x | | x | x | | | | | | | | | | | | |
| 8 | 10 | 15 | | | | | x | x | | x | | | | | | | | | | | |
| 10 | 12 | 18 | | | | | x | x | | x | | | | | | | | | | | |
| 12 | 14 | 20 | | | | | x | x | | x | | | x | | x | | | | | | |
| 14 | 16 | 22 | | | | | | | | | | | x | | x | | | | | | |
| 15 | 17 | 23 | | | | | | | | | | | x | | x | | | | | | |
| 16 | 18 | 24 | | | | | | | | | | | x | | x | | | | | | |
| 18 | 20 | 26 | | | | | | | | | | | x | | x | | x | | | | |
| 20 | 23 | 30 | 1,5 | 0,8 | 0,4 | | | | | x | | x | | x | | | | | | | |
| 22 | 25 | 32 | | | | | | | | | | x | | x | | x | | | | | |
| 24 | 27 | 34 | | | | | | | | | | | x | | x | | x | | | | |
| 25 | 28 | 35 | | | | | | | | | | | x | | x | | x | | | | |
| 28 | 32 | 40 | | | | | | | | | | | | | | | x | | | | |
| 30 | 34 | 42 | | | | | | | | | | | | | x | | | x | | | |
| 32 | 36 | 44 | 2,0 | 1,0 | 0,6 | | | | | | | | | x | | | | | | | |
| 35 | 39 | 47 | | | | | | | | | | | | | x | | | x | | | |
| 38 | 42 | 51 | | | | | | | | | | | | | | | | | x | | |
| 40 | 44 | 53 | | | | | | | | | | | | | | | | | x | x | |
| 50 | 55 | 65 | 2,5 | 1,2 | 0,8 | | | | | | | | | | | | x | x | | | |
| 60 | 65 | 75 | | | | | | | | | | | | | | | | | x | x | |

Materials:

Bushing:

- low-carbon steel lined with a PTFE/fibre mixture/blend
- Bronze lined with a PTFE/fibre mixture/blend
- Stainless steel lined with a PTFE/fibre mixture/blend

Recommendation for the assembly:

- housing bore H7
- shaft diameter f7
- the gap must not be in the load direction

Cylindrical bearings

Series

BK1-Druckscheibe

coated with a PTFE/fibre mixture/blend

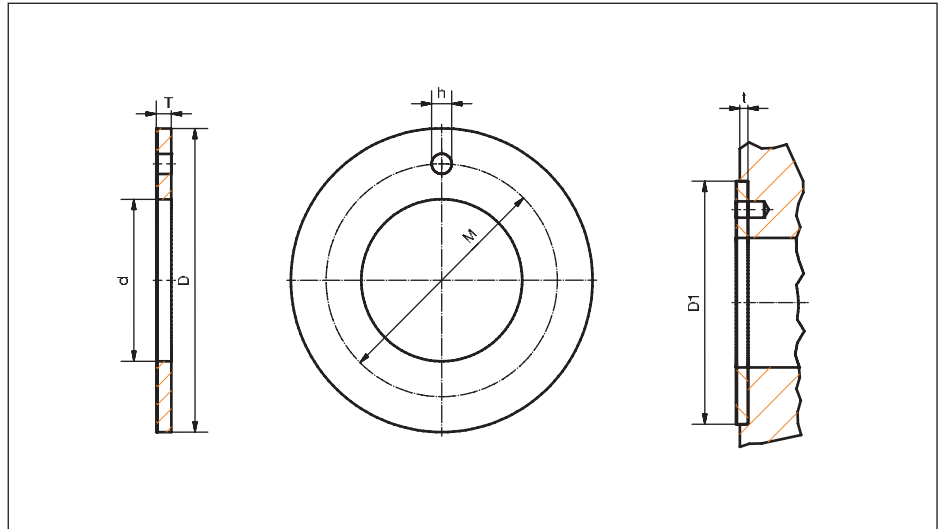

| Size d +0,25 | D -0,25 | T -0,05 | M ±0,125 | h +0,4/+0,1 | t ±0,2 | D1 +0,12 |
|--------------------|------------|------------|-------------|----------------|-----------|-------------|
| 10 | 20 | 1,5 | 15 | 1,5 | 1,0 | 20 |
| 12 | 24 | | 18 | | | 24 |
| 14 | 26 | | 20 | | | 26 |
| 16 | 30 | | 23 | 2,0 | | 30 |
| 18 | 32 | | 25 | | | 32 |
| 20 | 36 | | 28 | 3,0 | | 36 |
| 22 | 38 | | 30 | | | 38 |
| 24 | 42 | | 33 | | | 42 |
| 26 | 44 | | 35 | | | 44 |
| 28 | 48 | | 38 | 4,0 | | 48 |
| 32 | 54 | 43 | 54 | | | |
| 38 | 62 | 50 | 62 | | | |
| 42 | 66 | 54 | 66 | | | |
| 48 | 74 | 61 | 1,5 | | 74 | |
| 52 | 78 | 65 | | | 78 | |
| 62 | 90 | 76 | | 90 | | |

Materials:

- Disc:**
- low-carbon steel lined with a PTFE/fibre mixture/blend
 - bronze lined with a PTFE/fibre mixture/blend
 - stainless steel lined with a PTFE/fibre mixture/blend

Bearing block for hydraulic cylinders

Series IKA..

Bearing block

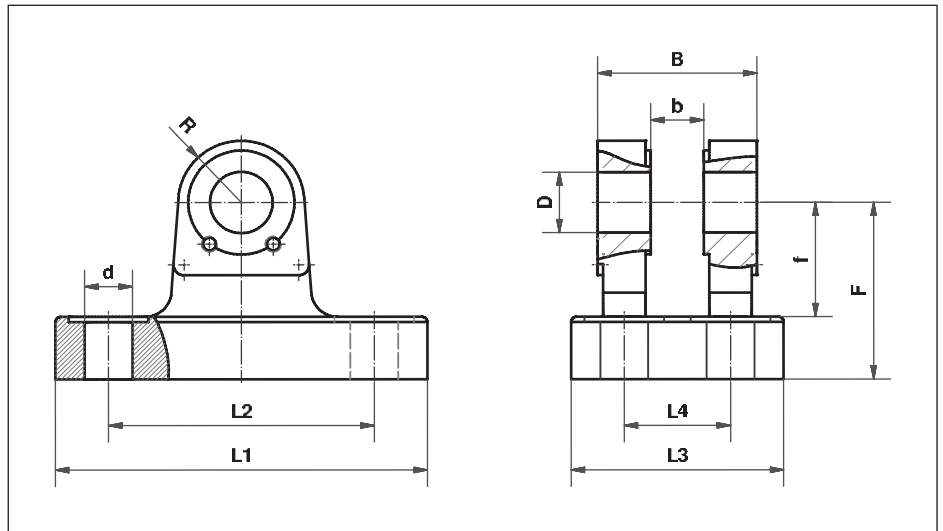

| Size D (H9) | B (h16) | L1 | L2 (JS14) | L3 | L4 (JS14) | d (H13) | R | F (JS12) | f min. | b (A13) | load max. (kN) | Weight g |
|-------------|---------|-----|-----------|-----|-----------|---------|-----|----------|--------|---------|----------------|----------|
| 10 | 24 | 60 | 42 | 33 | 17 | 6,6 | 10 | 32 | 22 | 10 | 5,0 | 100 |
| 12 | 28 | 70 | 50 | 40 | 20 | 9,0 | 12 | 34 | 22 | 12 | 8,0 | 310 |
| 16 | 36 | 90 | 65 | 50 | 26 | 11,0 | 16 | 40 | 27 | 16 | 12,5 | 590 |
| 20 | 45 | 98 | 75 | 58 | 32 | 11,0 | 20 | 45 | 30 | 20 | 20,0 | 900 |
| 25 | 56 | 113 | 85 | 70 | 40 | 13,5 | 25 | 55 | 37 | 25 | 32,0 | 1600 |
| 32 | 70 | 143 | 110 | 85 | 50 | 17,5 | 32 | 65 | 43 | 32 | 50,0 | 2800 |
| 40 | 90 | 170 | 130 | 108 | 65 | 22,0 | 40 | 76 | 52 | 40 | 80,0 | 5000 |
| 50 | 110 | 220 | 170 | 130 | 80 | 26,0 | 50 | 95 | 65 | 50 | 125,0 | 10100 |
| 63 | 140 | 270 | 210 | 160 | 100 | 33,0 | 63 | 112 | 75 | 63 | 200,0 | 15400 |
| 80 | 170 | 320 | 250 | 210 | 125 | 39,0 | 80 | 140 | 95 | 80 | 320,0 | 30000 |
| 100 | 210 | 400 | 315 | 260 | 160 | 45,0 | 100 | 180 | 120 | 100 | 500,0 | 60200 |

Materials:

Housing: spheroidal graphite cast iron EN-GJS 500/7

Bearing block for hydraulic cylinders

Series IKB..

Bearing block

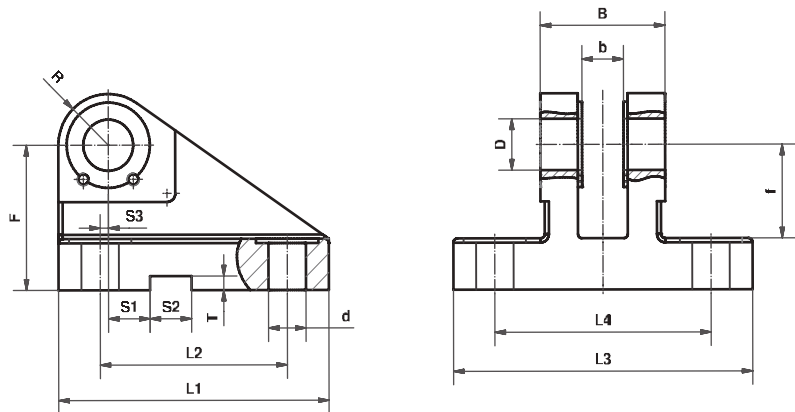

| Size D (H9) | B (h16) | L1 | L2 (js13) | L3 | L4 | d (H13) | R | F (js13) | f min. | b (A13) | S1 (JS14) | S2 (N9) | S3 (JS14) | T (+0,3) | load max. (kN) | Weight g |
|-------------|---------|-----|-----------|-----|-----|---------|-----|----------|--------|---------|-----------|---------|-----------|----------|----------------|----------|
| 10 | 24 | 60 | 44 | 56 | 39 | 6,6 | 10 | 32 | 22 | 10 | 10 | 8 | 2,0 | 3,3 | 5,0 | 310 |
| 12 | 28 | 65 | 45 | 72 | 52 | 9,0 | 12 | 34 | 22 | 12 | 10 | 10 | 2,0 | 3,3 | 8,0 | 550 |
| 16 | 36 | 80 | 55 | 90 | 65 | 11,0 | 16 | 40 | 27 | 16 | 10 | 16 | 3,5 | 4,3 | 12,5 | 900 |
| 20 | 45 | 95 | 70 | 100 | 75 | 11,0 | 20 | 45 | 30 | 20 | 10 | 16 | 7,5 | 4,3 | 20,0 | 1500 |
| 25 | 56 | 115 | 85 | 120 | 90 | 13,5 | 25 | 55 | 37 | 25 | 10 | 25 | 10,0 | 5,4 | 32,0 | 2700 |
| 32 | 70 | 145 | 110 | 145 | 110 | 17,5 | 32 | 65 | 43 | 32 | 6 | 25 | 14,5 | 5,4 | 50,0 | 4500 |
| 40 | 90 | 170 | 125 | 185 | 140 | 22,0 | 40 | 76 | 52 | 40 | 6 | 36 | 17,5 | 8,4 | 80,0 | 8500 |
| 50 | 110 | 200 | 150 | 215 | 165 | 26,0 | 50 | 95 | 65 | 50 | - | 36 | 25,0 | 8,4 | 125,0 | 13500 |
| 63 | 140 | 230 | 170 | 270 | 210 | 33,0 | 63 | 112 | 75 | 63 | - | 50 | 33,0 | 11,4 | 200,0 | 23400 |
| 80 | 170 | 280 | 210 | 320 | 250 | 39,0 | 80 | 140 | 95 | 80 | - | 50 | 45,0 | 11,4 | 320,0 | 38500 |
| 100 | 210 | 345 | 250 | 405 | 315 | 52,0 | 100 | 180 | 120 | 100 | - | 63 | 52,5 | 12,4 | 500,0 | 90300 |

Materials:

Housing: spheroidal graphite cast iron EN-GJS 500/7

Bearing block for hydraulic cylinders

Series DK..

Bearing block

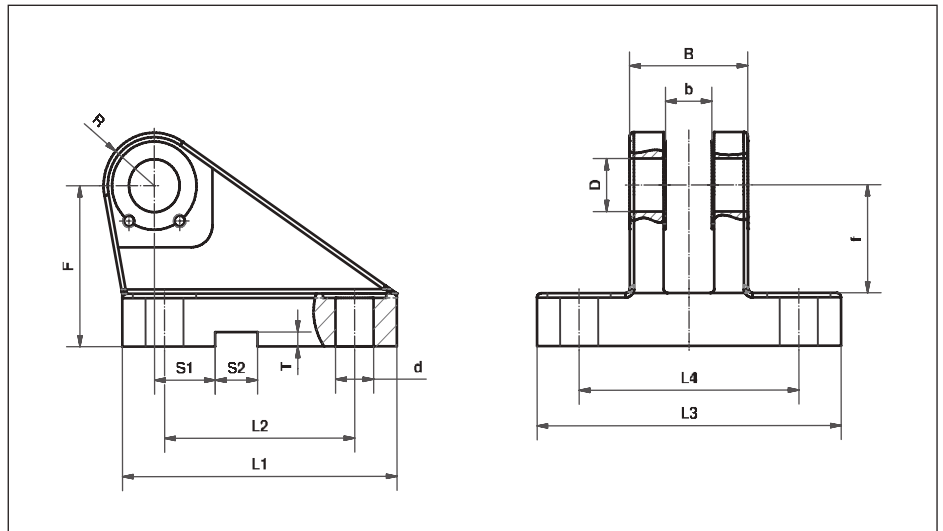

| Size D (K7) | B (h14) | L1 | L2 (js13) | L3 | L4 (js13) | d | R | F (js11) | f | b +0,3/-0,1 | S1 (js14) | S2 (N9) | T (+0,3) | load max. (kN) | Weight g |
|-------------|---------|-----|-----------|-----|-----------|------|-----|----------|-----|-------------|-----------|---------|----------|----------------|----------|
| 12 | 30 | 60 | 40 | 75 | 55 | 9,0 | 12 | 40 | 29 | 10 | 16 | 10 | 3,3 | 8,0 | 520 |
| 16 | 40 | 80 | 55 | 95 | 70 | 11,0 | 16 | 50 | 37 | 14 | 18 | 16 | 4,3 | 12,5 | 1050 |
| 20 | 50 | 90 | 58 | 120 | 85 | 13,5 | 20 | 55 | 39 | 16 | 20 | 16 | 4,3 | 20,0 | 1720 |
| 25 | 60 | 110 | 70 | 140 | 100 | 15,5 | 25 | 65 | 48 | 20 | 22 | 25 | 5,4 | 32,0 | 2720 |
| 30 | 70 | 135 | 90 | 160 | 115 | 17,5 | 30 | 85 | 62 | 22 | 24 | 25 | 5,4 | 50,0 | 5150 |
| 40 | 80 | 170 | 120 | 190 | 135 | 22,0 | 40 | 100 | 72 | 28 | 24 | 36 | 8,4 | 80,0 | 9300 |
| 50 | 100 | 215 | 145 | 240 | 170 | 30,0 | 50 | 125 | 90 | 35 | 35 | 36 | 8,4 | 125,0 | 18300 |
| 60 | 120 | 260 | 185 | 270 | 200 | 39,0 | 60 | 150 | 108 | 44 | 35 | 50 | 11,4 | 200,0 | 35000 |
| 80 | 160 | 340 | 260 | 320 | 240 | 45,0 | 80 | 190 | 140 | 55 | 35 | 50 | 11,4 | 320,0 | 63000 |
| 100 | 200 | 400 | 300 | 400 | 300 | 48,0 | 100 | 210 | 150 | 70 | 35 | 63 | 12,4 | 500,0 | 109000 |

Materials:

Housing: spheroidal graphite cast iron EN-GJS 500/7

Bearing block for hydraulic cylinders - bolt

Series KPA../KPB..

Connecting bolt

for DK

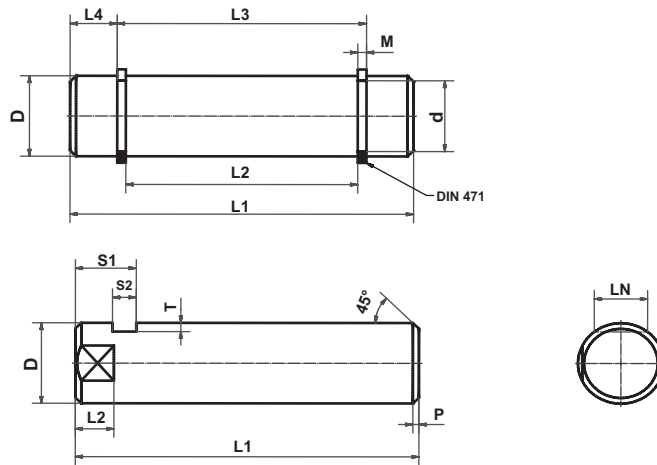

KPA:

| Size D (h6) | d | L1 | L2 | L3 +0,1 | L4 | M (H13) | Circlip | Weight g |
|-------------|-----|-----|-----|---------|-----|---------|---------|----------|
| 12 | 12 | 35 | 30 | 33,0 | 1,0 | 1,10 | 12x1 | 30 |
| 16 | 16 | 46 | 40 | 43,0 | 1,5 | 1,10 | 16x1 | 80 |
| 20 | 20 | 57 | 50 | 53,4 | 1,8 | 1,30 | 20x1,2 | 140 |
| 25 | 25 | 67 | 60 | 63,4 | 1,8 | 1,30 | 25x1,2 | 260 |
| 30 | 30 | 79 | 70 | 74,0 | 2,5 | 1,60 | 30x1,5 | 440 |
| 40 | 40 | 93 | 80 | 84,5 | 4,2 | 1,85 | 40x1,75 | 900 |
| 50 | 50 | 115 | 100 | 105,0 | 5,0 | 2,15 | 50x2 | 1700 |
| 60 | 60 | 135 | 120 | 125,0 | 5,0 | 2,15 | 60x2 | 3100 |
| 80 | 80 | 178 | 160 | 166,0 | 6,0 | 2,65 | 80x2,5 | 7100 |
| 100 | 100 | 221 | 200 | 207,0 | 7,0 | 3,15 | 100x3 | 14400 |

KPB:

| Size D (h6) | L1 | L2 | S1 | S2 | T | P | LN | Weight g |
|-------------|-----|------|----|------|----|-----|----|----------|
| 12 | 40 | 4,5 | 8 | 3,3 | 4 | 1,0 | 10 | 40 |
| 16 | 50 | 5,5 | 8 | 3,3 | 4 | 1,0 | 13 | 80 |
| 20 | 62 | 5,5 | 10 | 4,5 | 5 | 1,5 | 17 | 150 |
| 25 | 72 | 5,5 | 10 | 4,5 | 5 | 1,5 | 22 | 270 |
| 30 | 85 | 7,5 | 13 | 5,5 | 6 | 2,0 | 24 | 410 |
| 40 | 100 | 9,5 | 16 | 6,5 | 7 | 2,0 | 32 | 910 |
| 50 | 122 | 10,0 | 19 | 9,0 | 8 | 2,0 | 41 | 1710 |
| 60 | 145 | 11,0 | 20 | 9,0 | 9 | 2,0 | 50 | 3130 |
| 80 | 190 | 15,0 | 26 | 11,0 | 11 | 3,0 | 70 | 7140 |
| 100 | 235 | 15,0 | 30 | 13,0 | 14 | 3,0 | 90 | 1440 |

Materials:

Bolt: alloyed case-hardened steel 20MnCr5

Bearing block for hydraulic cylinders - bolt

Series

KPE../KPC../KPD..

Connecting bolt

KPE for version
IKA../IKB..

KPC and KPD for version
IKA../IKB../IF.. with funnel
type lubrication nipple

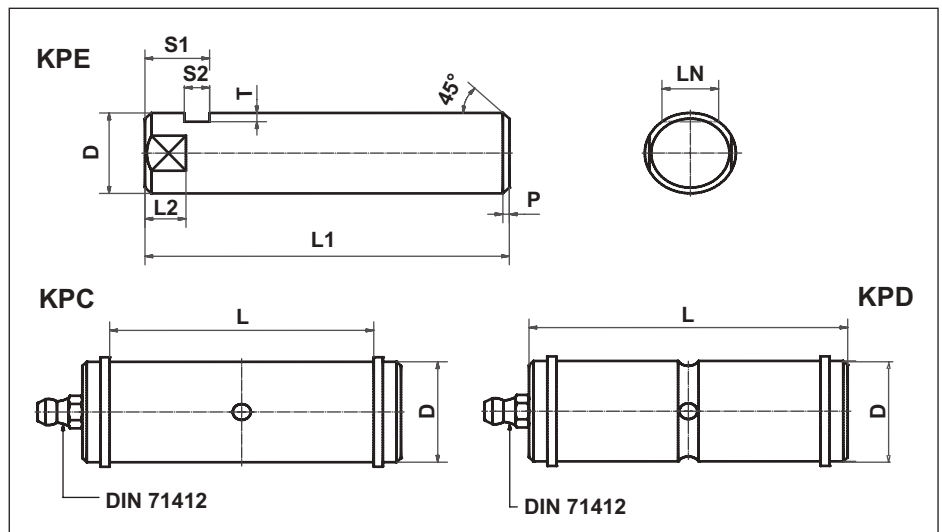

KPE:

| Size D (m6) | L1 | L2 | S1 | S2 | T | P | LN | Weight g |
|-------------|-----|------|----|------|----|-----|----|----------|
| 10 | 34 | 4,5 | 8 | 3,3 | 3 | 1,0 | 8 | 21 |
| 12 | 38 | 4,5 | 8 | 3,3 | 4 | 1,0 | 10 | 33 |
| 16 | 46 | 5,5 | 8 | 3,3 | 4 | 1,0 | 13 | 70 |
| 20 | 58 | 5,5 | 10 | 4,5 | 5 | 1,5 | 17 | 140 |
| 25 | 69 | 6,5 | 10 | 4,5 | 5 | 1,5 | 21 | 270 |
| 32 | 87 | 8,5 | 13 | 5,5 | 6 | 2,0 | 27 | 450 |
| 40 | 110 | 8,5 | 16 | 6,5 | 7 | 2,0 | 32 | 910 |
| 50 | 133 | 8,5 | 19 | 9,0 | 8 | 2,0 | 41 | 1710 |
| 63 | 164 | 8,5 | 20 | 9,0 | 9 | 2,0 | 55 | 3130 |
| 80 | 202 | 11,5 | 26 | 11,0 | 11 | 3,0 | 65 | 7140 |
| 100 | 246 | 15,0 | 28 | 13,0 | 14 | 3,0 | 90 | 15000 |

KPC/KPD:

| Size D (f8/m6) | L (H16) | load max. (kN) | Weight g |
|----------------|---------|----------------|----------|
| 10 | 25 | 5,0 | 10 |
| 12 | 29 | 8,0 | 30 |
| 16 | 37 | 12,5 | 60 |
| 20 | 46 | 20,0 | 130 |
| 25 | 57 | 32,0 | 250 |
| 32 | 72 | 50,0 | 500 |
| 40 | 92 | 80,0 | 1000 |
| 50 | 112 | 125,0 | 1900 |
| 63 | 142 | 200,0 | 3800 |
| 80 | 172 | 320,0 | 7600 |

Materials:

Bolt: alloyed case-hardened steel 20MnCr5

Information: for KPC the tolerance m6 for D and for KPD the tolerance f8 for D

Bearing block for hydraulic cylinders - fixing plate

Series PPP...

Fixing plate

Version for KPB../KPE..

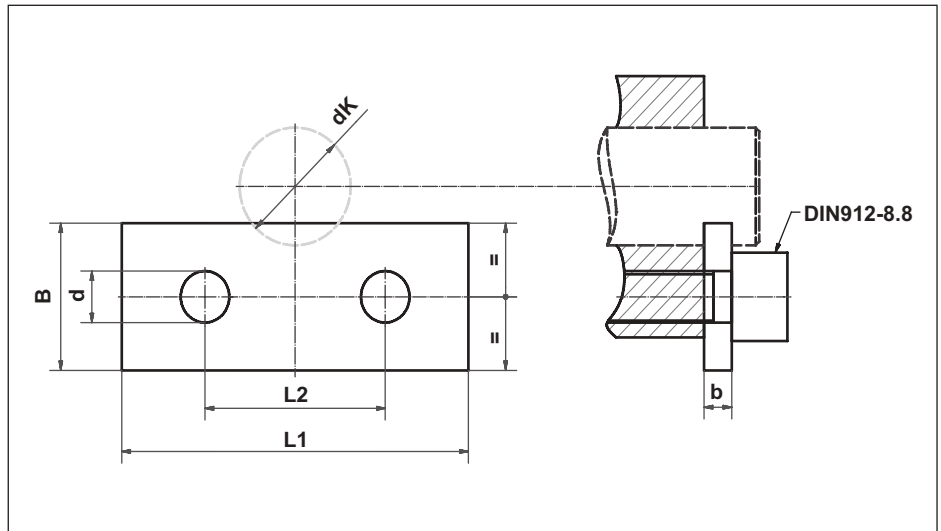

| Size | L1 | L2 | B | d | dK | b | Threaded bore | Circlip | Weight g |
|------|-----|----|----|------|-------|----|---------------|---------|----------|
| 10 | 20 | 11 | 15 | 5,4 | 10/12 | 3 | M5x12 | 5 | 20 |
| 12 | 27 | 16 | 15 | 6,4 | 12 | 3 | M6x12 | 6 | 20 |
| 16 | 40 | 25 | 15 | 6,4 | 16 | 3 | M6x12 | 6 | 30 |
| 20 | 40 | 25 | 18 | 6,4 | 20 | 4 | M6x16 | 6 | 40 |
| 25 | 40 | 25 | 18 | 6,4 | 25 | 4 | M6x16 | 6 | 40 |
| 30 | 45 | 30 | 20 | 6,4 | 30 | 5 | M6x16 | 6 | 40 |
| 40 | 62 | 42 | 20 | 8,4 | 40 | 6 | M8x20 | 8 | 80 |
| 50 | 65 | 45 | 25 | 8,4 | 50 | 8 | M8x20 | 8 | 90 |
| 60 | 80 | 55 | 25 | 10,5 | 60 | 8 | M10x25 | 10 | 170 |
| 80 | 90 | 60 | 30 | 10,5 | 80 | 10 | M10x25 | 10 | 250 |
| 100 | 120 | 90 | 40 | 10,5 | 100 | 12 | M10x25 | 10 | 490 |

Materials:

Plate: unalloyed structural steel S355JR (St52-3)

Bearing block for hydraulic cylinders - fork head

Series IF..

Fork head

to ISO 8132

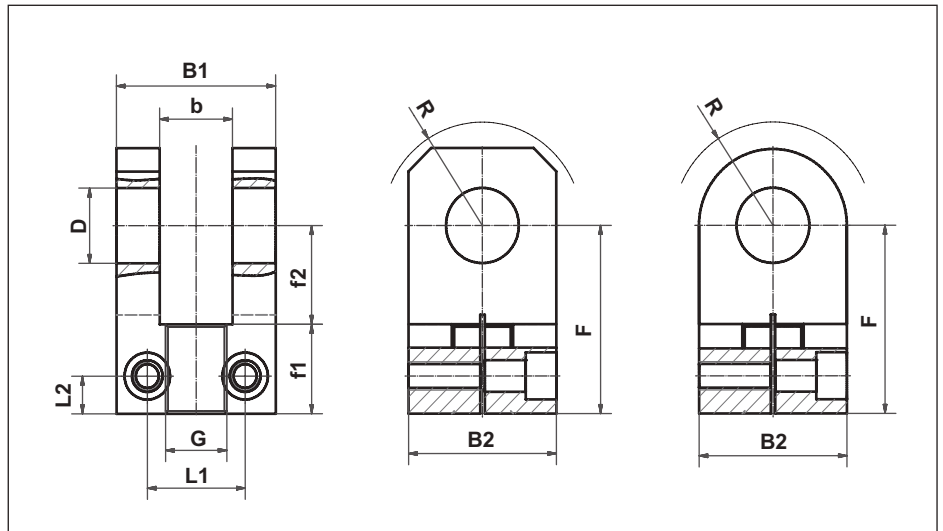

| Size D (H9) | B1 (h16) | B2 | b (A13) | F (js13) | f1 | f2 min. | L1 | L2 | G (6H) | R max. | nominal force (kN) | screw DIN 912 | Weight g |
|-------------|----------|-----|---------|----------|----|---------|-----|----|----------|--------|--------------------|---------------|----------|
| 10 | 24 | 20 | 10 | 37 | 19 | 18 | 16 | 7 | M10x1,25 | 11 | 5,0 | M3x12 | 100 |
| 12 | 28 | 25 | 12 | 38 | 20 | 18 | 18 | 7 | M12x1,25 | 16 | 8,0 | M4x16 | 160 |
| 16 | 36 | 30 | 16 | 44 | 22 | 22 | 24 | 8 | M14x1,5 | 20 | 12,5 | M6x20 | 270 |
| 20 | 45 | 40 | 20 | 52 | 25 | 27 | 28 | 9 | M16x1,5 | 25 | 20,0 | M8x30 | 530 |
| 25 | 56 | 50 | 25 | 65 | 31 | 34 | 35 | 11 | M20x1,5 | 32 | 32,0 | M10x35 | 1120 |
| 32 | 70 | 60 | 32 | 80 | 38 | 41 | 45 | 12 | M27x2 | 40 | 50,0 | M12x45 | 2180 |
| 40 | 90 | 80 | 40 | 97 | 45 | 52 | 60 | 16 | M33x2 | 50 | 80,0 | M16x60 | 4400 |
| 50 | 110 | 100 | 50 | 120 | 56 | 64 | 73 | 19 | M42x2 | 63 | 125,0 | M20x70 | 7600 |
| 63 | 140 | 120 | 63 | 140 | 65 | 75 | 93 | 25 | M48x2 | 71 | 200,0 | M24x90 | 17700 |
| 80 | 170 | 150 | 80 | 180 | 86 | 94 | 118 | 30 | M64x3 | 90 | 320,0 | M30x100 | 30600 |

Materials:

Bolt: unalloyed structural steel S355JR (St52-3)

Bearing block for hydraulic cylinders - connecting pins

Series PB..

Connecting pin

for version IS../ISS..

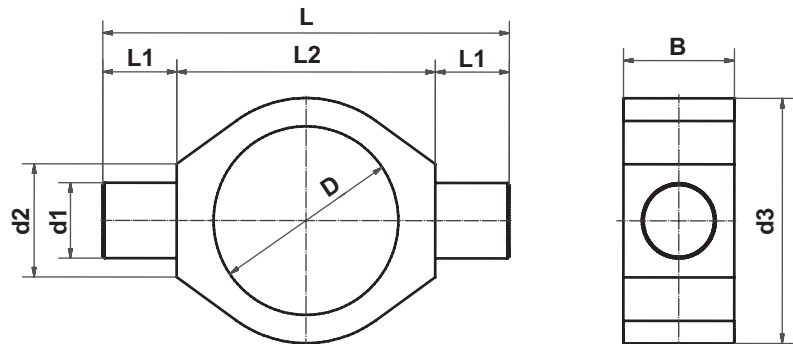

| Size D (Ø) | d1 (Ø) | d2 | d3 (Ø) | B | L | L1 | L2 | Weight g |
|------------|--------|----|--------|----|-----|----|-----|----------|
| 50 | 20 | 30 | 65 | 30 | 110 | 20 | 70 | 520 |
| 60 | 25 | 35 | 75 | 35 | 130 | 25 | 80 | 790 |
| 70 | 30 | 45 | 90 | 45 | 160 | 30 | 100 | 1570 |
| 80 | 35 | 50 | 100 | 50 | 180 | 35 | 110 | 2030 |
| 92 | 40 | 55 | 115 | 55 | 195 | 40 | 115 | 2600 |
| 95 | 40 | 55 | 115 | 55 | 195 | 40 | 115 | 2400 |
| 105 | 45 | 60 | 125 | 60 | 215 | 45 | 125 | 3000 |
| 115 | 50 | 70 | 145 | 70 | 245 | 50 | 145 | 5300 |
| 140 | 60 | 80 | 170 | 80 | 290 | 60 | 170 | 7700 |

Materials:

Connecting pin: unalloyed structural steel S355JR (St52-3)

Bearing block for hydraulic cylinders - bracket

Series IS../ISS ..

Bracket with with funnel
type lubrication nipple

to ISO 8132

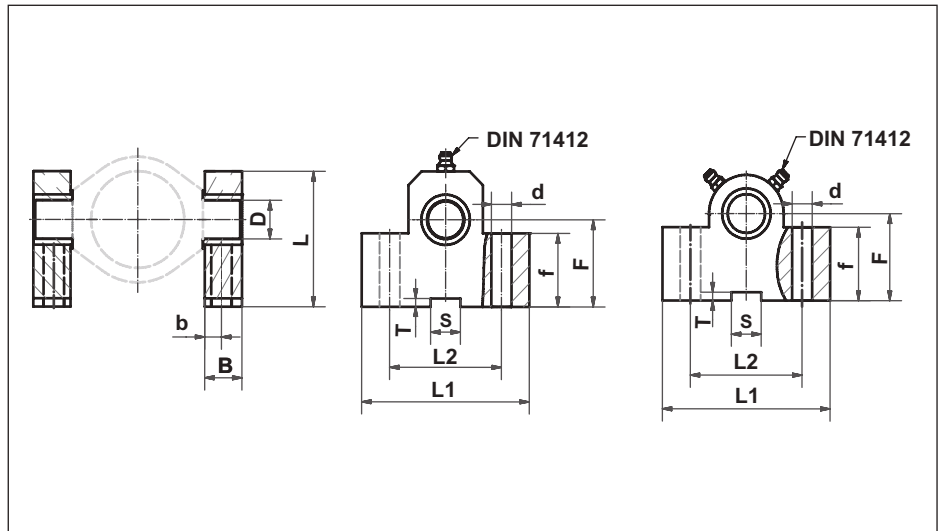

IS:

| Size D (H7) | F (JS12) | f | L | L1 | L2 (js13) | B | b (js13) | S (N9) | T +0,3 | d (H13) | nominal force (kN) | Weight g |
|-------------|----------|-----|-----|-----|-----------|-----|----------|--------|--------|---------|--------------------|----------|
| 12 | 34 | 25 | 49 | 63 | 40 | 17 | 8 | 10 | 3,3 | 9,0 | 8,0 | 430 |
| 16 | 40 | 30 | 59 | 80 | 50 | 21 | 10 | 16 | 4,3 | 11,0 | 12,5 | 930 |
| 20 | 45 | 38 | 69 | 90 | 60 | 21 | 10 | 16 | 4,3 | 11,0 | 20,0 | 1210 |
| 25 | 55 | 45 | 80 | 110 | 80 | 26 | 12 | 25 | 5,4 | 13,5 | 32,0 | 2100 |
| 32 | 65 | 52 | 100 | 150 | 110 | 33 | 15 | 25 | 5,4 | 17,5 | 50,0 | 4120 |
| 40 | 76 | 60 | 120 | 170 | 125 | 41 | 16 | 36 | 8,4 | 22,0 | 80,0 | 7450 |
| 50 | 95 | 75 | 140 | 210 | 160 | 51 | 20 | 36 | 8,4 | 26,0 | 125,0 | 13660 |
| 63 | 112 | 85 | 177 | 265 | 200 | 61 | 25 | 50 | 11,4 | 33,0 | 200,0 | 25000 |
| 80 | 140 | 112 | 220 | 325 | 250 | 81 | 31 | 50 | 11,4 | 39,0 | 320,0 | 54000 |
| 100 | 180 | 152 | 280 | 385 | 295 | 102 | 45 | 63 | 12,4 | 52,0 | 500,0 | 100000 |

ISS:

| Size D (H7) | F (JS12) | f | L | L1 | L2 (js13) | B | b (js13) | S (N9) | T +0,3 | d (H13) | nominal force (kN) | Weight g |
|-------------|----------|-----|-----|-----|-----------|-----|----------|--------|--------|---------|--------------------|----------|
| 12 | 38 | 25 | 55 | 63 | 40 | 17 | 8 | 10 | 3,3 | 9 | 8,0 | 450 |
| 16 | 45 | 30 | 65 | 80 | 50 | 21 | 10 | 16 | 4,3 | 11 | 12,5 | 900 |
| 20 | 55 | 38 | 80 | 90 | 60 | 21 | 10 | 16 | 4,3 | 11 | 20,0 | 1340 |
| 25 | 65 | 45 | 90 | 110 | 80 | 26 | 12 | 25 | 5,4 | 14 | 32,0 | 2320 |
| 32 | 75 | 52 | 110 | 150 | 110 | 33 | 15 | 25 | 5,4 | 18 | 50,0 | 4470 |
| 40 | 95 | 60 | 140 | 170 | 125 | 41 | 16 | 36 | 8,4 | 22 | 80,0 | 8000 |
| 50 | 105 | 72 | 150 | 210 | 160 | 51 | 20 | 36 | 8,4 | 26 | 125,0 | 13500 |
| 63 | 125 | 87 | 195 | 265 | 200 | 61 | 25 | 50 | 11,4 | 33 | 200,0 | 27430 |
| 80 | 150 | 112 | 230 | 325 | 250 | 81 | 31 | 50 | 11,4 | 39 | 320,0 | 54000 |
| 100 | 200 | 150 | 300 | 410 | 320 | 101 | 42 | 63 | 12,4 | 52 | 500,0 | 112000 |

Materials:

Bracket: unalloyed structural steel S355JR (St52-3)

Höhn Precision Parts - this name represents quality production. Forty years of experience guarantee the companies reliable capability. The continuously modernized machine park enables a flexible and economic production of turned and machined parts.

Variety for Höhn does mean that besides the turning, machining and grinding of parts, also complete components and assemblies are manufactured.

In agreement with the TÜV Southwest, Höhn received stamp authorization for continued re-stamping of material specification 3.1.B. since 1981. Höhn achieved also the

DIN EN ISO 9001:2000 certification.

5-axial
symmetric machining
(3-D measuring machine)

Höhn processes all sorts of steel e.g.: Titan, Hasteloy, 17-4Ph, non-iron and non-ferrous heavy metal. Though constant stock of stainless steel material such as 1.4104, Aisi 430F, 1.4301, Aisi 304, 1.4305, Aisi 303, 1.4571, Aisi 316Ti, 1.4541, Aisi 321 a prompt delivery response is guaranteed.



This connecting rod with bearing for carriages shows a constructive solution through the close cooperation between **Höhn** and **FLURO®**.

Production of all sorts of shafts, \varnothing 20 to \varnothing 120 x 1000 mm length. Surface finish according to customer requirements.

Machining of the rod from \varnothing 10 to \varnothing 80 mm, chucking parts from \varnothing 10 to \varnothing 300 mm.

Company: _____ Contact: _____ Phone: _____

Center Distance = _____ mm

Thickness $t =$ _____ mm (observe Spherical width!)
 Material: _____ with 2x Sphericals: _____

Please indicate: Form A Form B

Center Distance = _____ mm Adjustable Range = +/- _____ mm

Ridge to identify left hand thread
 Left hand thread
 Hexagon SW = _____ alternative: Pipe \varnothing _____ with cross bore
 Length = _____ mm Material: _____
 Lock Nut DIN 439 (flat) Material: _____
 Rod End _____

Center Distance = _____ mm Adjustable Range = +/- _____ mm

Left hand thread
 Threaded Rod Length = _____ mm Material: _____
 Lock Nut DIN 439 (flat) Material: _____
 Rod End _____

with incorporated Spherical Type: _____
 Head Width $M =$ _____ mm, Ball Width $B =$ _____ mm
 Thread Length $GL =$ _____ mm, Thread $G =$ _____

Material Ball: _____
 Material Outer Ring: _____
 Maintenance free: Yes No

Custom-Made Products



Rosenfeld is situated between the city of Stuttgart and the lake Bodensee, in southern Germany. You can get to us easily from the international airport of Stuttgart by car. Drive Highway A81 south (towards Singen), exit at Oberndorf and follow the road to Rosenfeld. Our company's plant is situated in the midst of an industrial area on the right hand side behind the town's entrance. We invite you to pay a visit at our manufacturing plant to see our capability.

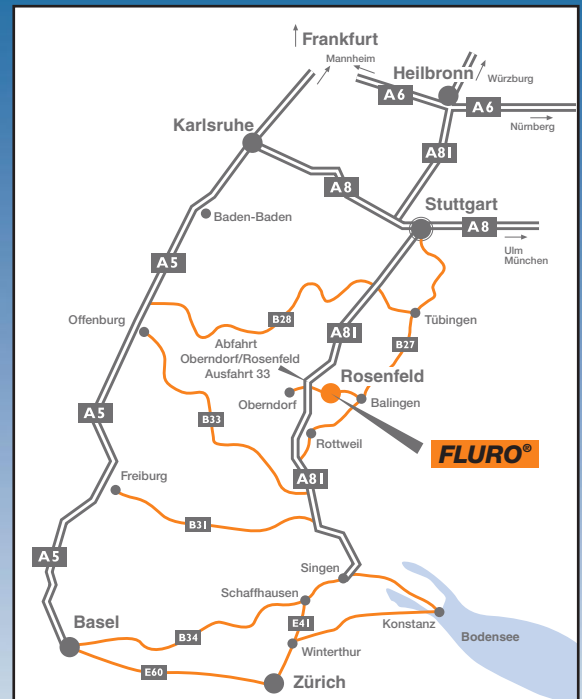

This is how you can get to us.



Siemensstrasse 13
D-72348 Rosenfeld / Germany
Phone +49 (0) 74 28 93 85-0
Fax +49 (0) 74 28 93 85-25
www.fluro.de
E-Mail: info@fluro.de

FLURO®-Gelenklager GmbH